



GULF CRETE LTD.

شركة خليج الخرسانه المحدوده

Company Profile

CONSTRUCTION MAINTENANCE REPAIR & RESTORATION

Gulf Crete Contracting LTD.



SCAN ME



 Gulfcrete.com

Agenda

4-5	Introduction	23-25	Capital Equipment
6	Mission & Vision	26-28	Work Target Areas
7-17	Our Services	29-34	Activities
18-19	Organization Chart	35-101	Work Images
20-22	Human Recourses	102-104	Partner

Agenda

105-119	Major Projects
120-122	Approval
123-133	GOVERNMENT CERTIFICATION
134-142	Accreditation Certification
143-210	Work Certification

211-216	Training Certification
217-241	CO-MENDER & GULFCRETE
242	Contact us
243	Conclusion



INTRODUCTION





Gulf Crete

- ▶ Gulf Crete Contracting LTD. Is a specialized contracting company that comprises shareholders with a combined experience of 30 years in the Construction industry. Its main principal owner is a 2nd Classification Contractor that has been in business since 1979 in the Saudi Arabian Market for Civil, Electromechanical & Architectural works. In 2008 the General Contracting Company saw the need for a specialized division focusing on Fire Proofing, Water Proofing, Concrete Repair & Restoration, Specialty Floor Coatings, and Maintenance Repair & Operations. This division flourished with success and in 2014 it was unanimously decided by all shareholders to separate the division as its own stand-alone entity.

Mission

To deliver a premier company in the Jordanian Market delivering innovative services, out-of-the-box thinking, and advanced technologies based on an in-depth understanding & market analysis in the field of fireproofing, water proofing, concrete repair & restoration, specialty flooring & MRO. Gerziem Management is dedicated to being a company admired for its excellence in providing creative approaches, superior advice, and executions capabilities by its clients, shareholders, suppliers, and employees

Vision

To become the market leader in our industry by utilizing innovation, technology, state of the art equipment & materials and key human resource elements while delivering top class quality service while being conscious of the clients bottom line needs in the Jordanian Market

Core Value

Our Core values will shape the culture and define the character of our company, guiding how we behave and make decisions. Put our client's interest ahead of our own: This means we deliver more than is expected. It doesn't simply mean we do whatever the client asks Integrity: Exciting trust by taking accountability, acting ethically and promoting open forms of communication between all individuals at all levels Best people: Attracting, training, and developing the best talent in our industry and encouraging a "can do" attitude. Client Value Creation: Improving our client's business through performance, long-term win-win scenarios and focusing on execution excellence

The background of the entire image is a composite. The top half shows the back of a person wearing a white long-sleeved shirt and a high-visibility safety vest with yellow and red reflective stripes. The bottom half shows a hand holding a rolled-up white blueprint. The background is a high-angle, wide shot of a dense cityscape with many skyscrapers and buildings under a clear sky.

OUR SERVICES

Our Services



Concrete Repair/Restoration &
Strengthening

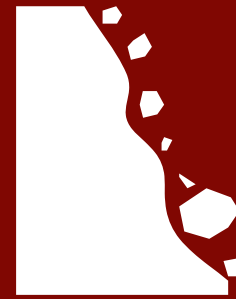

Rock Fall Protection

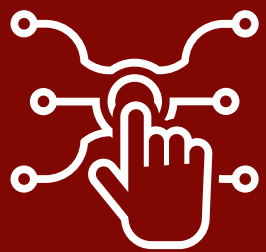

Survey Technology

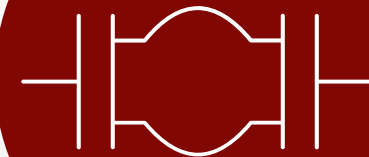

Expansion joint

Our Services



Fire Proofing

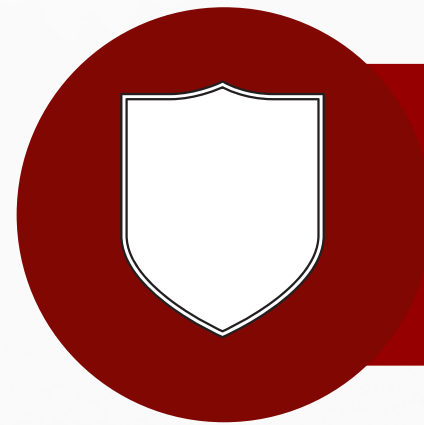

Vertical & Horizontal Protective and
Decorative Coatings

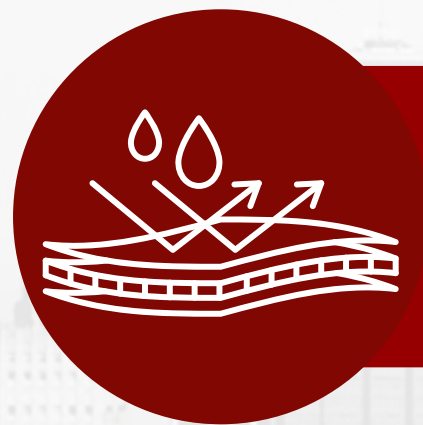

Water Proofing



Renovation & Fit Out



Concrete Repair/Restoration & Strengthening

A leader in its field - GCL offers comprehensive engineering solutions, technical assistance, and quality applications for concrete repair, flooring repairs, and structural concrete. In addition, GCL provides the design and implementation of structural strengthening systems using Fiber Reinforced Polymer (FRP). Our experience and expertise combine specialized and conventional concrete repair methods to provide the most practical solution for all concrete repair projects.





RockFall Protection

During the last decades, large rock falls occurred on the steep slopes along mountainous areas of Saudi Arabia, causing serious damage to buildings and traffic facilities, injury to people, and delayed traffic on roads. Settlements, and transportation facilities in mountainous areas with steep rock slopes are vulnerable to rock falls. In recent years, a number of highways have been or are scheduled to be built in the southern region of Saudi Arabia, that carry significant risk of increasing rock fall hazard events. GCL offers comprehensive engineering solutions, technical assistance, and quality applications for rockfall protection.



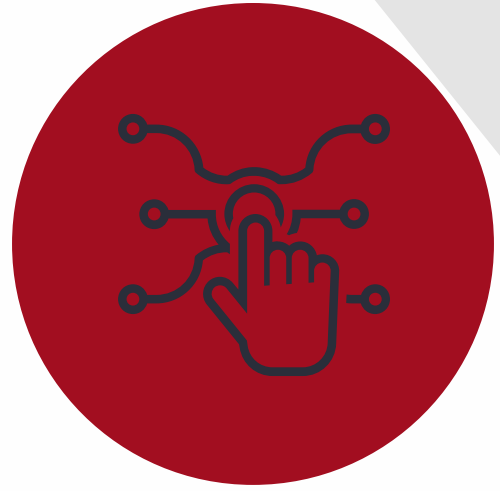

Survey Technology

During the past 50 years, surveying and engineering measurement technology has made five quantum leaps: the electronic distance meter, total station, GPS, robotic total station, and laser scanner. Aircraft systems or drones will be the sixth quantum leap in technology. Surveying with a drone offers enormous potential to GIS professionals. With a drone, it is possible to carry out topographic surveys of the same quality as the highly accurate measurements collected by traditional methods, but in a fraction of the time. This substantially reduces the cost of a site survey and the workload of specialists in the field. GCL Provides all these services.

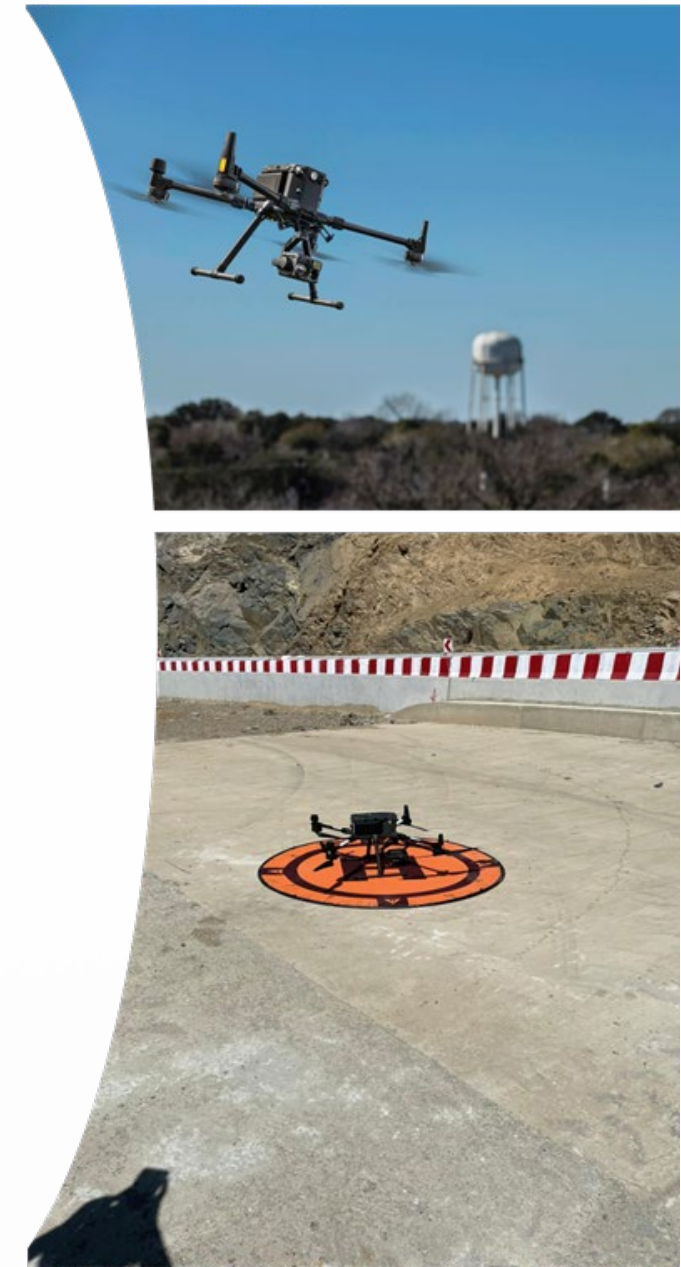

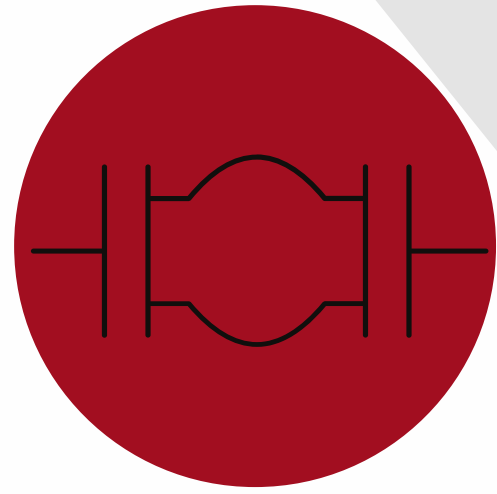

Expansion joint

Expansion joints are designed to allow for continuous traffic between structures while accommodating movement, shrinkage, and temperature variations on reinforced and prestressed concrete, composite, and steel structures. They stop the bridge from bending out of place in extreme conditions and also allow enough vertical movement to permit bearing replacement without the need to dismantle the bridge expansion joint. GCL has expertise and experience in such applications.

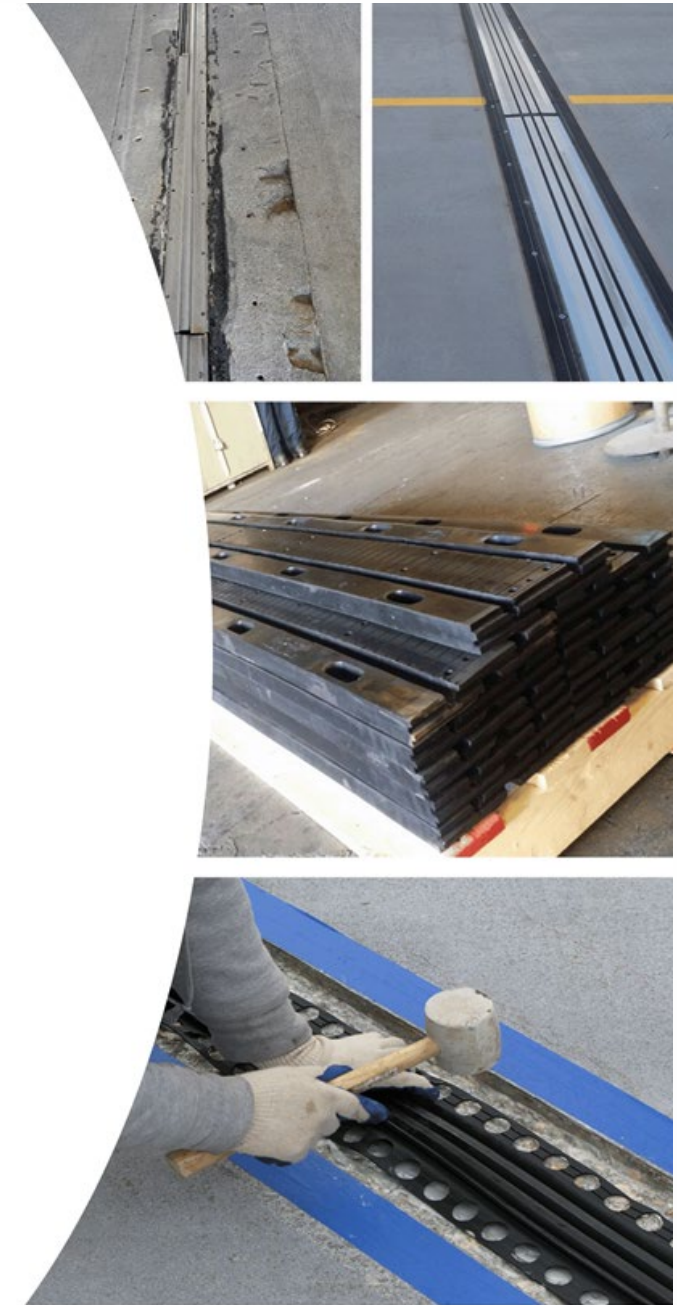



Fire Proofing

GCL specializes in commercial fireproofing, thermal and acoustical insulation, and firestop services. We adhere to industry standards and provide quality services at reasonable prices. We will examine the situation closely whether it's a new install or retrofit remodel project and work together with you to achieve the desired solution. Timelines are crucial in commercial construction, and it is our goal to help keep your projects moving, so constant coordination is very important to us.





Vertical & Horizontal Protective and Decorative Coatings

Protective coatings are given to concrete surfaces to prevent damage and for a rehabilitated look. GCL co. supplies and applies a wide range of protective coatings. Appropriate protective coating materials are recommended by experienced Engineers from GCL Co. to provide quality solutions. Epoxy resins, non-slip coatings, polyurethanes, cementations coatings, acrylic coatings, membranes, food grade systems, tanking/waterproofing, and chemical-resistant coatings. GCL offers decorative flooring solutions that give a new look to an old concrete floor. Decorative coatings are a perfect alternative to concrete replacement, tiles, resin floors, and other topical systems. Decorative floors include acid staining, densifying, impregnated sealers & polished concrete, Creative & flexible designs are created with logos saw cuts, aggregate & decorative saw cuts. Specialty grinding machines can be helpful in a way to provide the required preparation of the concrete substrate for proper levels, mechanical bonding, and decorative work.





Water Proofing

Waterproofing is necessary in any kind of environment, but especially in areas with heavy moisture. In areas where there is a lot of moisture collection on the ground, hydrostatic pressure can create a nightmare for a building's foundation. Whether it's waterproofing or damp proofing, our experts here at GCL know the jeopardy that inferior waterproofing puts a structure in, and they strive to mitigate any issues with superior knowledge and experience. We carefully select premium quality products to best match the requirements and our installers are highly trained and qualified.

- ✓ Waterproofing
- ✓ Dampproofing
- ✓ Site Caulking
- ✓ Tilt Wall Panel

- ✓ Caulking Water Repellants
- ✓ Below Grade
- ✓ Waterproofing Deck Coatings

- ✓ Window Caulking
- ✓ Floor Sealers
- ✓ Traffic Coatings





Renovation & Fit Out

GCL carries out exceptional commercial and residential property refurbishments and renovations. we fit out precision interiors; we develop client relationships based on mutual trust and understanding and are open to our client's objectives. With our vast global relationship with material suppliers of paints, wood, doors, furniture & fixtures. GCL can provide you with a total turnkey solution. Whether it's a listed building renovation, retail fit-out, or office fit-out, we apply our stringent management control procedures to guarantee the highest standard of finish and defect-free handover, irrespective of the demands of the contract programmed. We are solid and reliable, and we exceed client expectations.

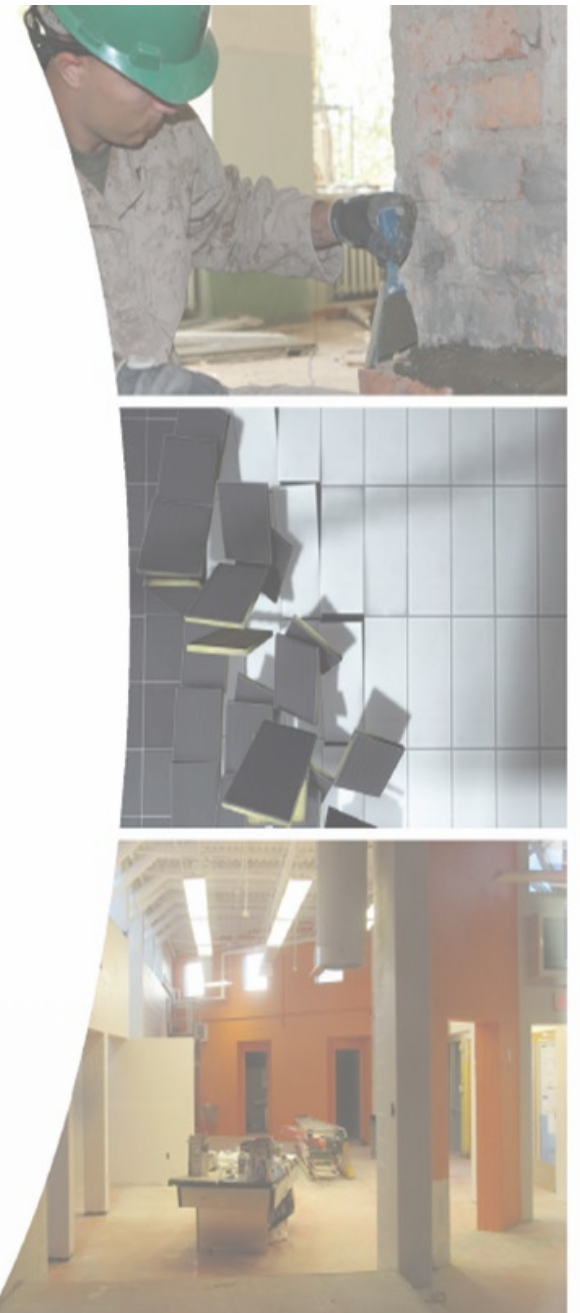



ORGANIZATION CHART



Organization Chart

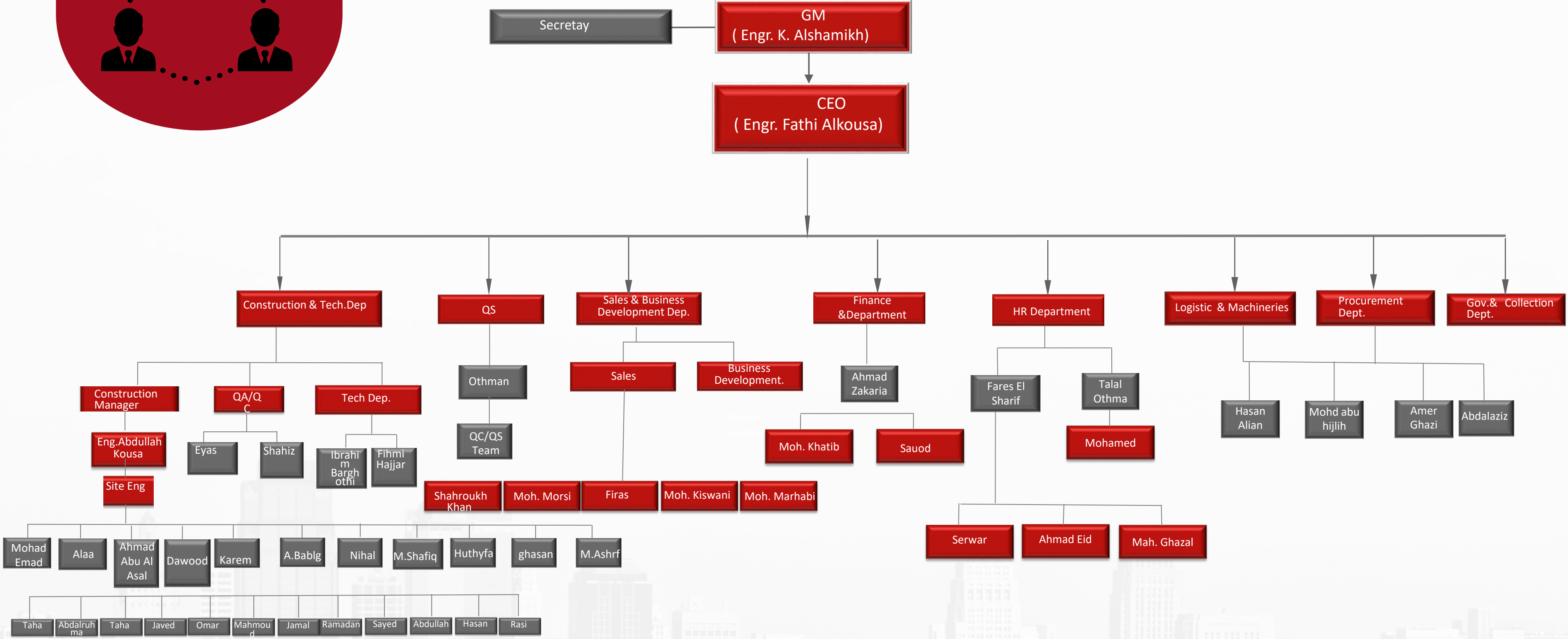
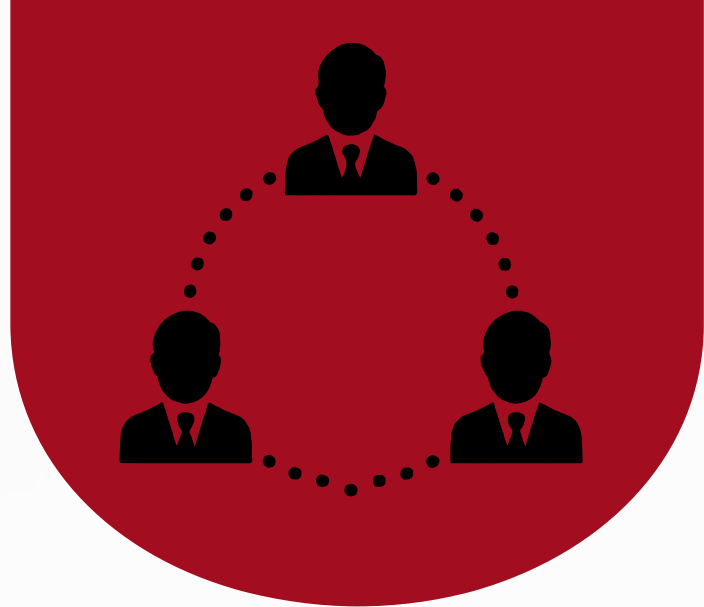



HUMAN RESOURCES



Our Human Resources

GCL classifies all its employees as Team members as they are all contributing to the process of producing goods or providing services. All the engineering staff, technicians, and team members are trained, and educated in new processes, materials, safety procedures, and tools, which helps in maintaining the highest level of quality, the company has >100 skilled and unskilled team members in addition to the engineering and foreman whom are experts in their field with high efficiency.

Our Human Resources



Position	Nationality	Number of Staff
Civil& Arch Eng	Arab	10
Civil Eng Asst	East Asian& Syrian	5
Quantity Surveyor	East Asian & Filipino	2
Finance, HR, Procurement & Administration	Arab and East Asian	5
Sales	Arab and East Asian	5
Safety Officer	East Asian & Pakistani	2
Drafts Man	Filipino	2
Carpenters	East Asian, Syrian & Pakistani (COP.)	25
Steel Workers	East Asian & Syrian (COP.)	32
Skilled Workers (Painters, Roofers, etc.)	All Nationality	150
Total		238



CAPITAL EQUIPMENT



Our Capital Equipment



Total Equipment more than
180 machines and tool.



Our Capital Equipment

GCL owns the following equipment stocked at our local facilities:

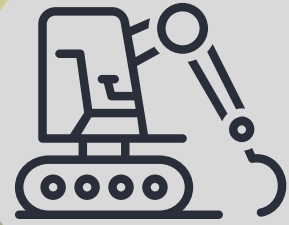

EQUIPMENT DESCRIPTION	Unit	QTY	EQUIPMENT DESCRIPTION	Unit	QTY	EQUIPMENT DESCRIPTION	Unit	QTY
Air Compressor 125cfm	Pcs	1	Generator 100kw	Pcs	1	Tile Grinding	Pcs	2
Air Compressor 250cfm	Pcs	1	Generator 250Kw	Pcs	1	DRONE & Surveying Instrument	Pcs	3
Air Compressor 375cfm	Pcs	1	Air Less Spray Machines	Pcs	10	Water Tankers	Pcs	2
Diamond Grinding MGM 500	Pcs	5	Foam Concrete Pumping machine	Pcs	3	Pick-up	Pcs	3
Diamond Grinding MGM 1000	Pcs	16	Asphalt cutter	Pcs	3	Diana	Pcs	1
Diamond Grinding MGM Grand 3 headed	Pcs	4	Water pumps	Pcs	2	Lesiter Hand Welding Machine	Pcs	12
Airless Spray Machine for Fireproof And Epoxy Application	Pcs	5	Concrete mixer	Pcs	2	Lesiter Automatic Welding Machine	Pcs	2
Screed Pumping machine	Pcs	2	Small Jack Hammers	Pcs	40	Postemizer Grout Injection Machine	Pcs	4
Epoxy Injection machine	Pcs	3	Big Jack Hammers	Pcs	20	Postemizer Cementitious Fire Proof Machine	Pcs	3
Delta Shot Crete machine	Pcs	2	Concrete Drilling Machine	Pcs	10	ShotCrete Machine Betonmaster (Turbosol+putzmeister +otherbrands)	Pcs	5
Customizer fireproofing	Pcs	2	Concrete Saw	Pcs	2	Robotic Shotcrete machine	Pcs	1
Generator 10kw	Pcs	1	Air Blower	Pcs	30	Anchorbolts & Rock Bolts nailing Drilling Machine	Pcs	5



WORK TARGET AREAS & MARKET POSITION

Work Target Area



MAIN CONTRACTORS PROJECT

Initial condition surveys, concrete & steel repairs, Waterproofing & roofing works, joint sealants, specialist coatings.

BUILDINGS

Initial condition surveys, concrete & steel repairs, Waterproofing & roofing works, joint sealants, specialist coatings.

CONCRETE REPAIR

Leaking, repairing damaged concrete, strengthening, and restoration.

Work Target Area



WATER INDUSTRY STRUCTURES

Renovation services, condition surveys, tank linings, leak sealing, reservoir roof lining, concrete repairs, and protective coating.

ROADS AND BRIDGES

Survey, repair, restoration, and strengthening of concrete, steel, and cast-iron structures, new bearing replacements, expansion jointing, and post-tensioning and advising to ensure that work is carried out correctly and safely.

GOVERNMENT INDUSTRY STRUCTURES

Renovation services, condition surveys, tank linings, leak sealing, reservoir roof lining, concrete repairs, and protective coating.



Activities



Structural Activities



- ✓ Structural and Cosmetic Repair System
- ✓ Design and Implementation of Structural
- ✓ Strengthening and Conventional System
- ✓ Concrete Injection System
- ✓ Water Tanks Treatment and Repairs.
- ✓ Repair and protection of Retaining Walls and Bridges.
- ✓ Carbon Fiber Strengthen (CFRP)
- ✓ Reinforced Shot Creating for Earth collapse
- ✓ Cathodic Protection
- ✓ Form & Pump Repair System
- ✓ Anchoring
- ✓ Micro Piles
- ✓ Soil Stabilization
- ✓ Soil Stabilization
- ✓ Soil Injection Reinforced
- ✓ Concrete jacketing

Rock Fall Protection

Survey Technology

- ✓ Rock Bolts Anchorage
- ✓ Sup - Horizontal Drain
- ✓ Shotcrete Application
- ✓ Dynamic Rock Fall Barriers
- ✓ Wire Mesh Ring Netting



- ✓ The electronic distance meter
- ✓ Total station
- ✓ GPS
- ✓ Robotic total station
- ✓ Laser scanner
- ✓ Aircraft systems or drones

Industrial Flooring

Coating Activities

- ✓ Floor Epoxy Resin Coating
- ✓ Floor Traffic Deck Coating
- ✓ Epoxy Self Leveling specially for SCECO buildings
- ✓ Cementitious material Coating. Expansion and Construction Joints Treatment.
- ✓ Bridge Painting
- ✓ Epoxy screed repair



- ✓ Polyurethane Screed (such as U-Crete)
- ✓ Cementitious self leveling Anti- Static Flooring
- ✓ Any other industrial Flooring Micro topping Flooring Coating
- ✓ Heavy Grinding for Floor Concrete Epoxy Terra zzo Finishing

Water Proofing



- ✓ Foam Concrete Work
- ✓ Bituminate Water Proofing Membrane (APP & SBS)
- ✓ PVC Water Proofing Membrane
- ✓ EPDM Water Proofing membrane
- ✓ HDPE Water proofing membrane
- ✓ TPO Water proofing Membrane
- ✓ Compartment Water proofing System
- ✓ Water Tanks Lining System
- ✓ Epoxy Coating
- ✓ Cementitious Coating
- ✓ Crystalline Coating
- ✓ Polysulfide Coating
- ✓ Polyurethane coating
- ✓ Steel Tanks Epoxy & Polyurethane Coating

Miscellaneous Fields

Fire Proofing



Chemical Treatment of Concrete Structures



Airport runways and helipads



Screed Casting , Fit Out Work And Building Renovation

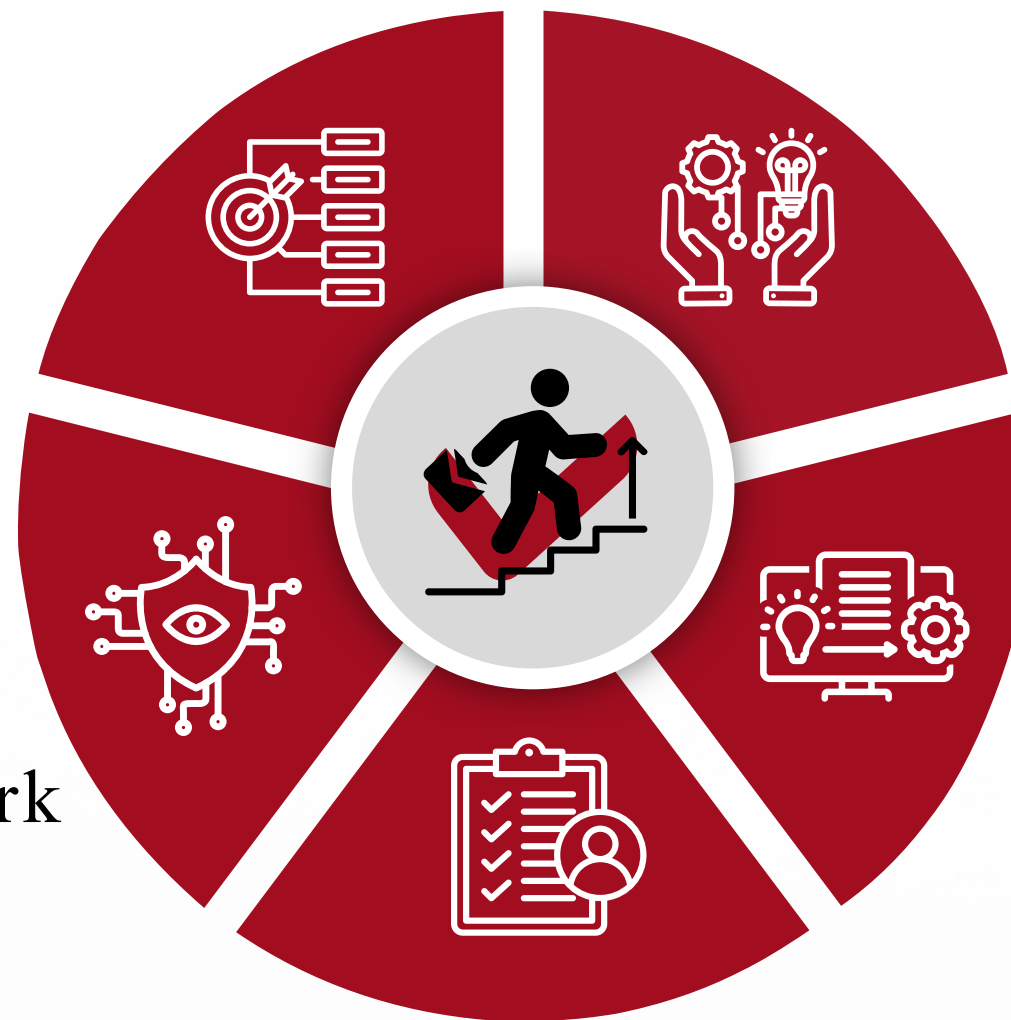

Intumescent Paint



Cementitious Paint



Work Images



STRUCTURAL ACTIVITIES

Concrete



STRUCTURAL ACTIVITIES

Concrete Repair & Corrosion Protection



STRUCTURAL ACTIVITIES

Concrete Jacketing



STRUCTURAL ACTIVITIES

Injection Work

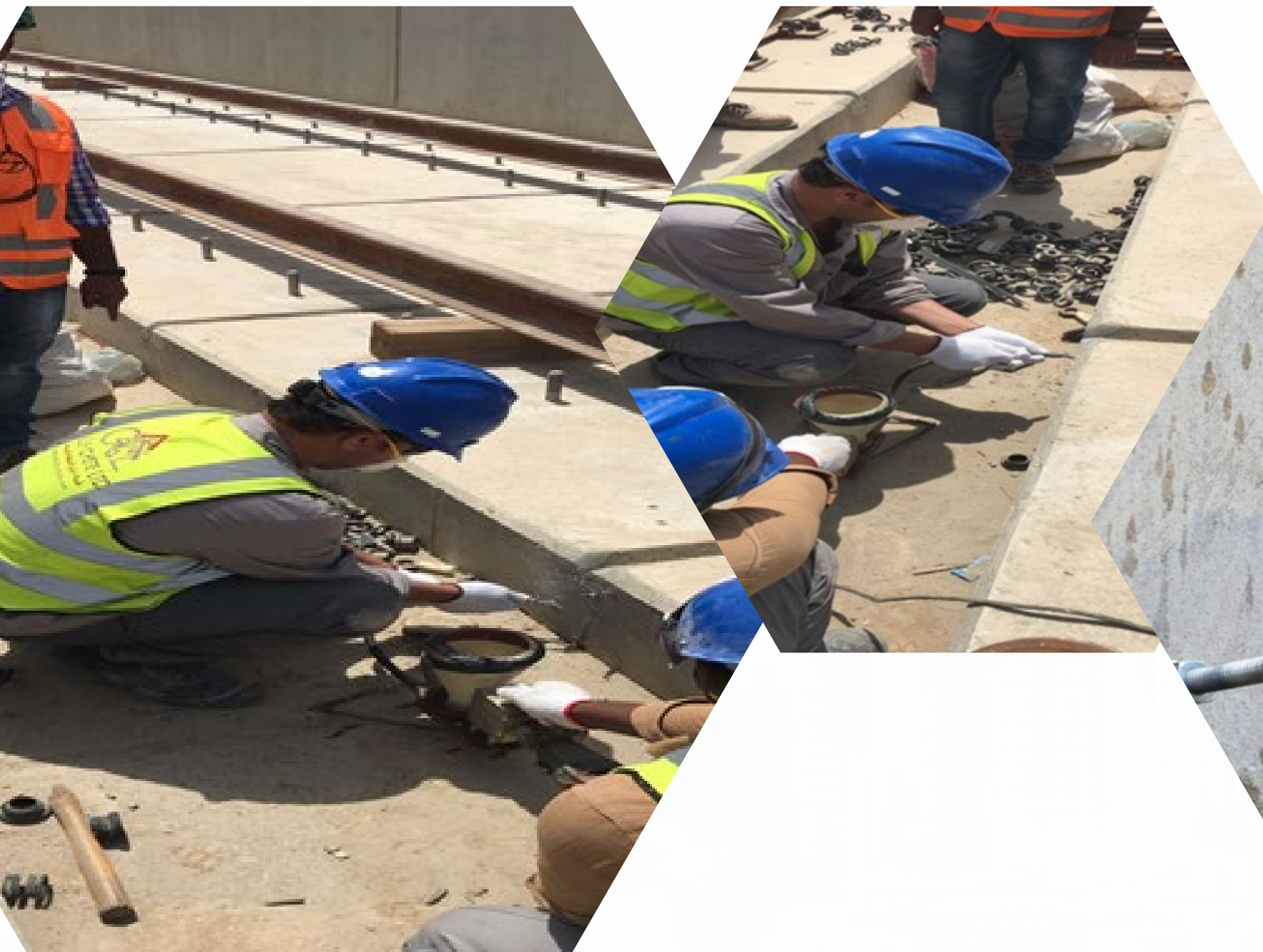

STRUCTURAL ACTIVITIES

Cathodic Protection



STRUCTURAL ACTIVITIES

CFRP

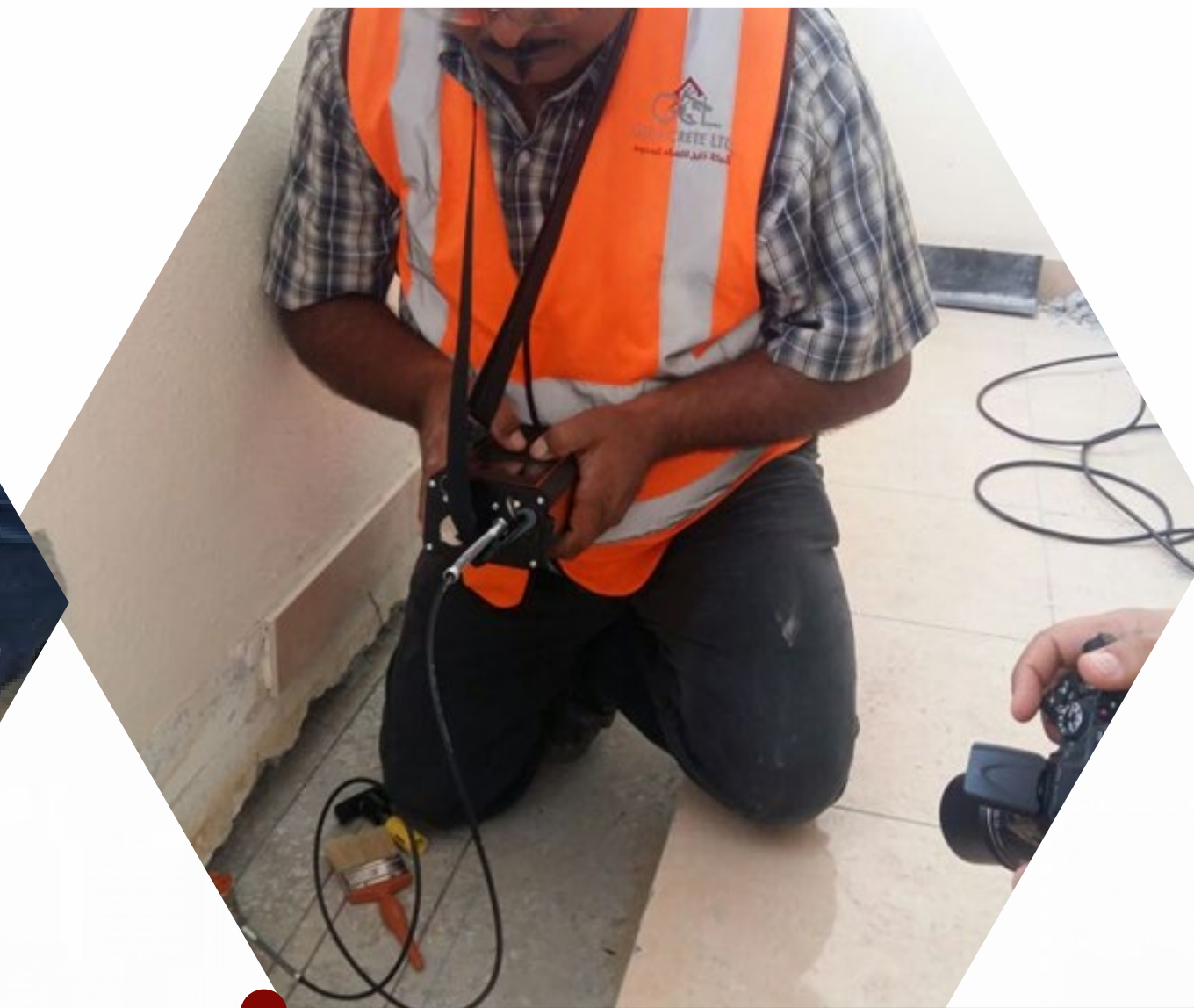

STRUCTURAL ACTIVITIES

CFRP



STRUCTURAL ACTIVITIES

3 D CONSTRUCTION SYSTEM

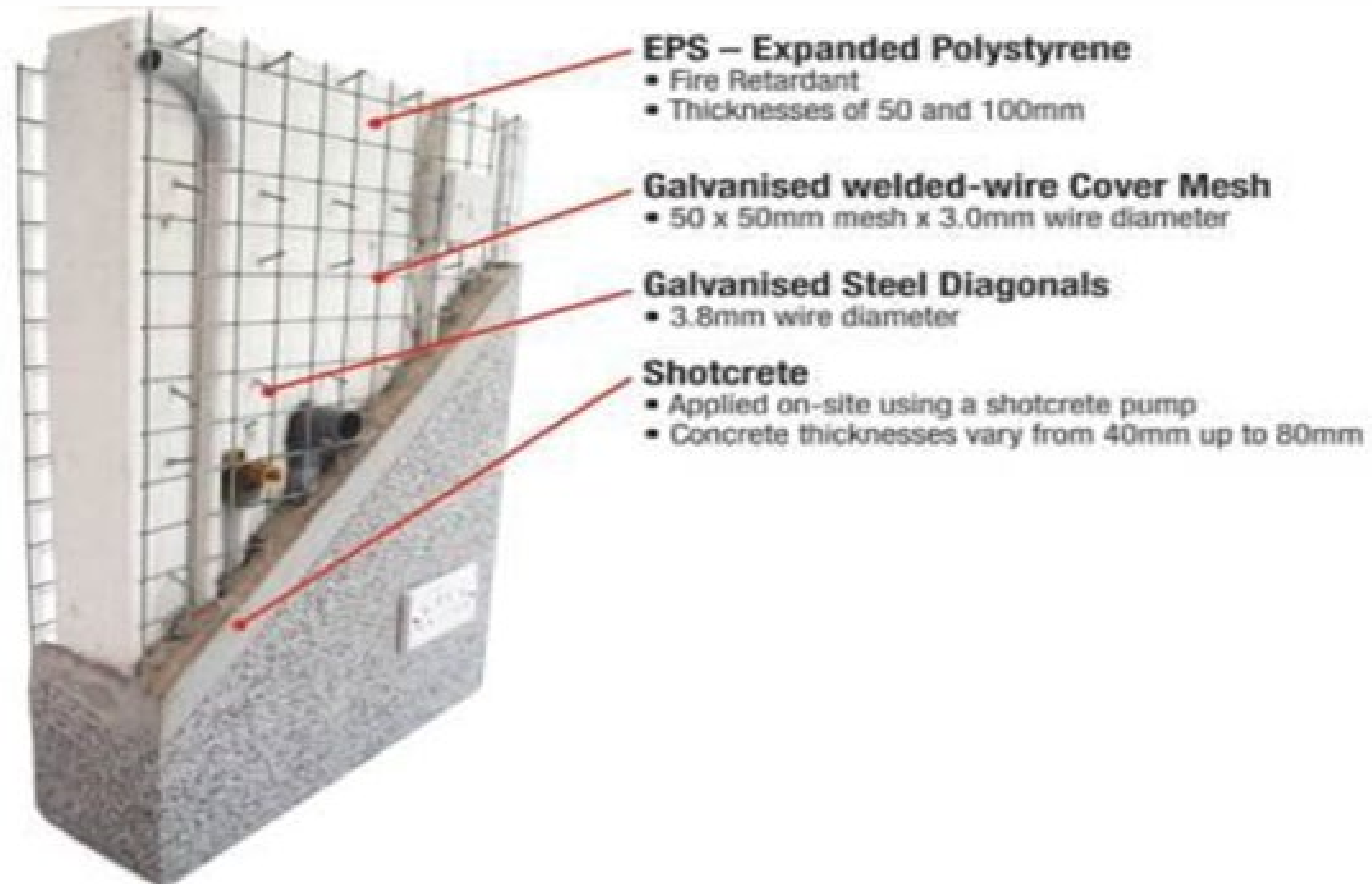

STRUCTURAL ACTIVITIES

3 D CONSTRUCTION SYSTEM

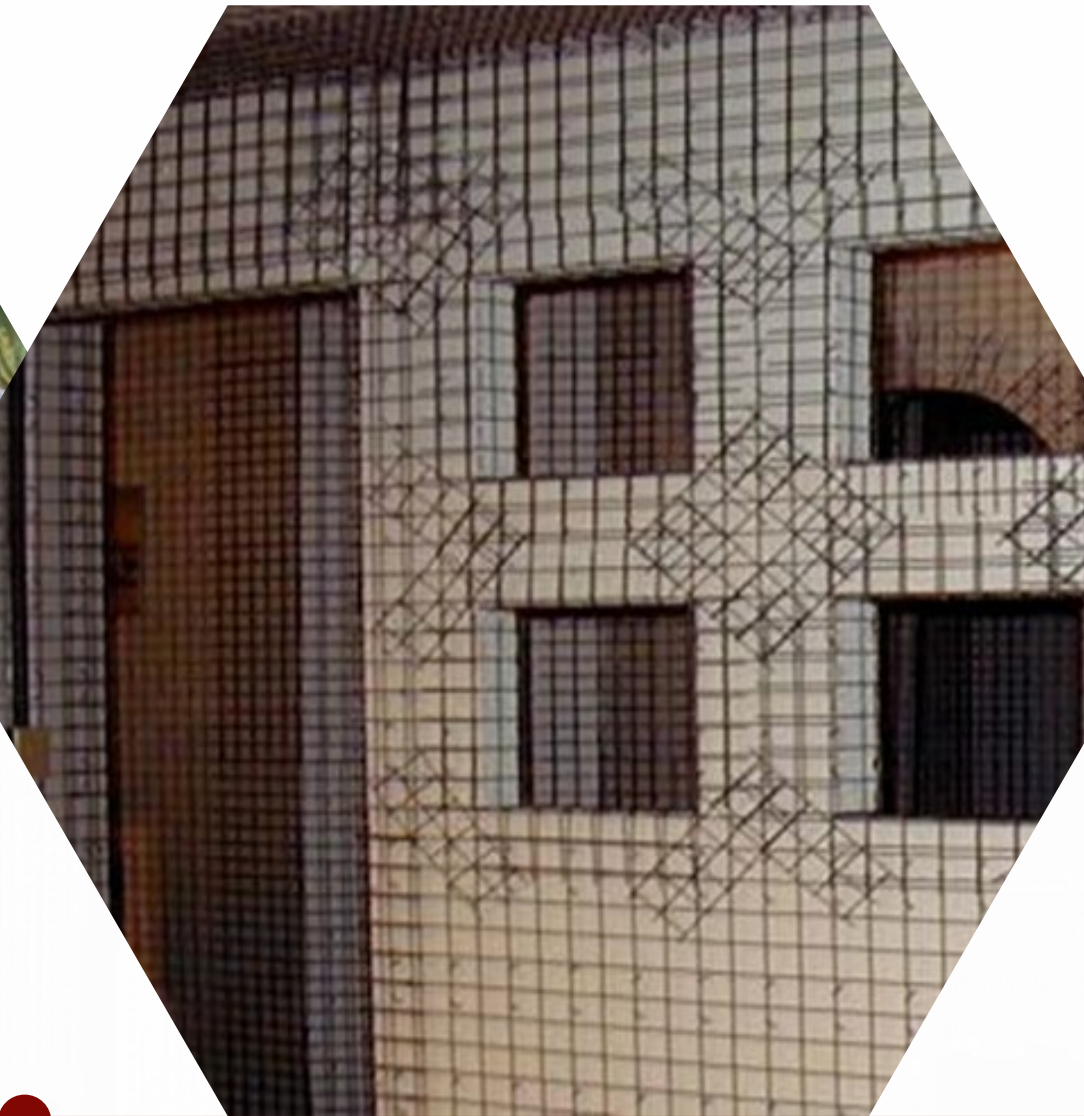
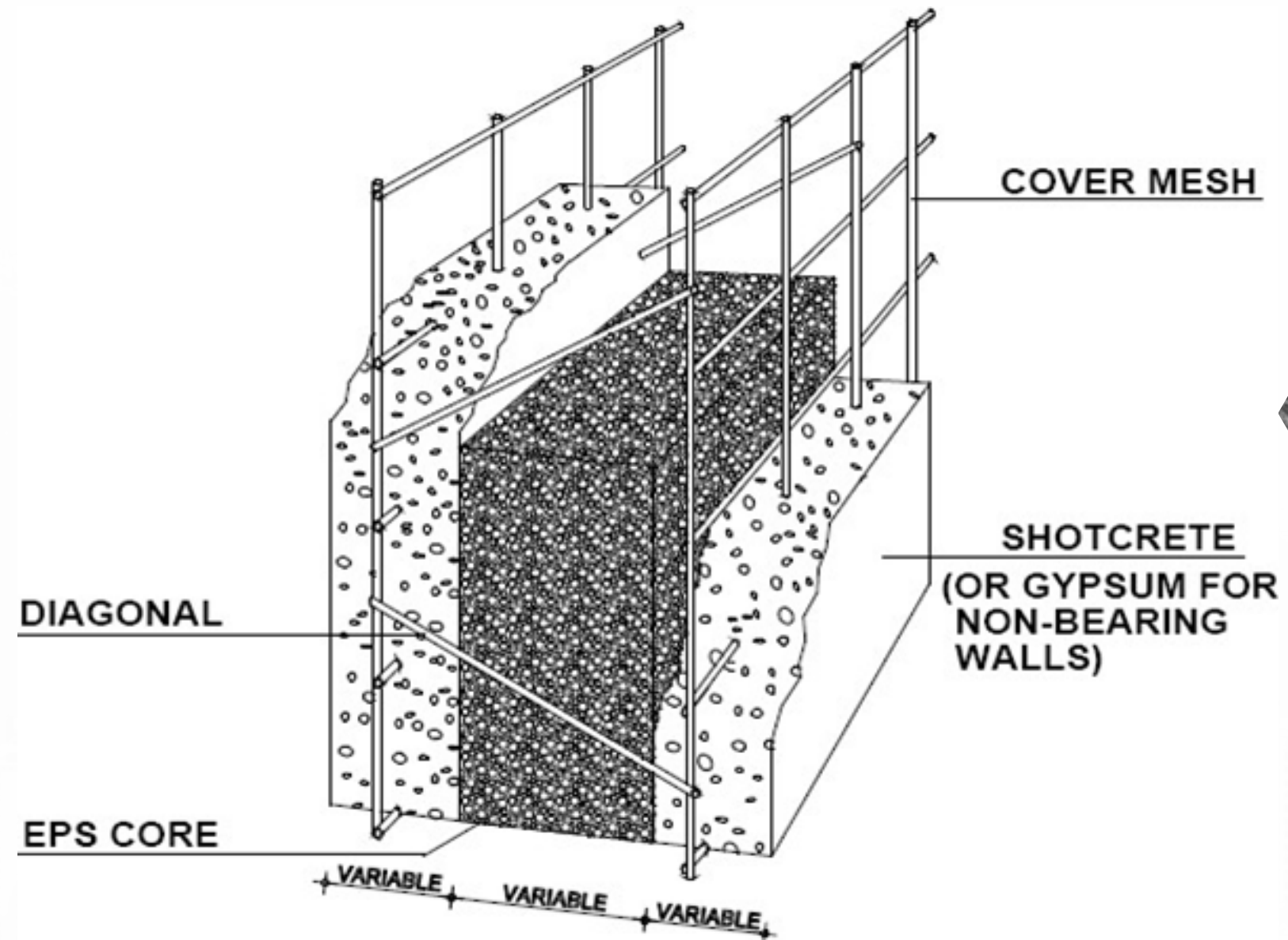

STRUCTURAL ACTIVITIES

Soil Injection



STRUCTURAL ACTIVITIES

Soil Injection



STRUCTURAL ACTIVITIES

Soil Injection



STRUCTURAL ACTIVITIES

Rock Bolts



STRUCTURAL ACTIVITIES

Rock Bolts



STRUCTURAL ACTIVITIES

Shotcrete



STRUCTURAL ACTIVITIES

Shotcrete

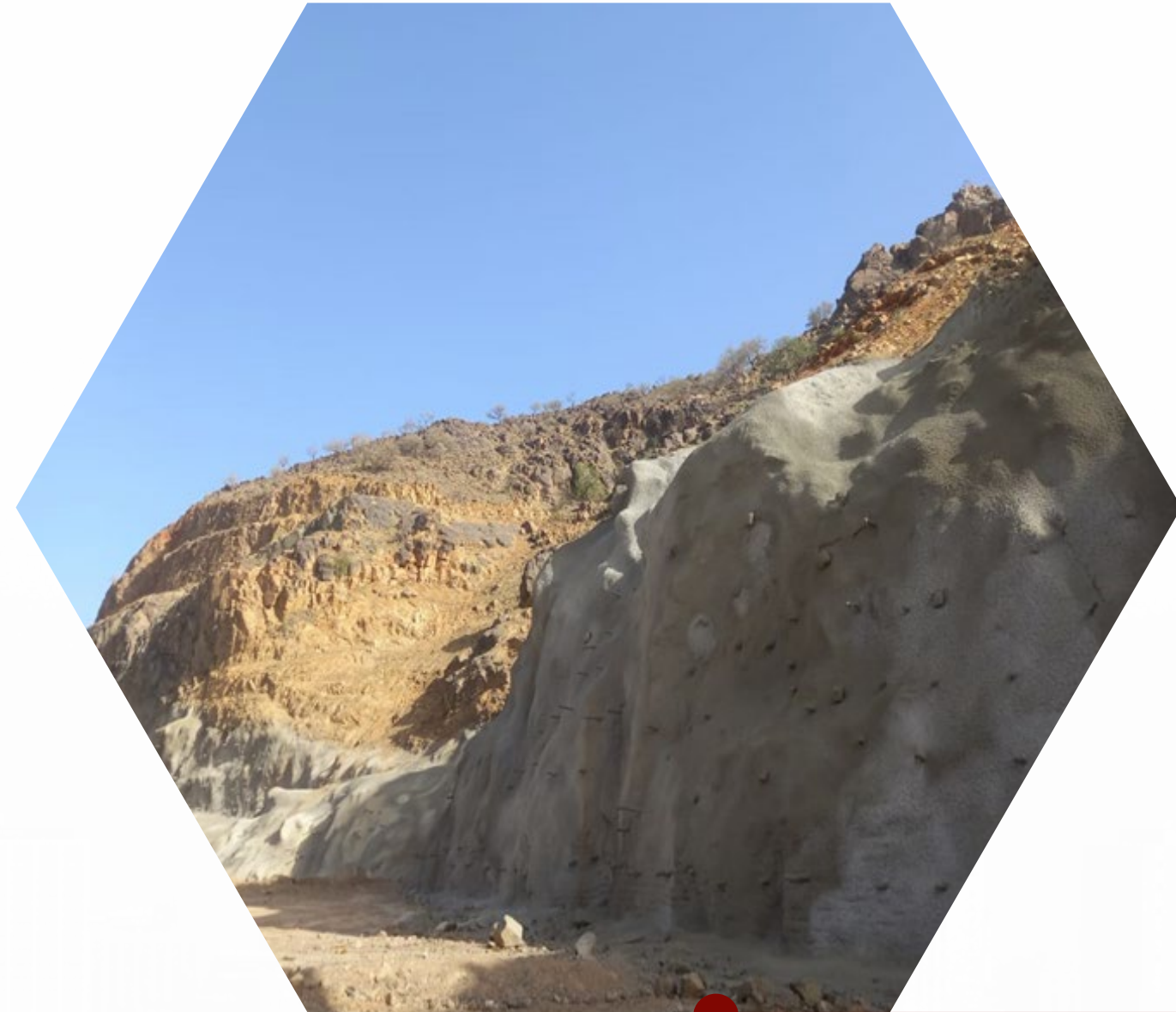
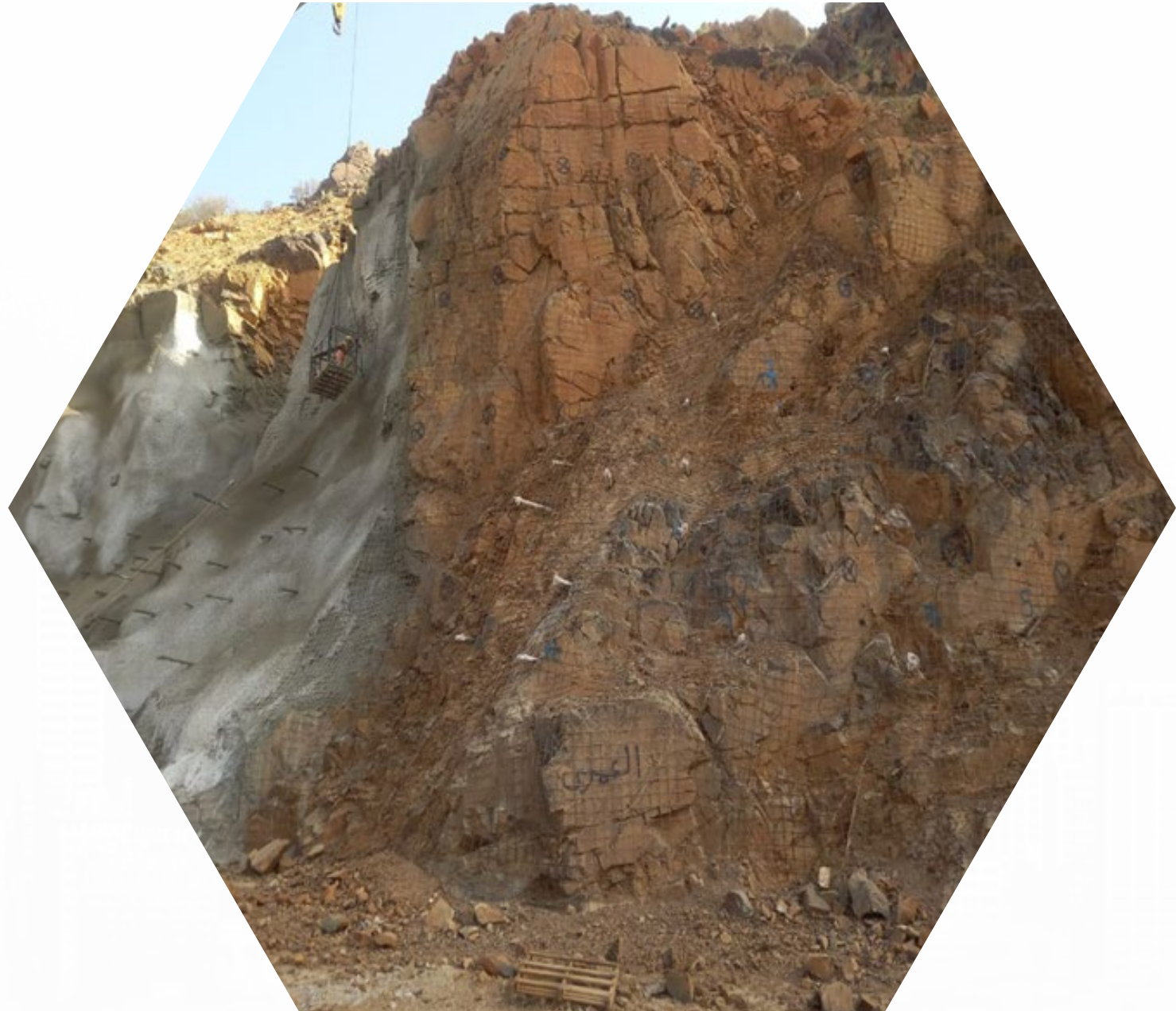

STRUCTURAL ACTIVITIES

Micro Piles

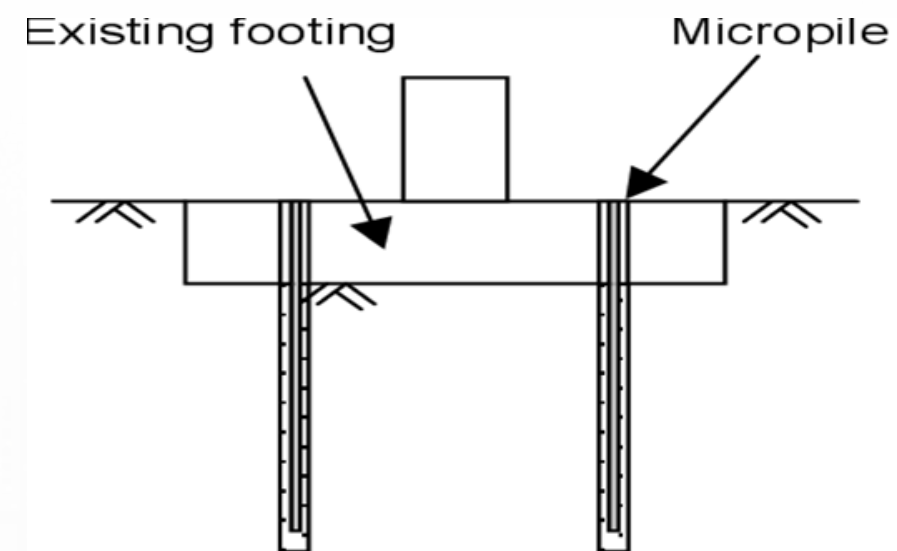

Micropiles through existing footing

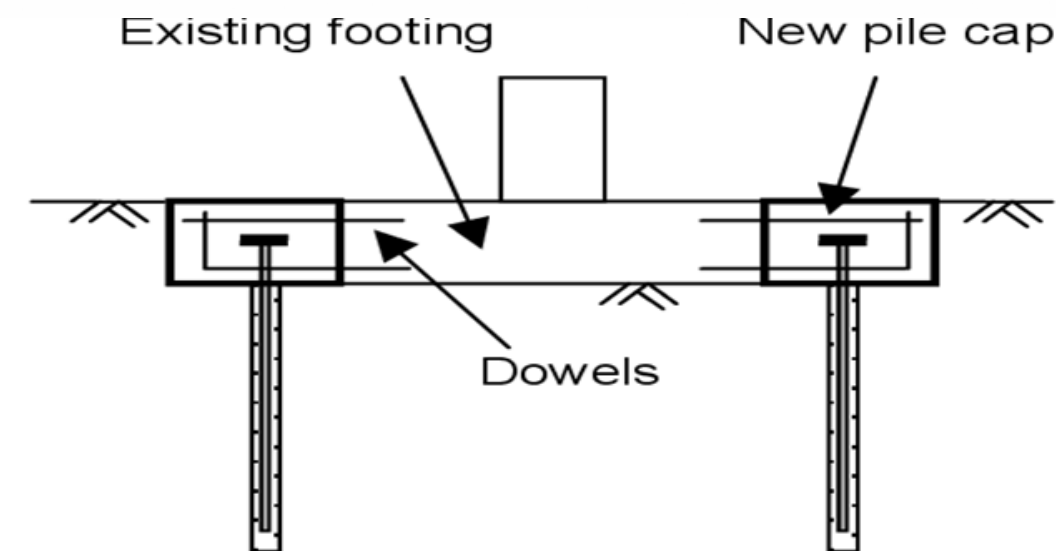

New pile cap attached to existing footing

RockFall Protection

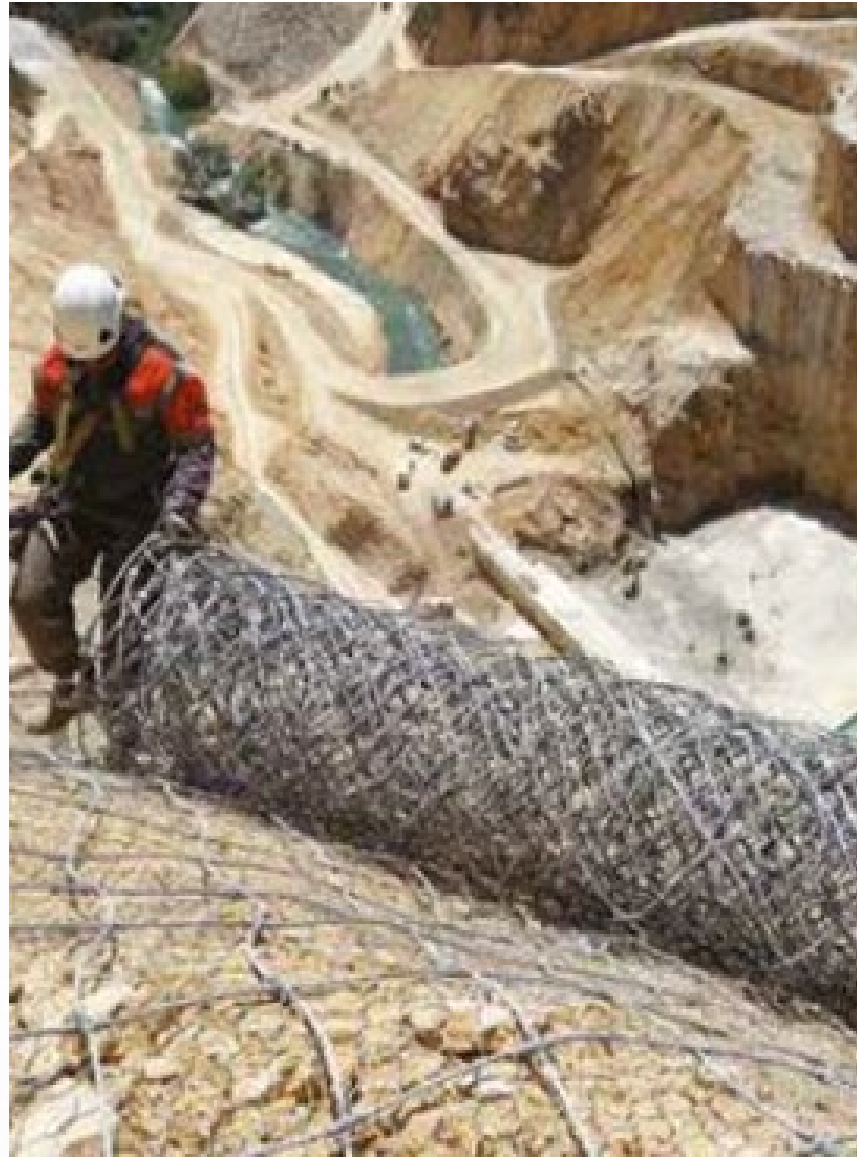

RockFall Protection



RockFall Protection



RockFall Protection



RockFall Protection

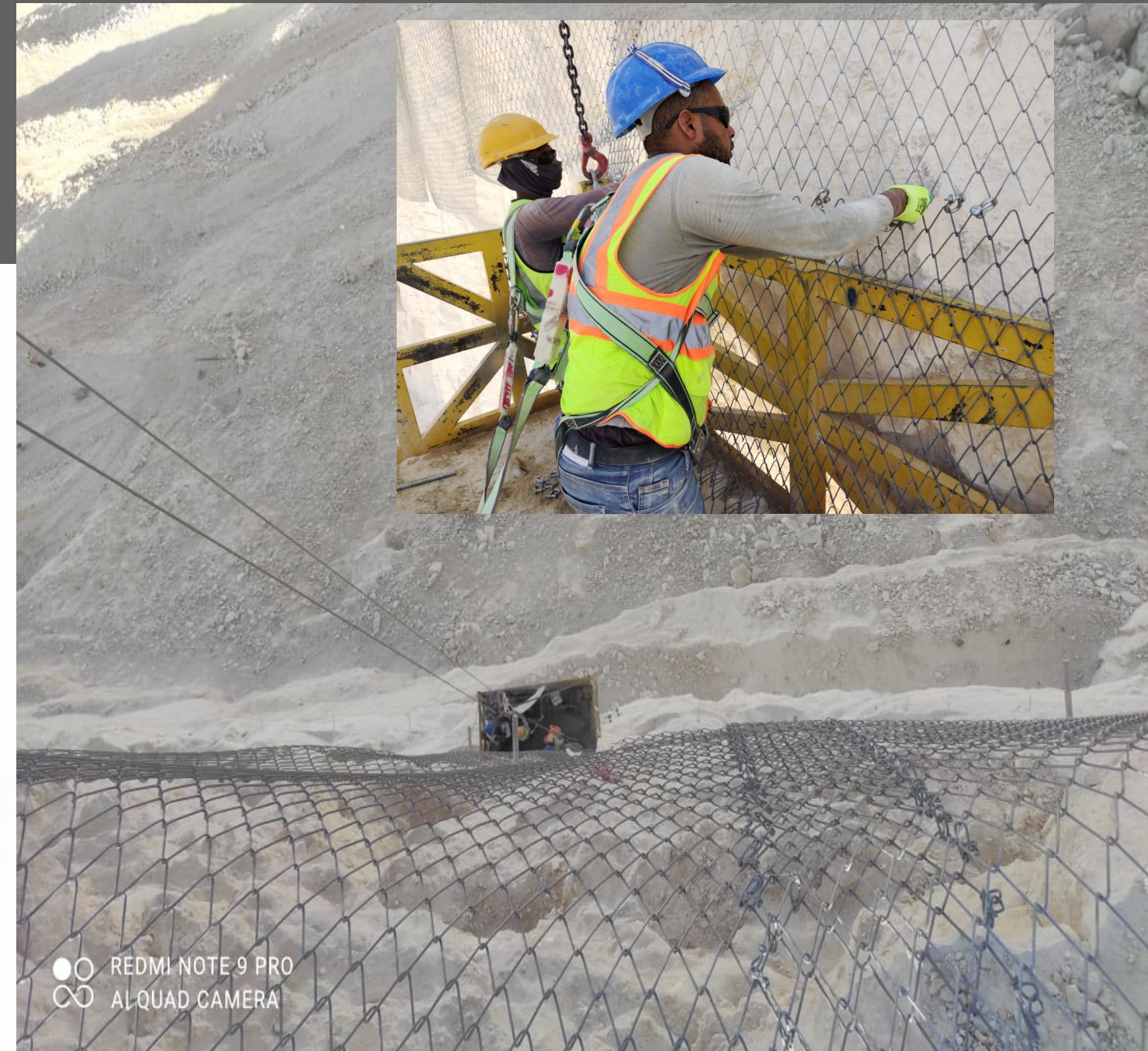
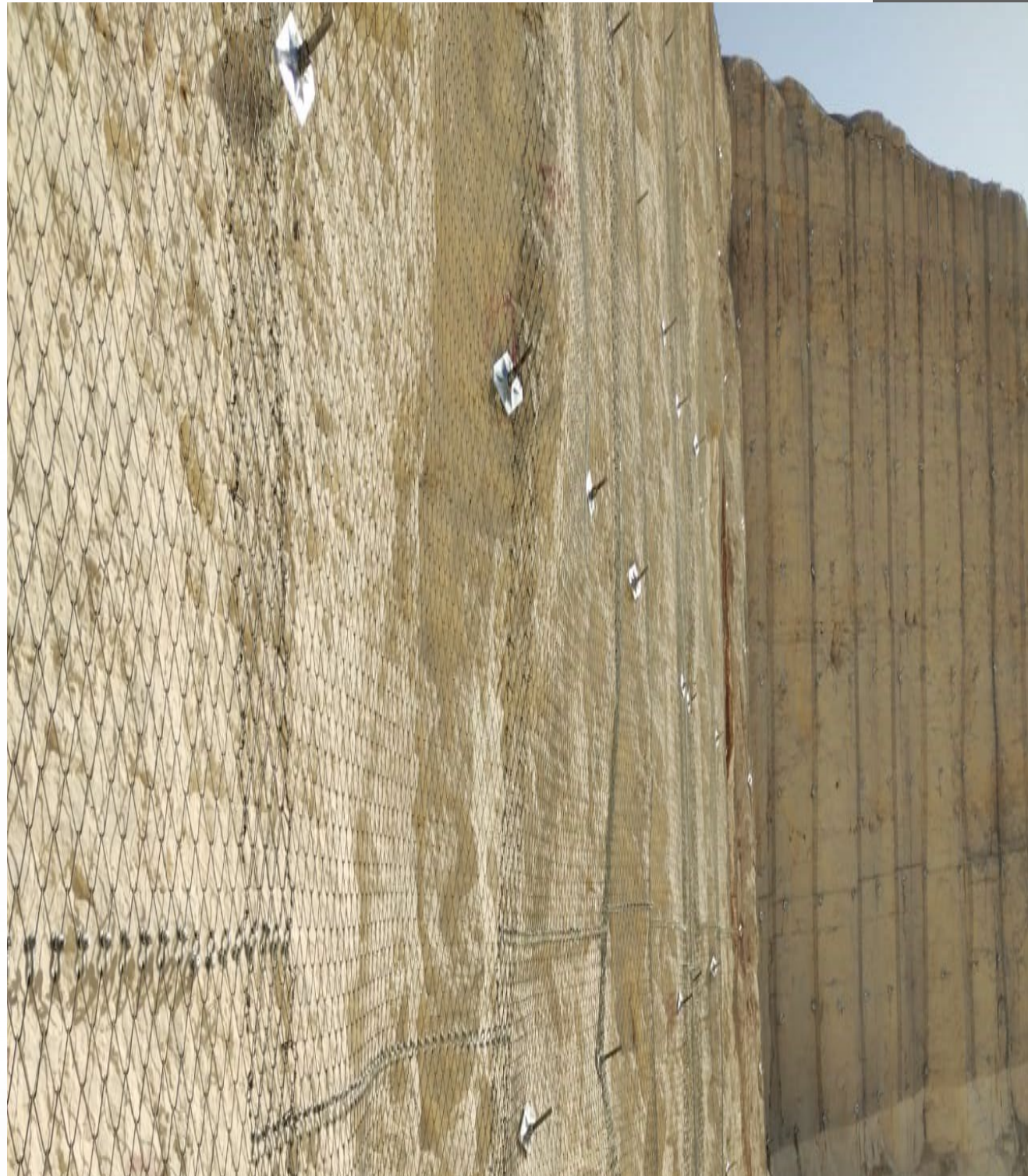

Survey Technology

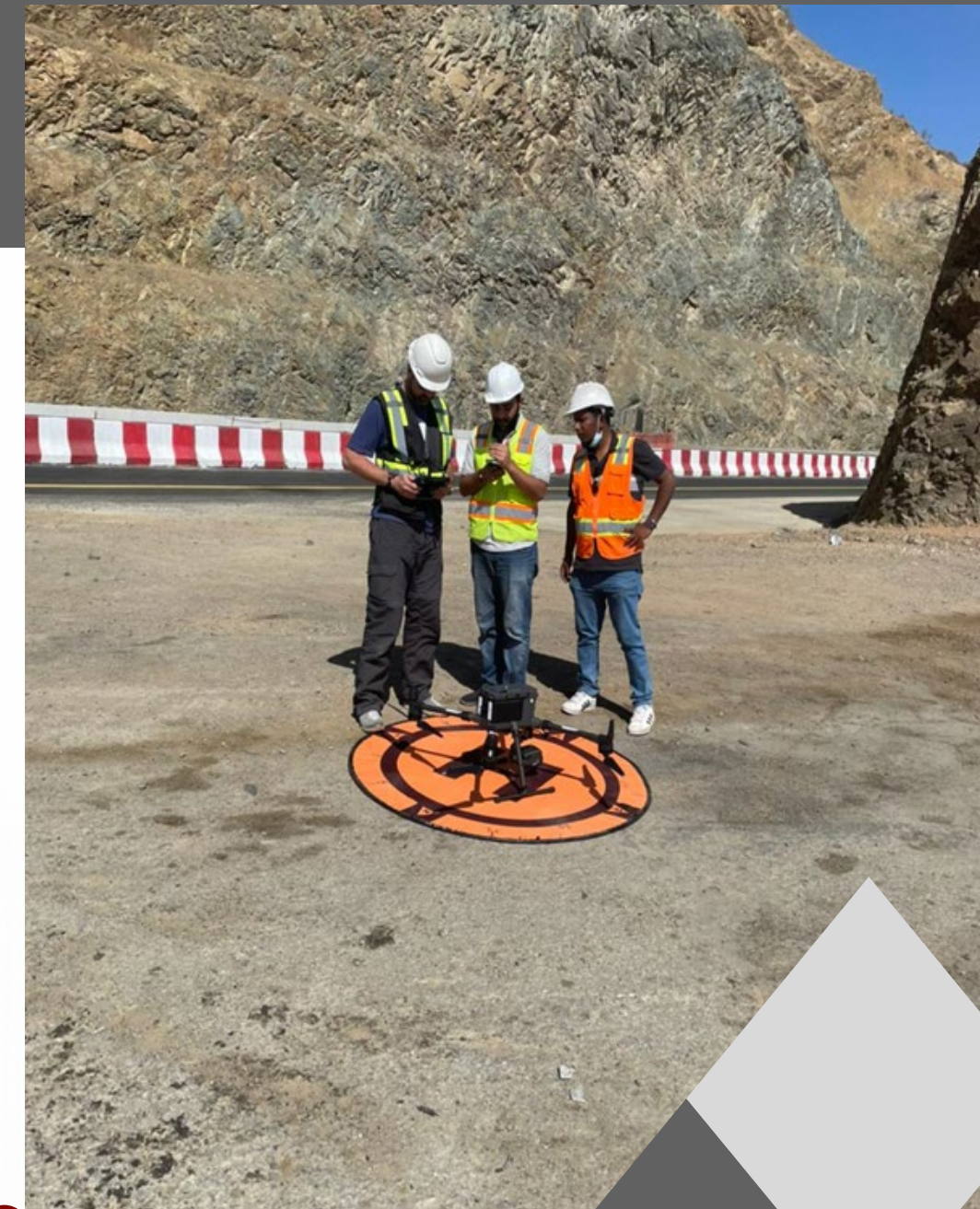

Survey Technology

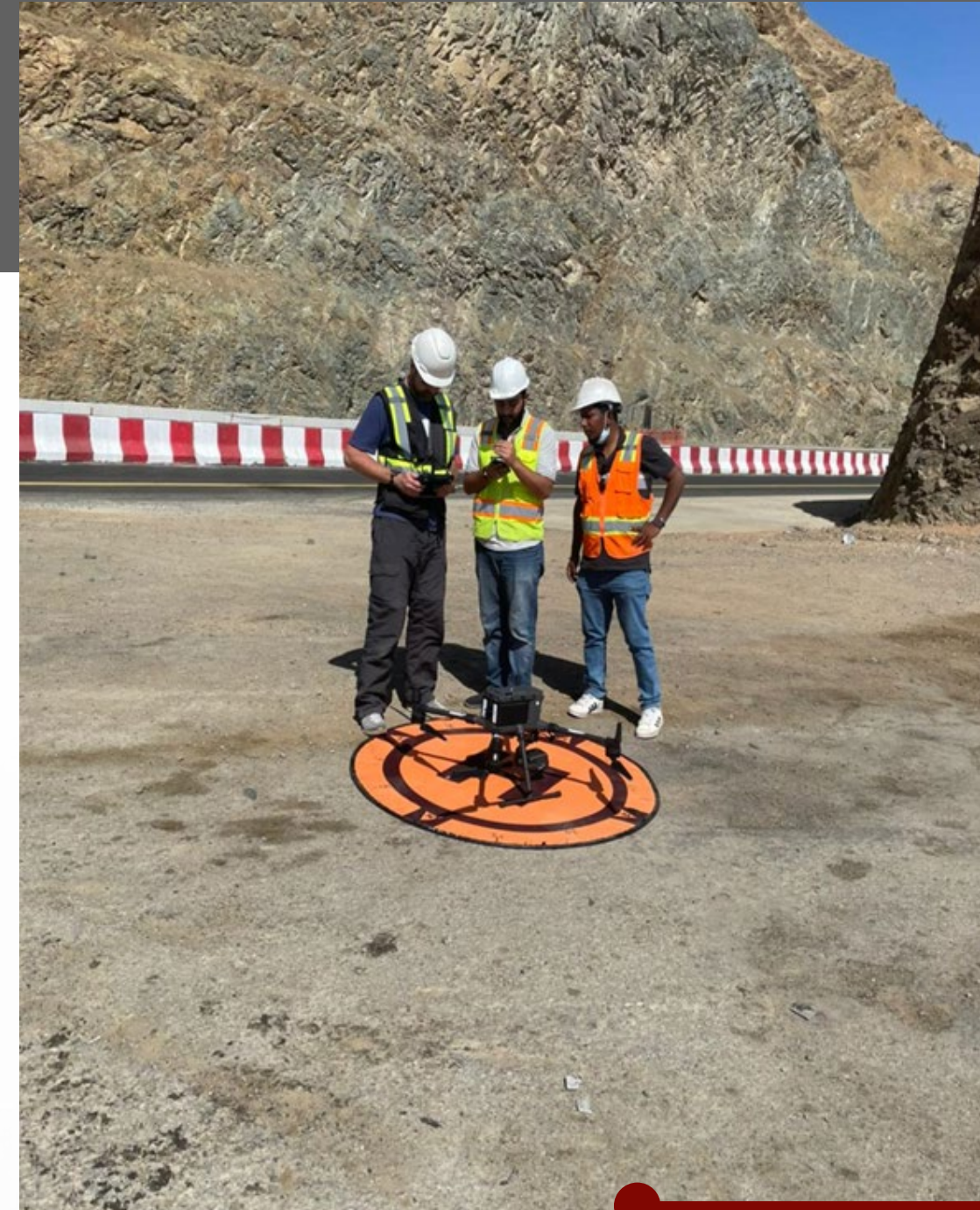
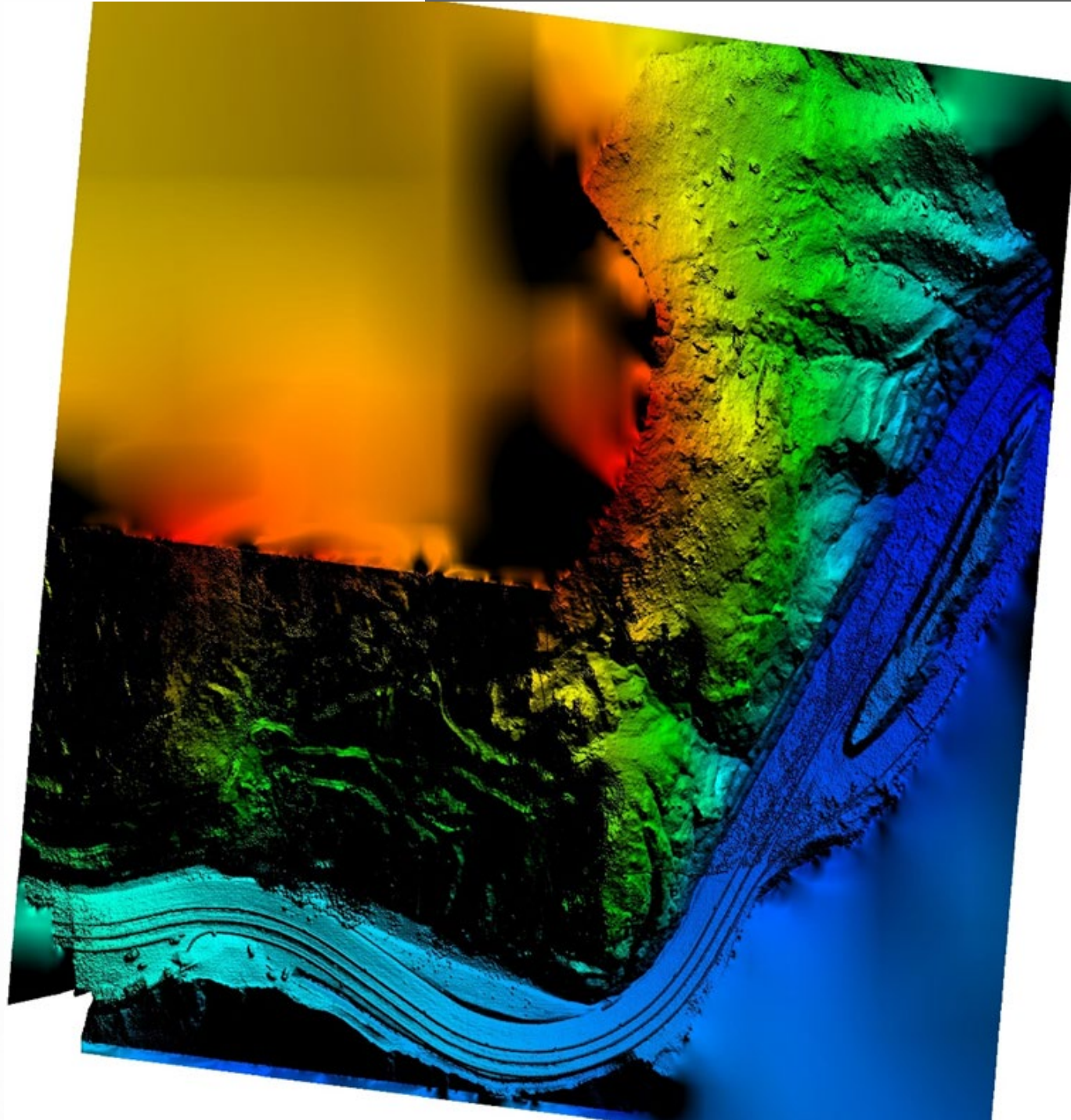

Survey Technology

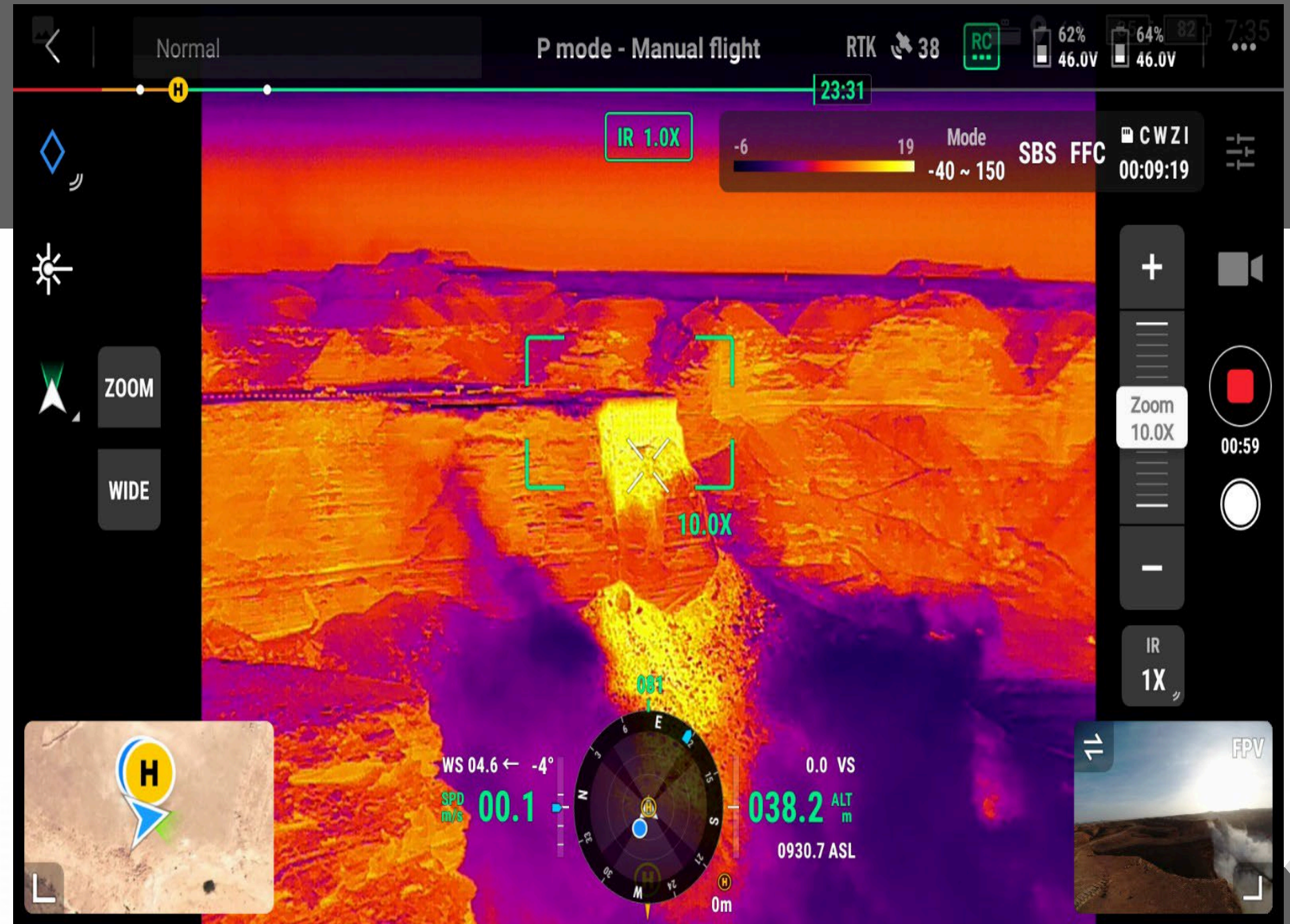
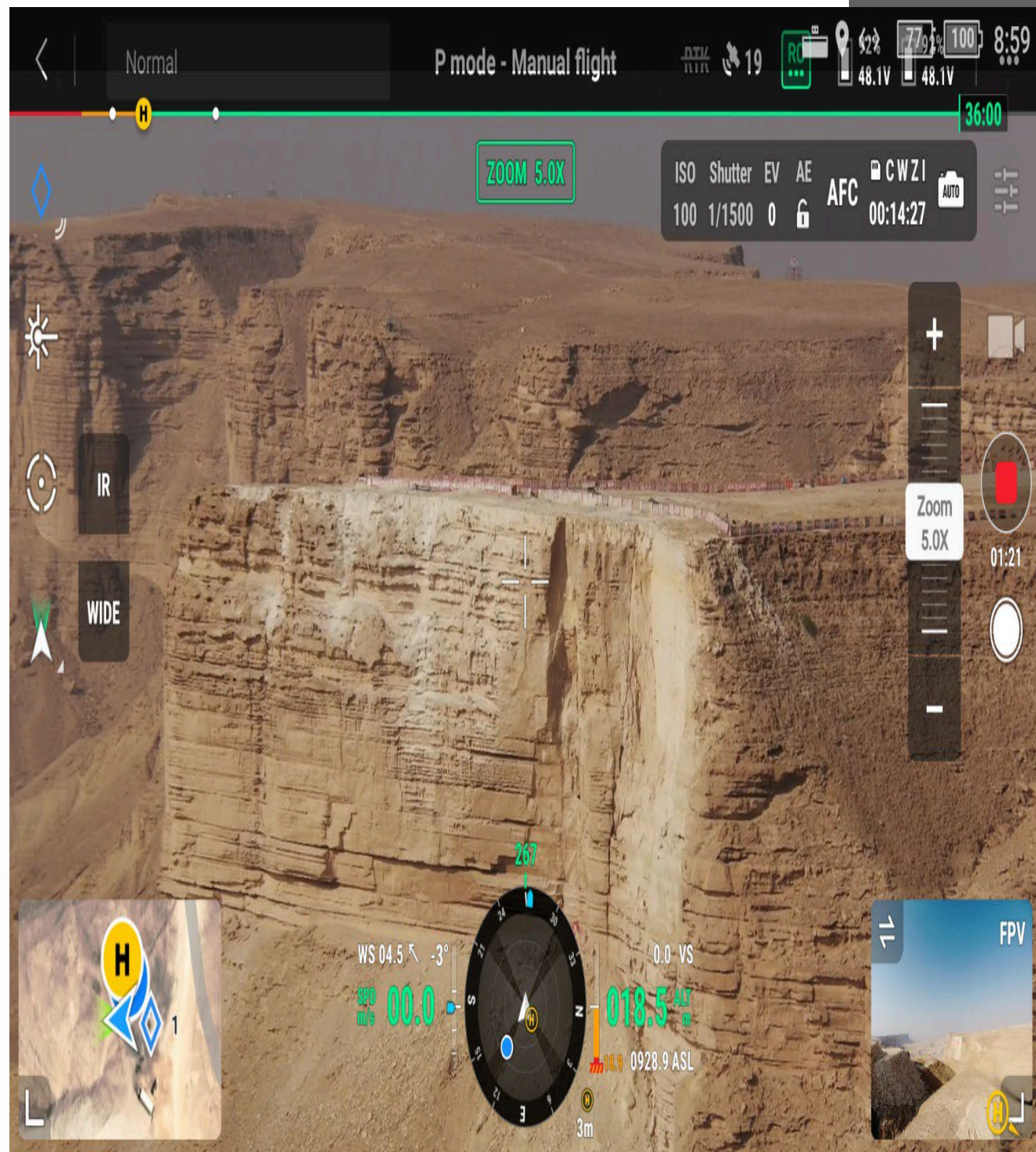

INDUSTRIAL & COATING FLOORING ACTIVITIES

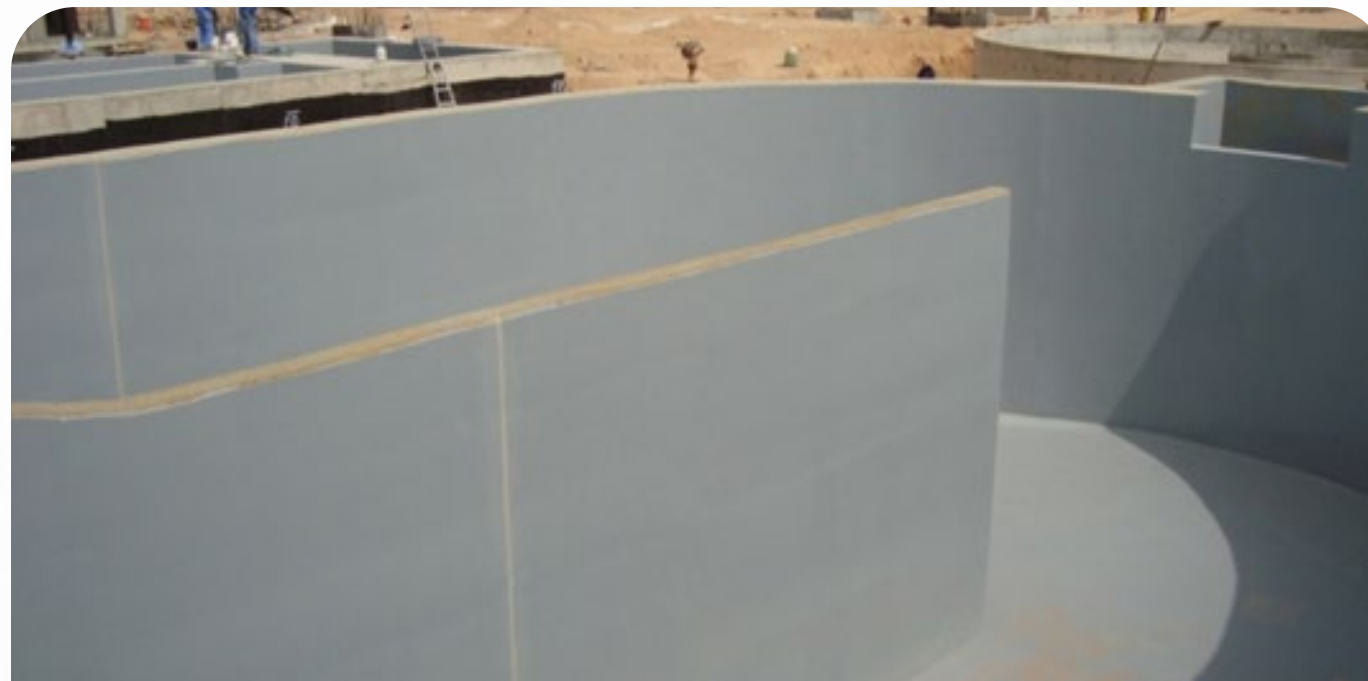
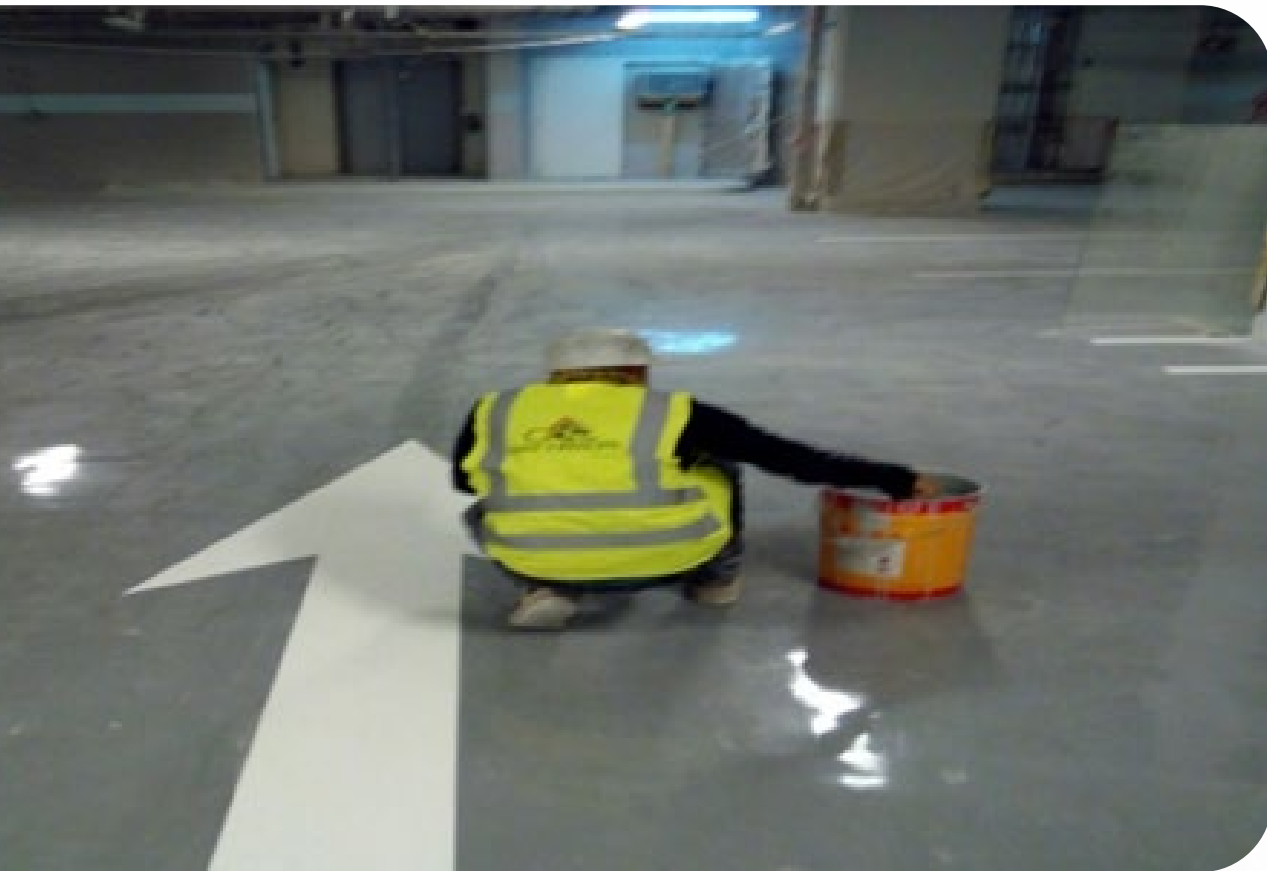

INDUSTRIAL FLOORING

Polyurethane and polyurea Coating



INDUSTRIAL FLOORING

Polyurethane and polyurea
Coating



INDUSTRIAL FLOORING

Epoxy Terrazzo Finishing



INDUSTRIAL FLOORING

Heavy Grinding for Floor Concrete

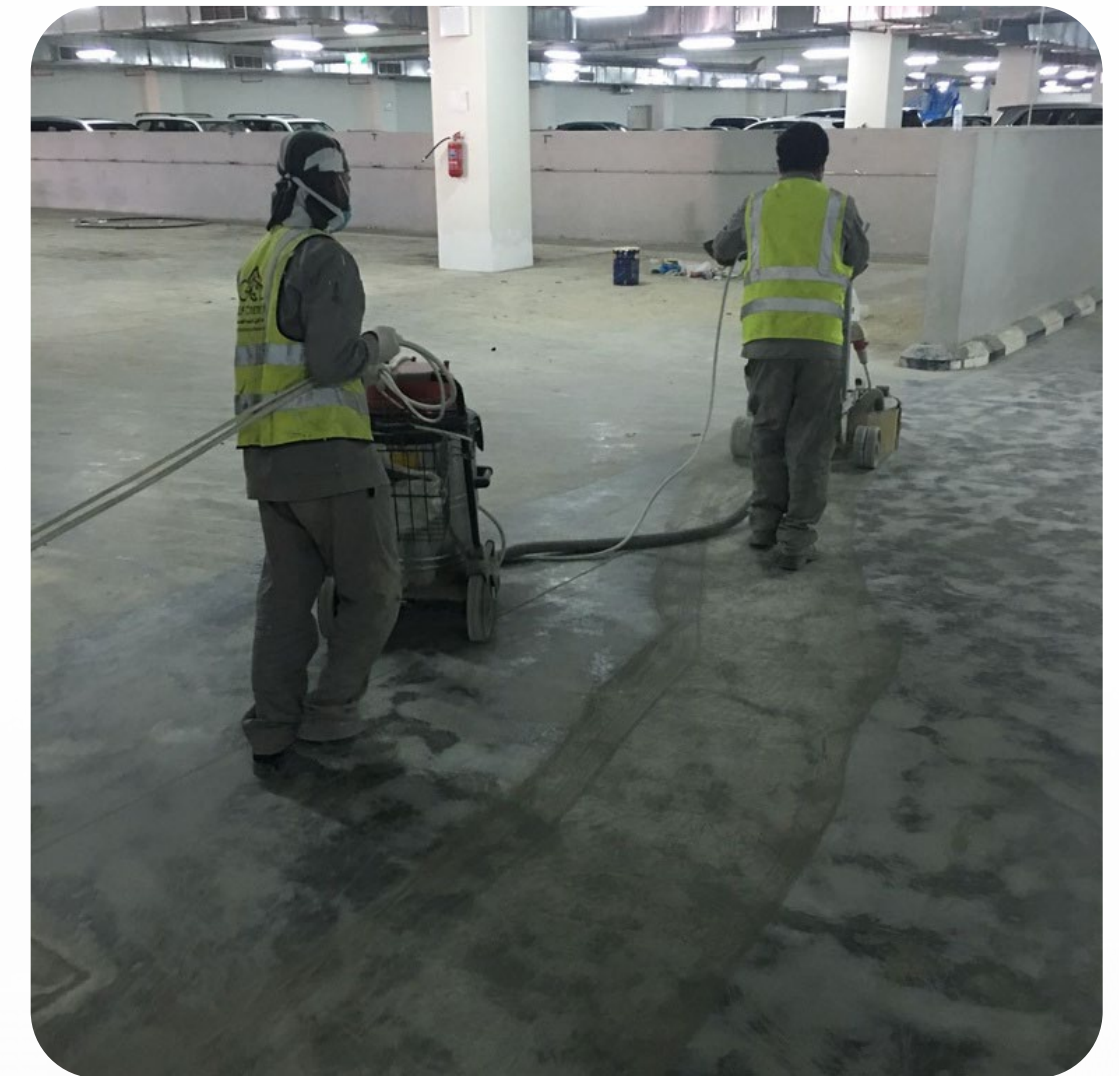
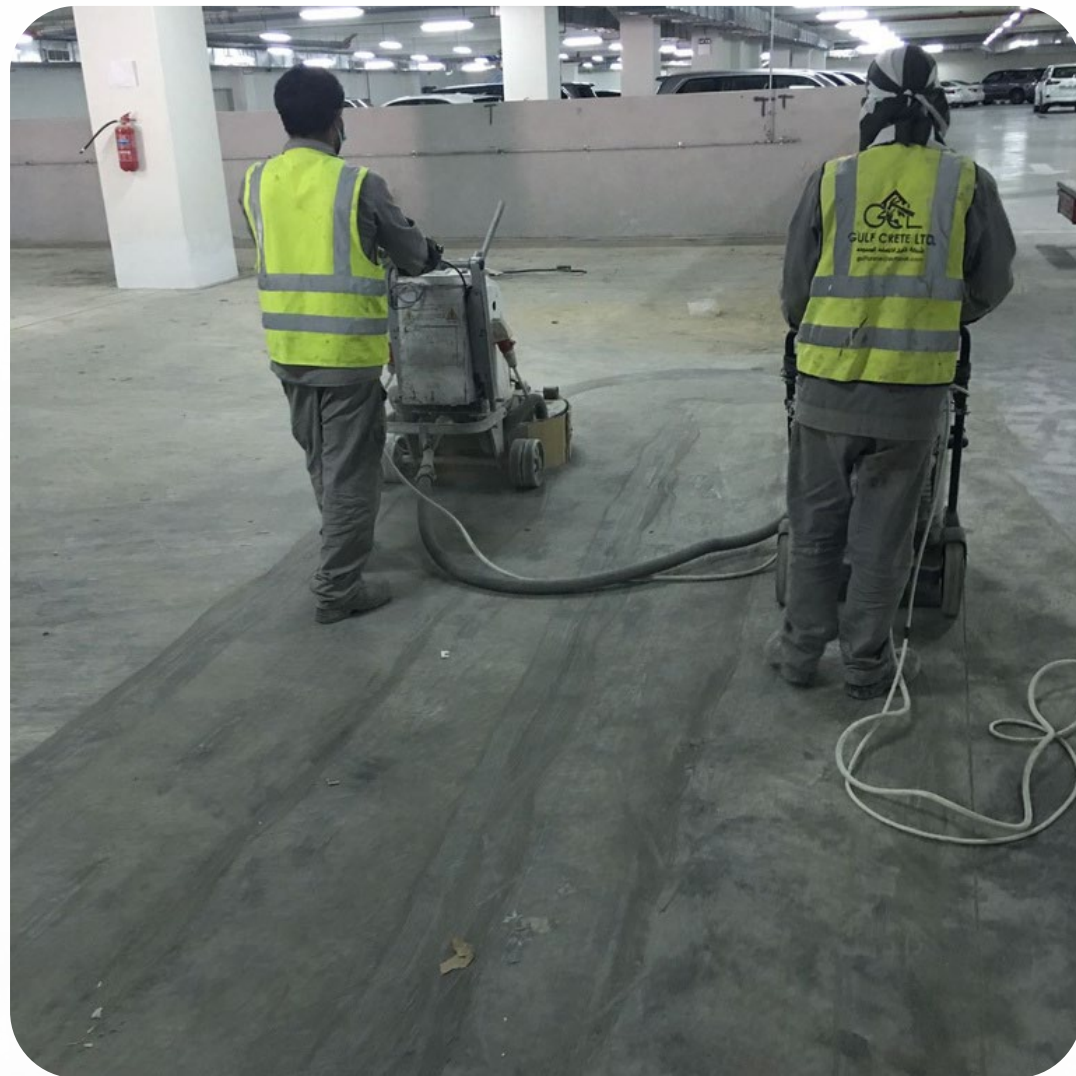

INDUSTRIAL FLOORING

Screed Casting

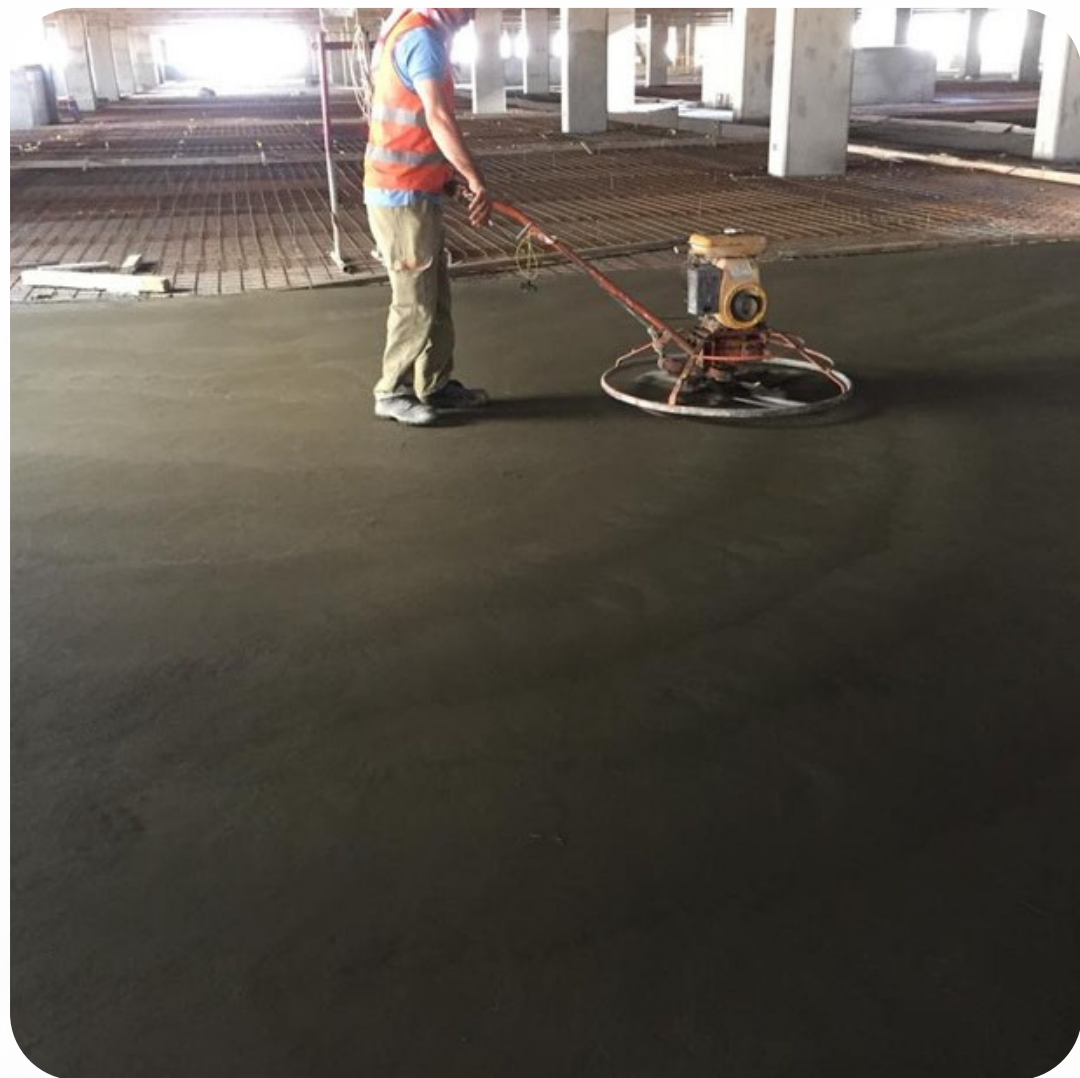

INDUSTRIAL FLOORING

Airport runways and helipads

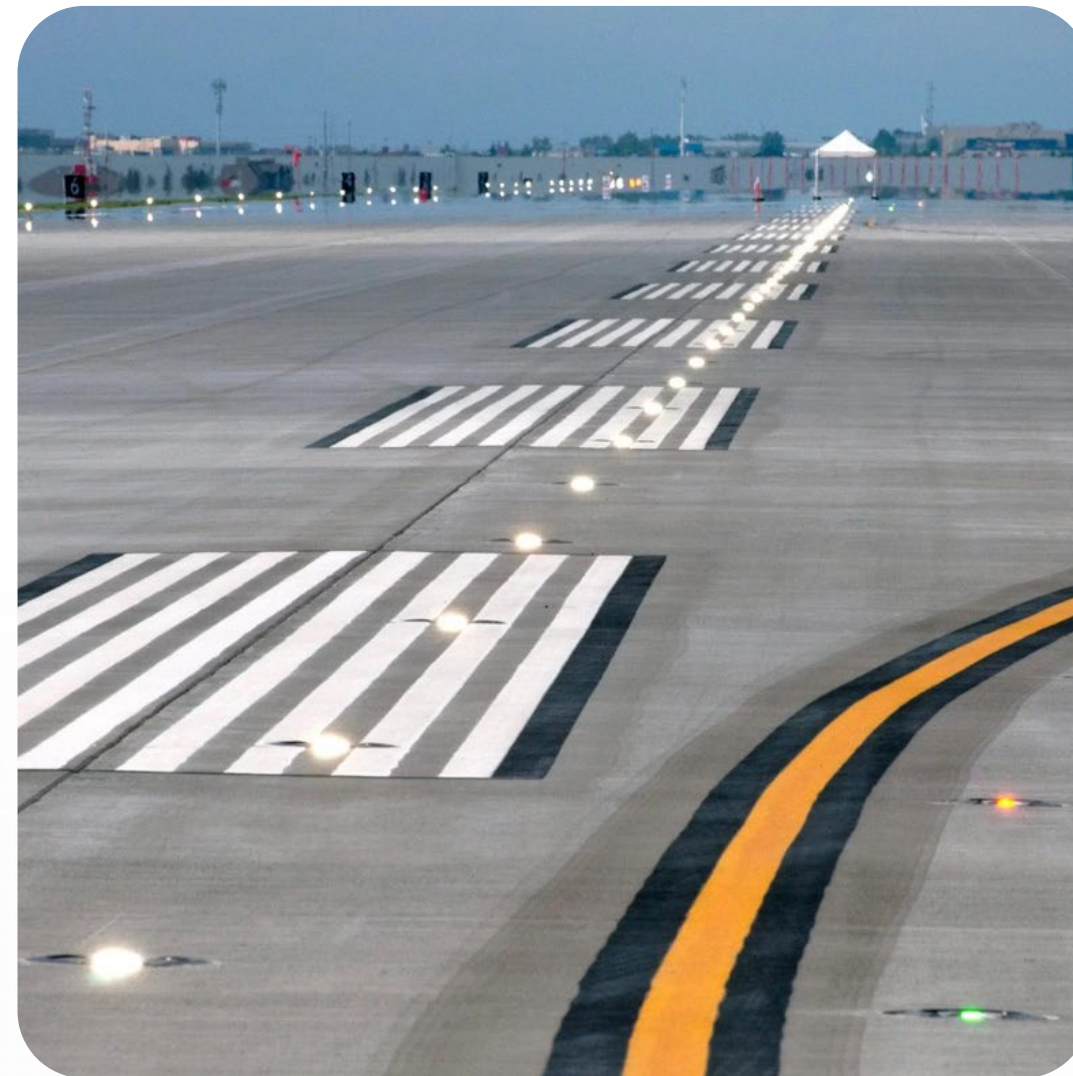

INDUSTRIAL FLOORING

Micro topping Flooring Coating

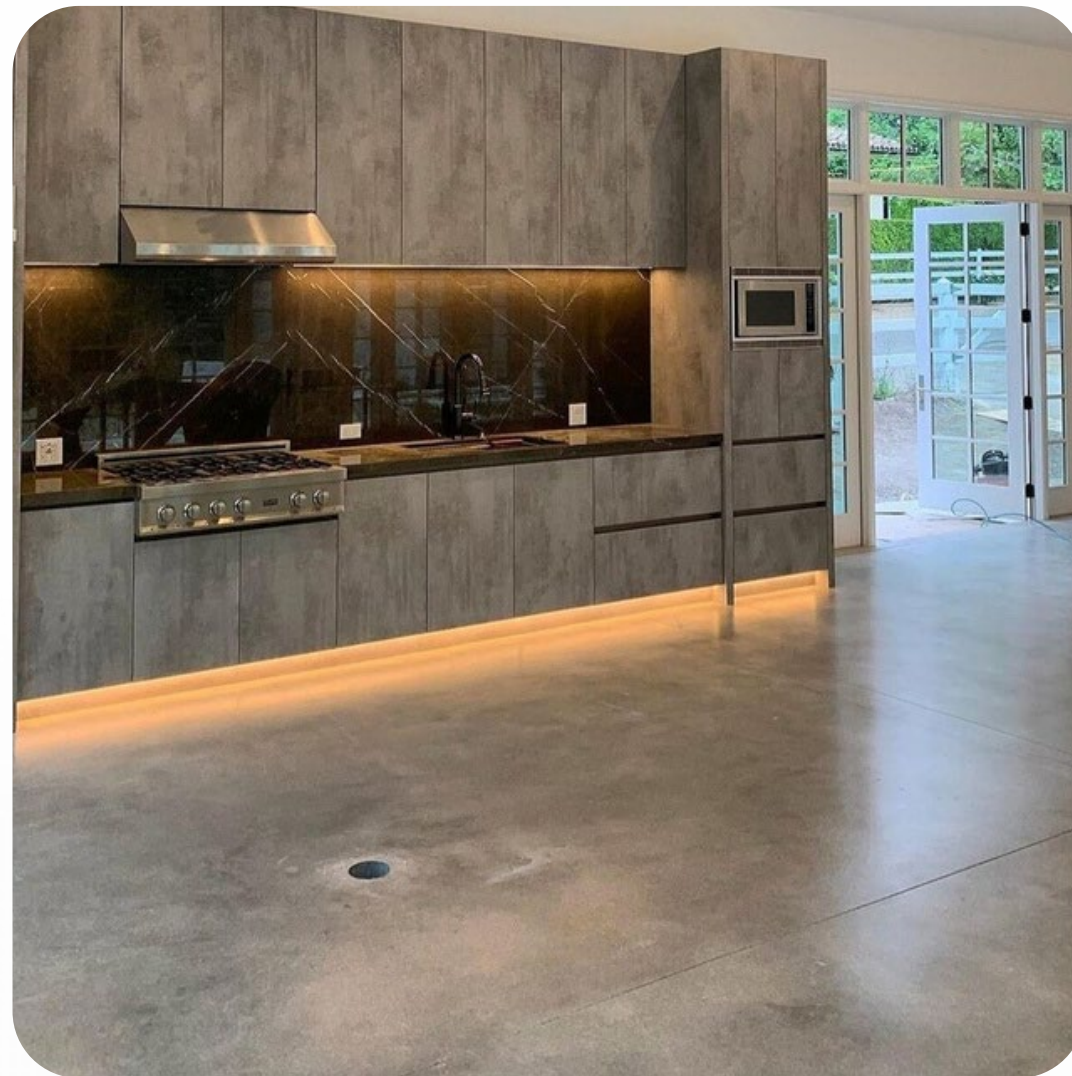

INDUSTRIAL FLOORING

Cementitious self leveling

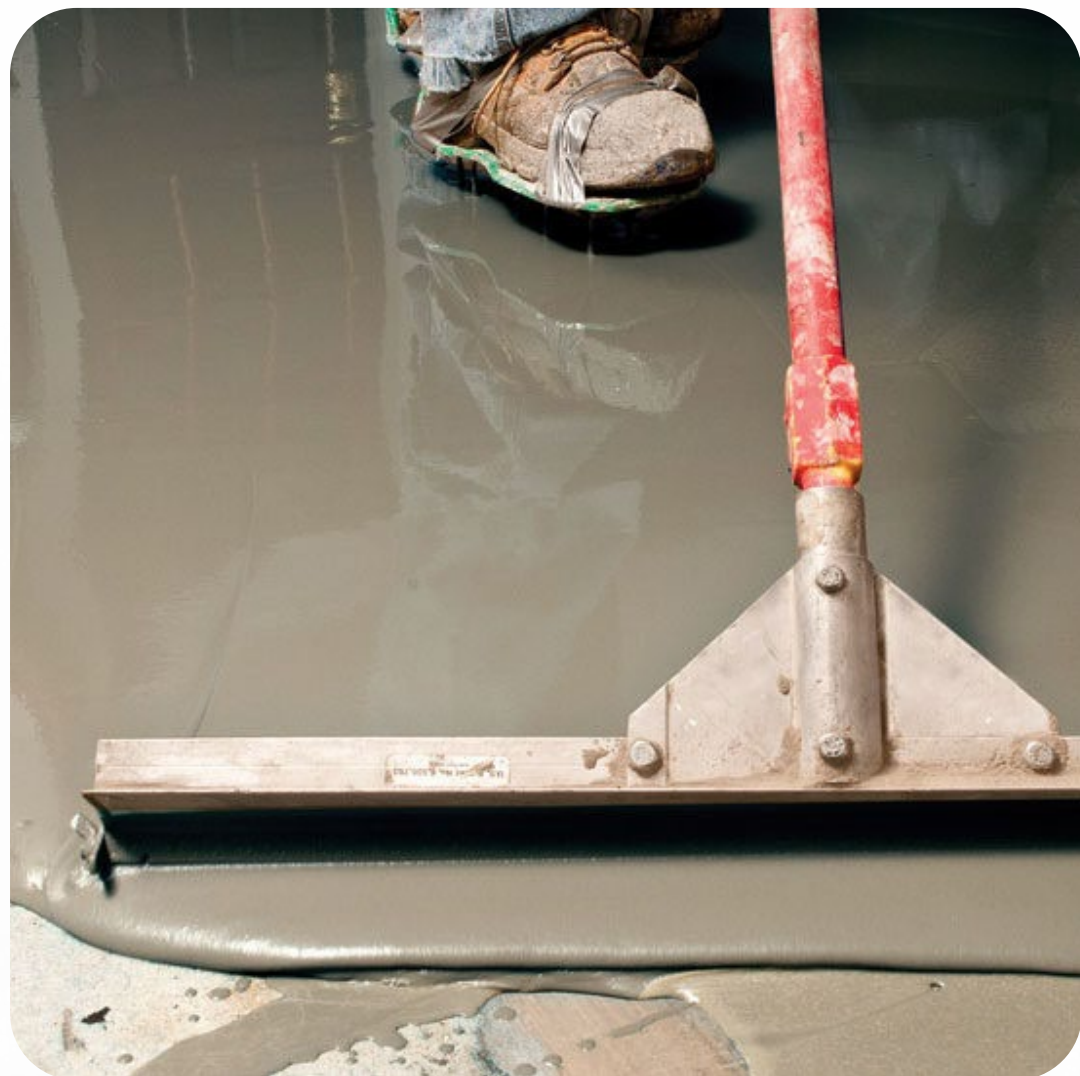

INDUSTRIAL FLOORING

Anti-Static Flooring

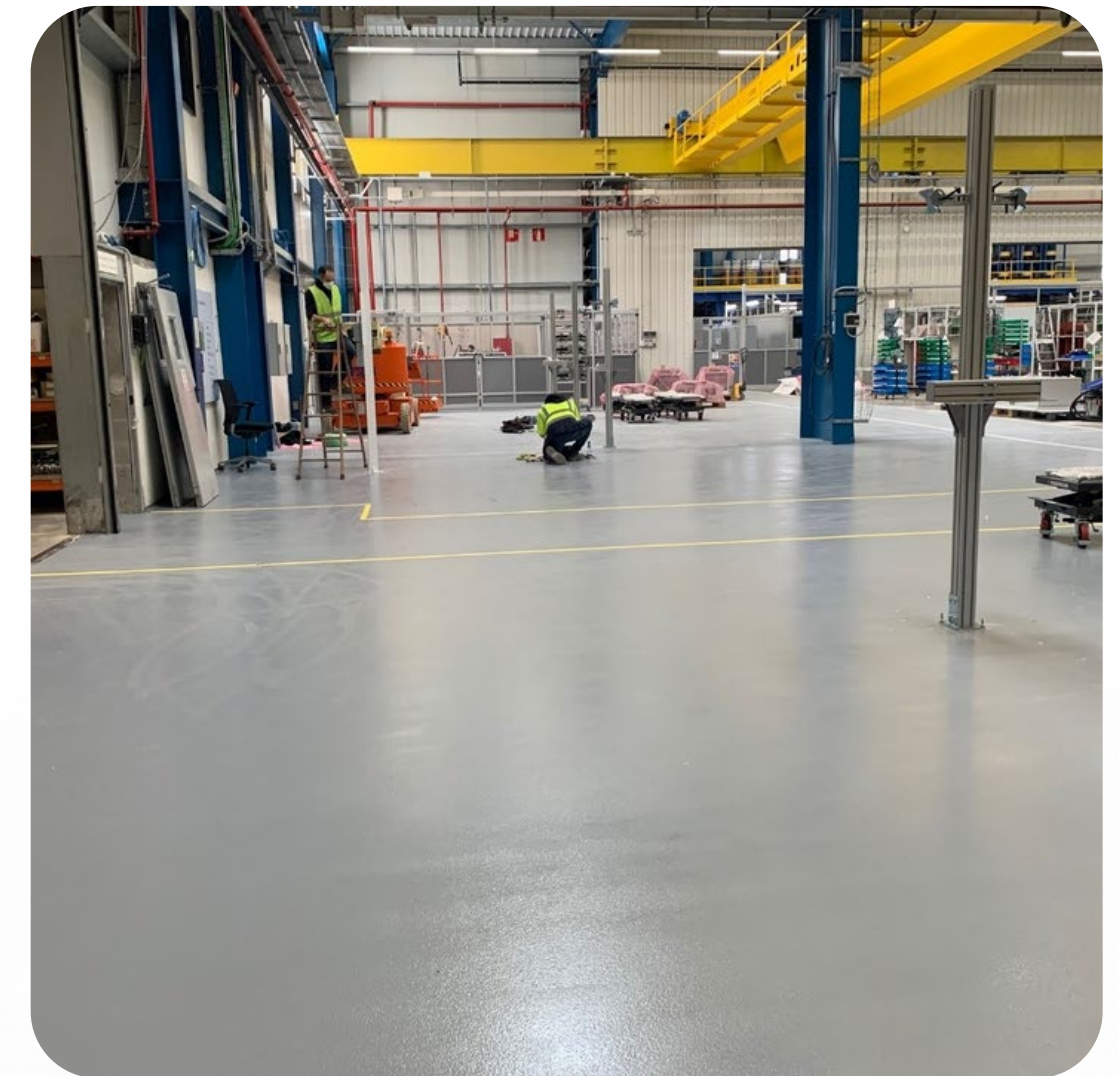

INDUSTRIAL FLOORING

Polyurethane Screed
(such as U-Crete)

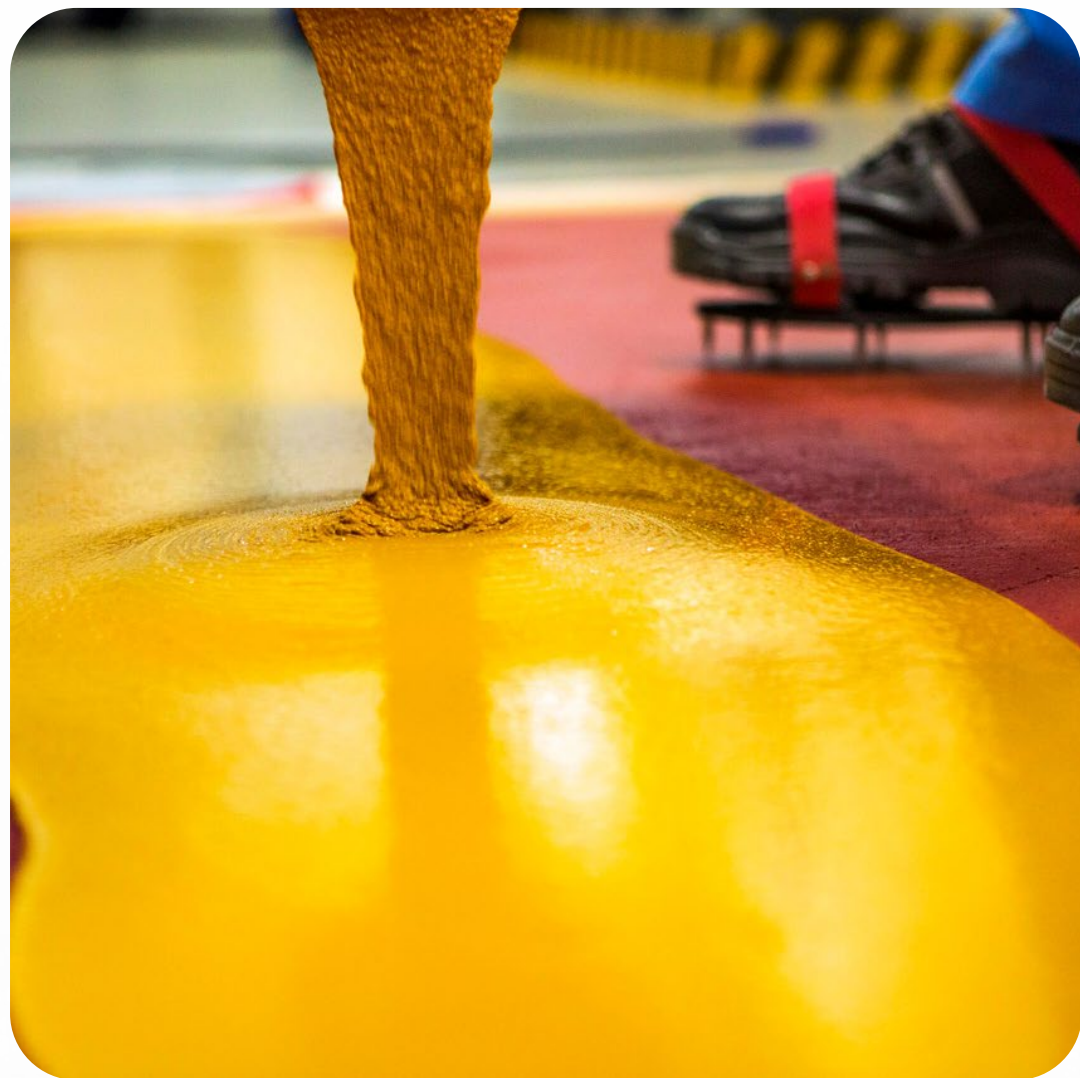

INDUSTRIAL FLOORING

Epoxy Screed Repair



INDUSTRIAL FLOORING

Bridge Painting



INDUSTRIAL FLOORING

Cementitious Material Coating

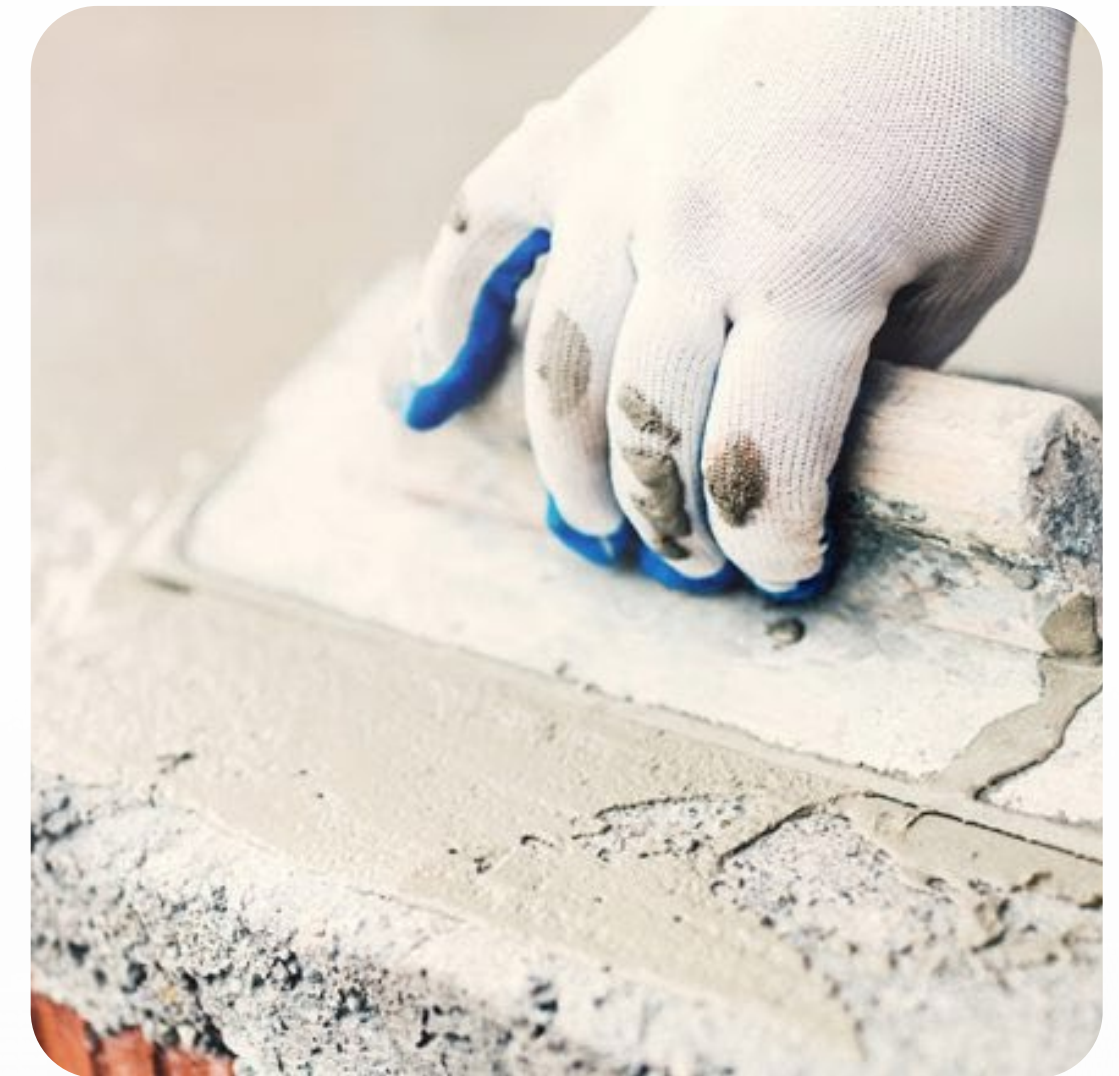
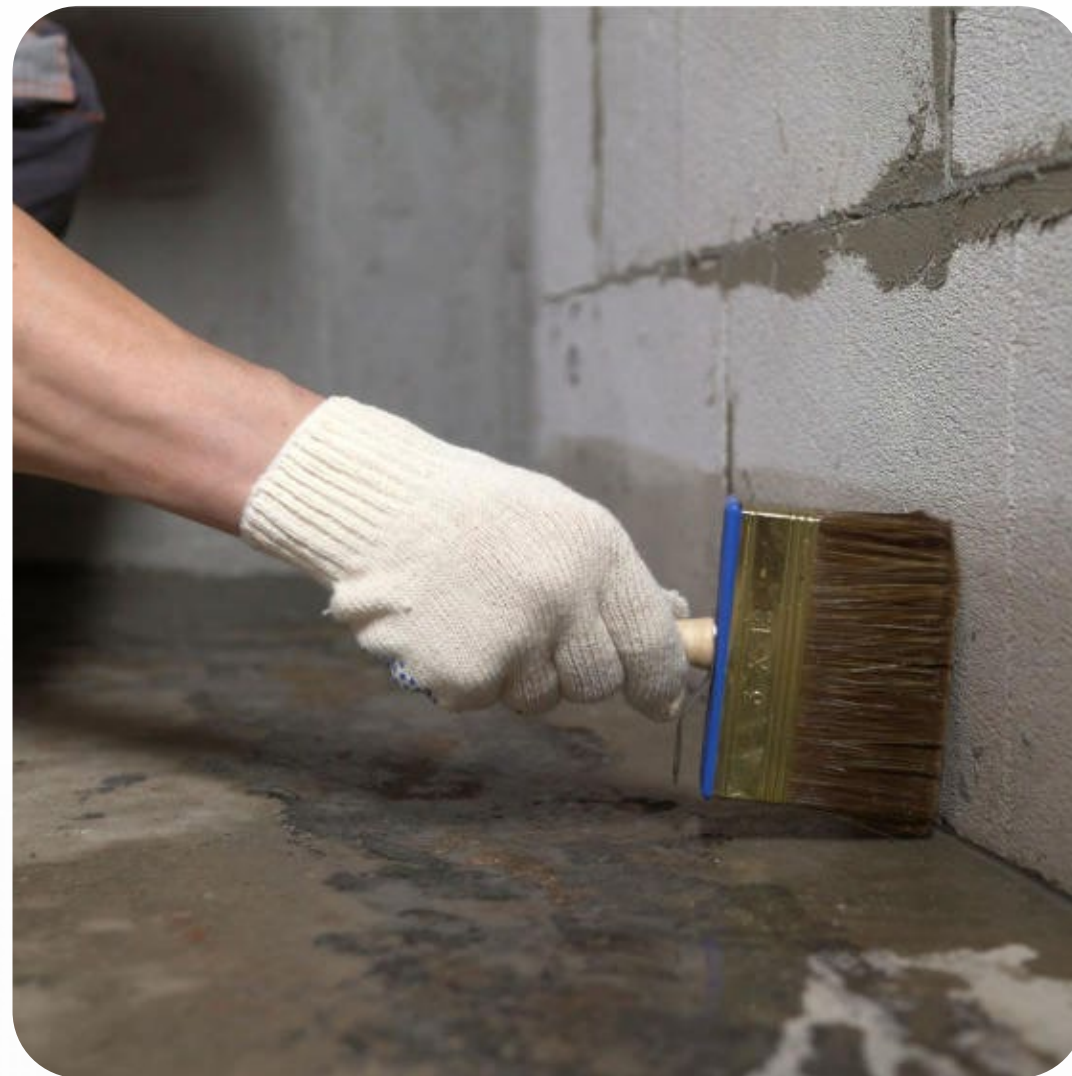

INDUSTRIAL FLOORING

Epoxy Self Leveling specially
for SCECO Buildings



INDUSTRIAL FLOORING

Floor Traffic Deck Coating



INDUSTRIAL FLOORING

Floor Epoxy Resin Coating



BRIDGE EXPANSION JOINT

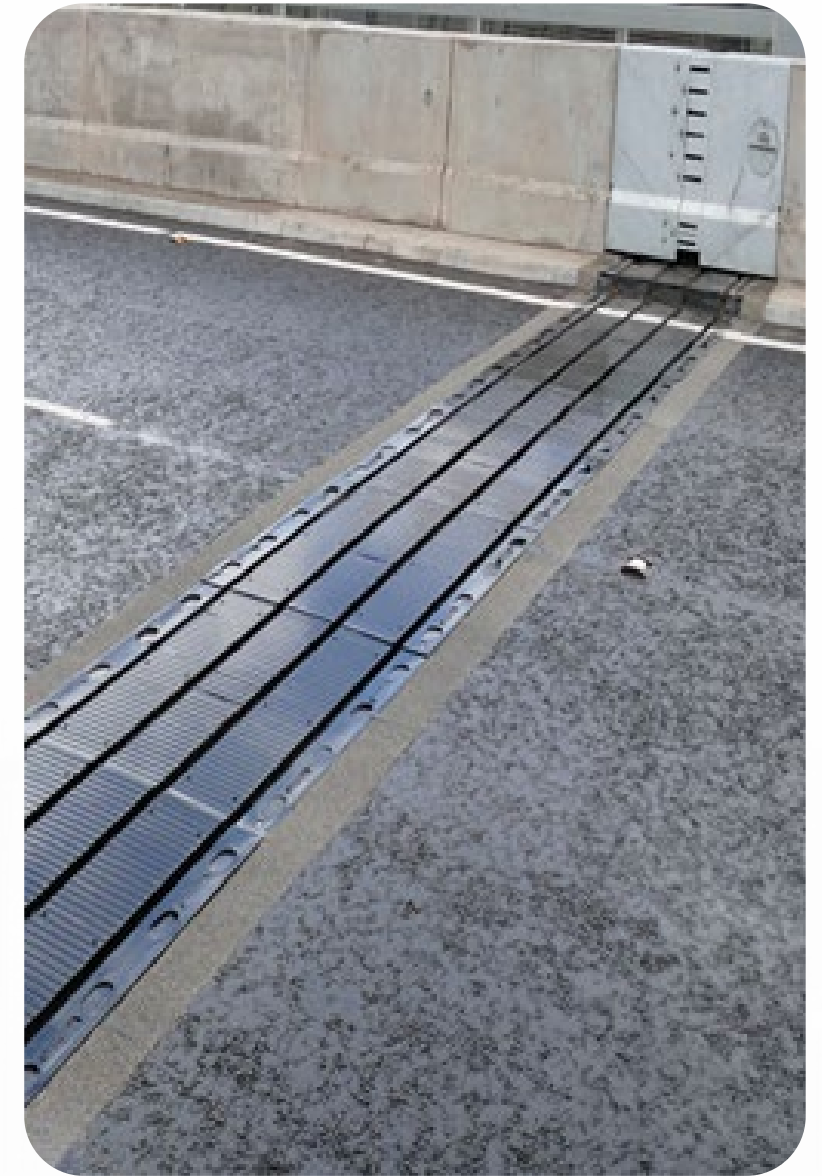



WATER PROOFING

PVC Waterproofing System



WATER PROOFING

PVC Waterproofing System



WATER PROOFING

PVC Waterproofing System



WATER PROOFING

PVC Waterproofing Membrane

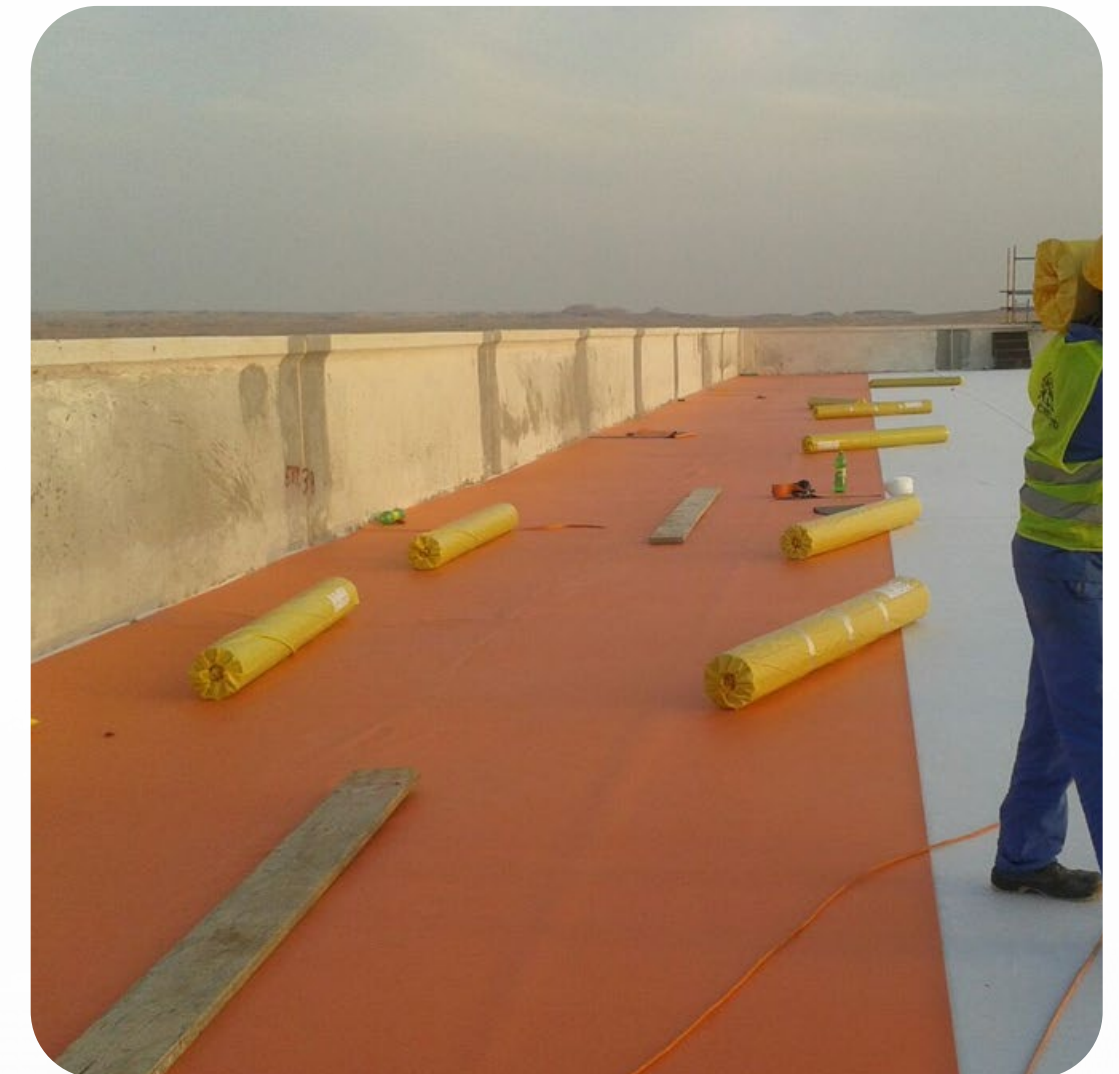

WATER PROOFING

Spray Polyurethane Foam

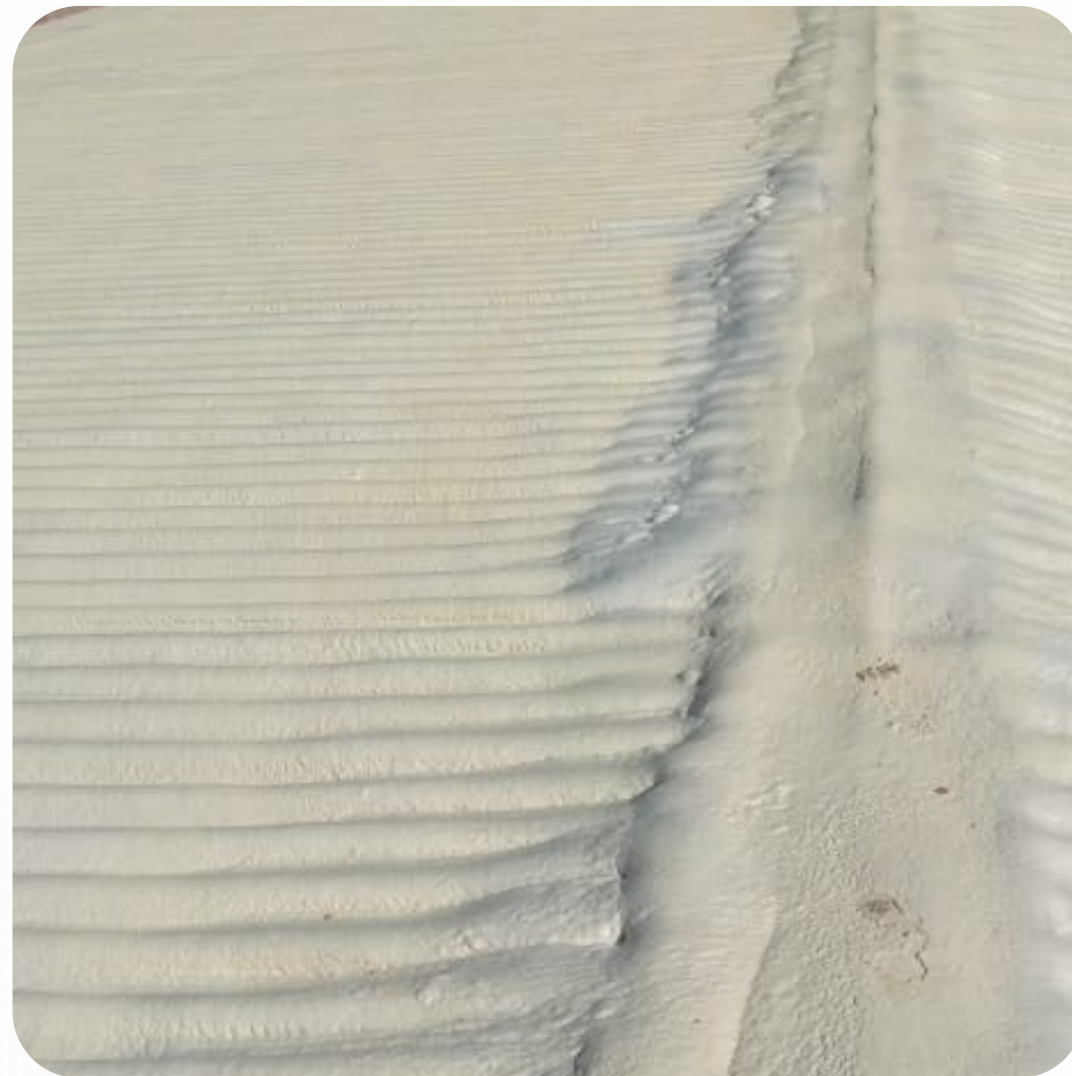

WATER PROOFING

Steel Tanks Epoxy
Polyurethane Coating



WATER PROOFING

Polyurethane Coating

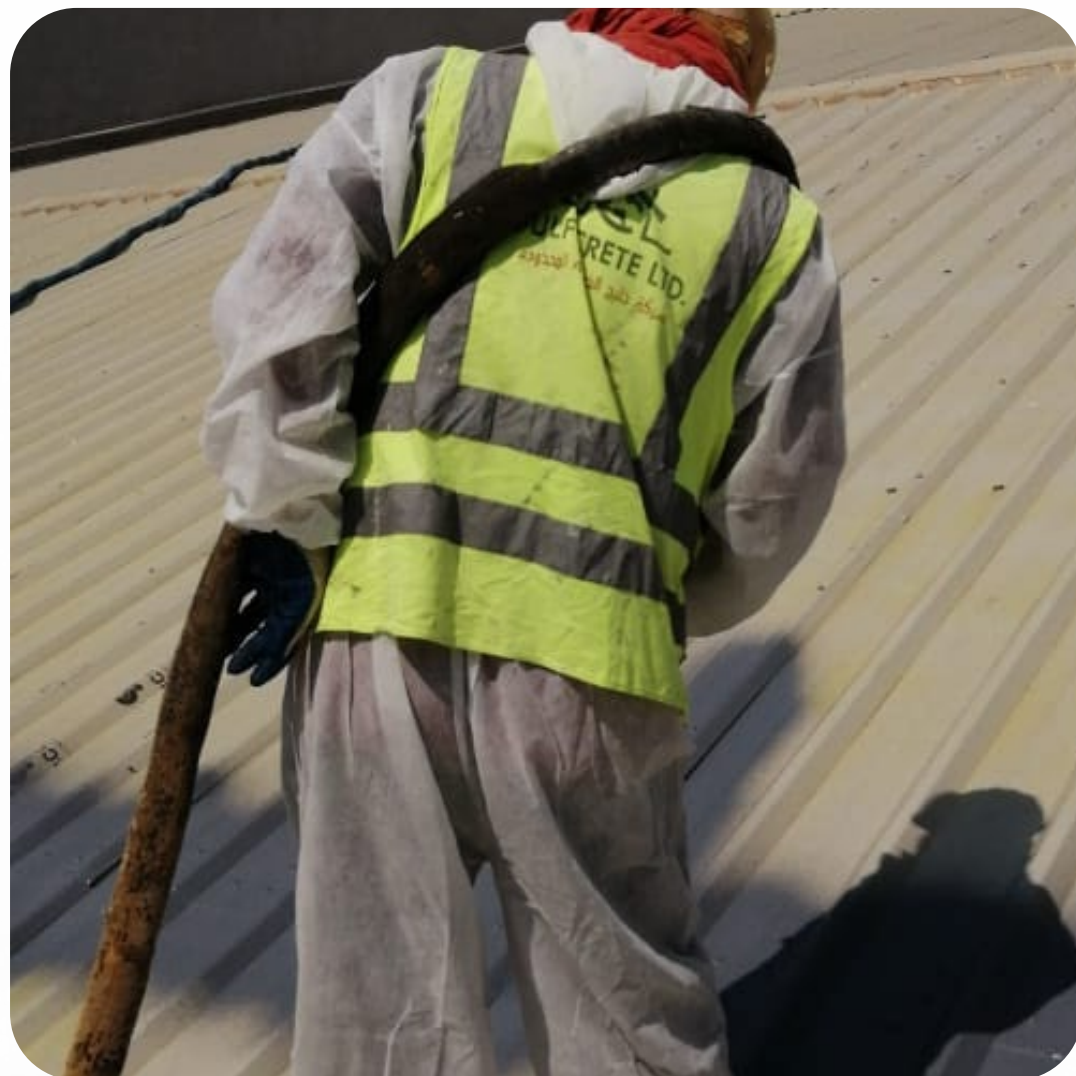

WATER PROOFING

Crystalline Coating

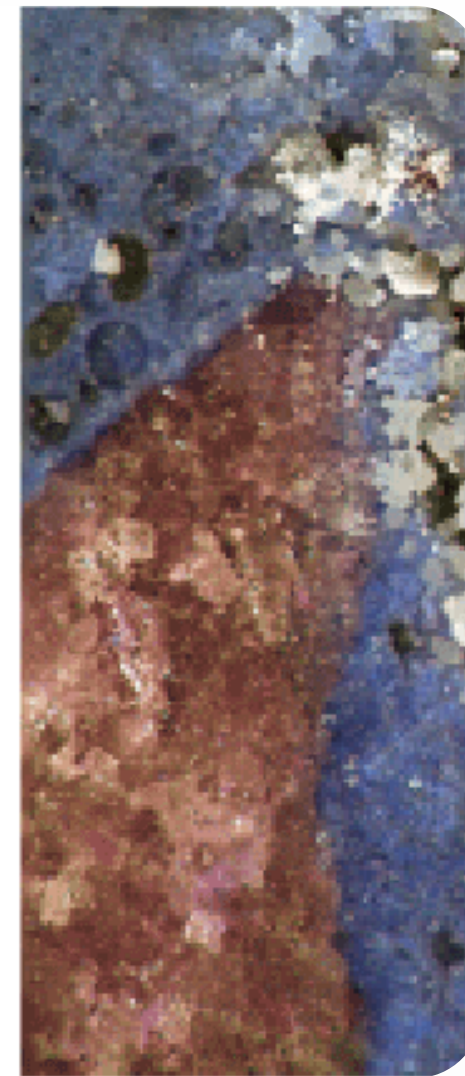

WATER PROOFING

Cementitious Coating

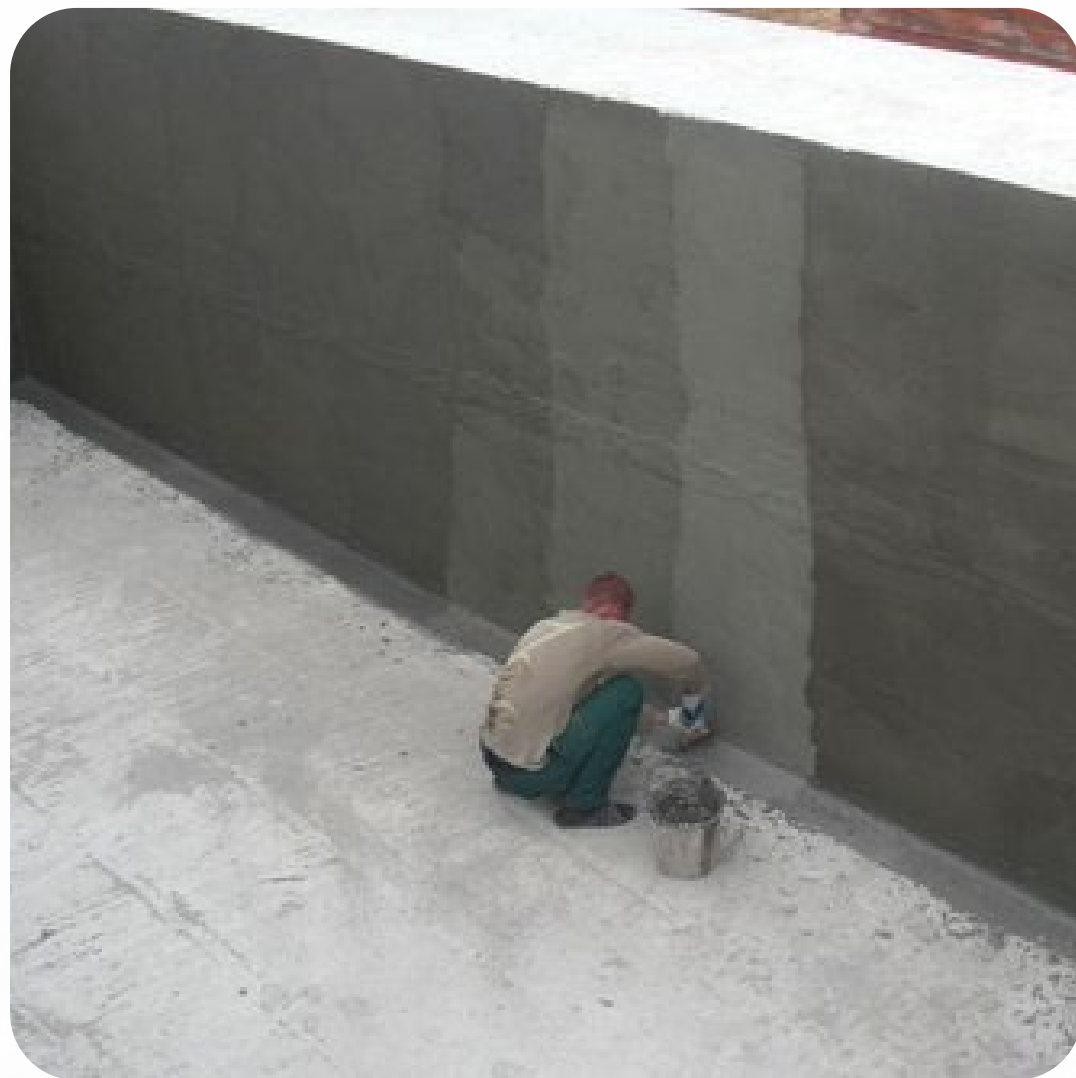

WATER PROOFING

Epoxy Coating



WATER PROOFING

TPO Waterproofing Membrane

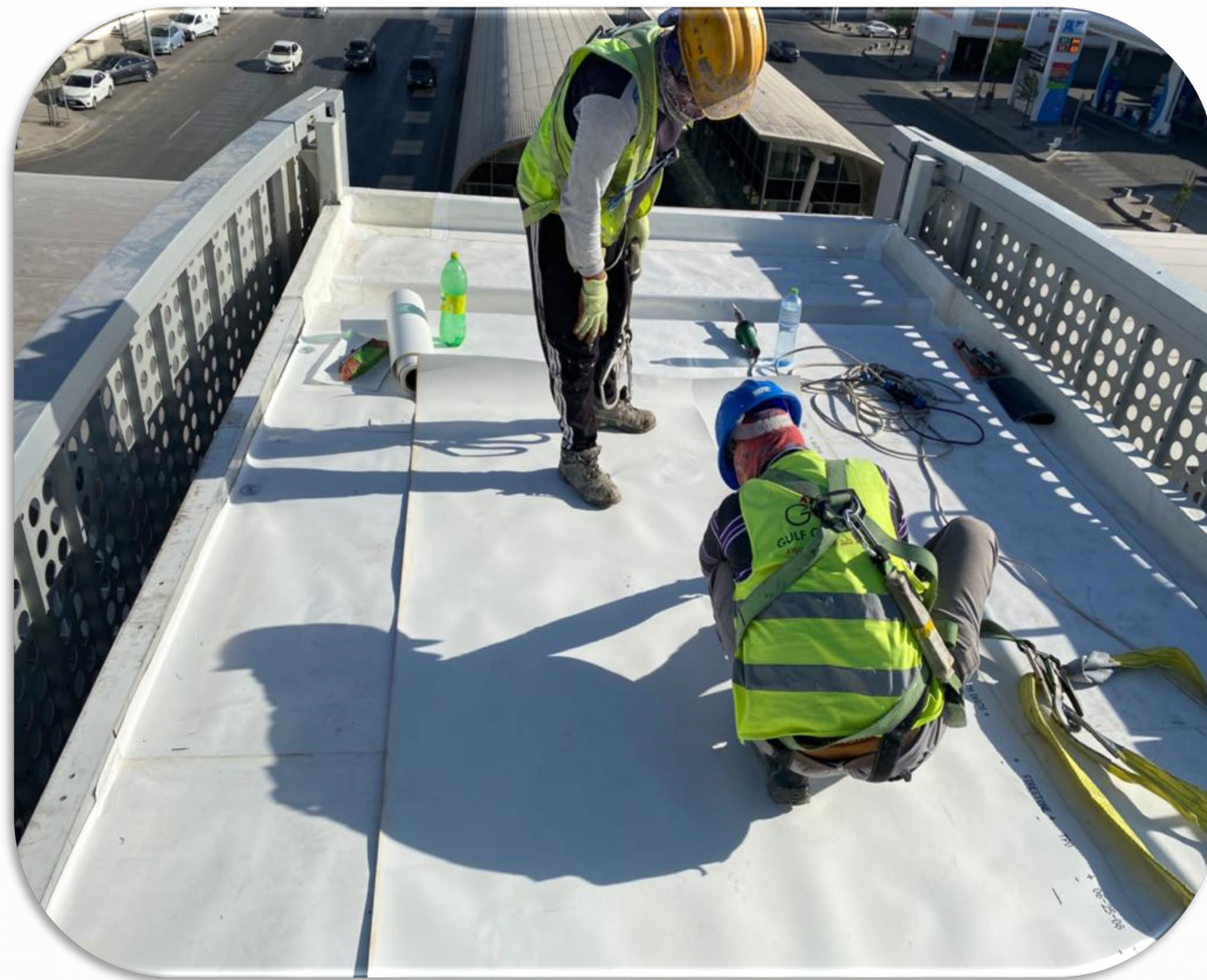

WATER PROOFING

TPO Waterproofing Membrane



WATER PROOFING

HDPE Waterproofing Membrane

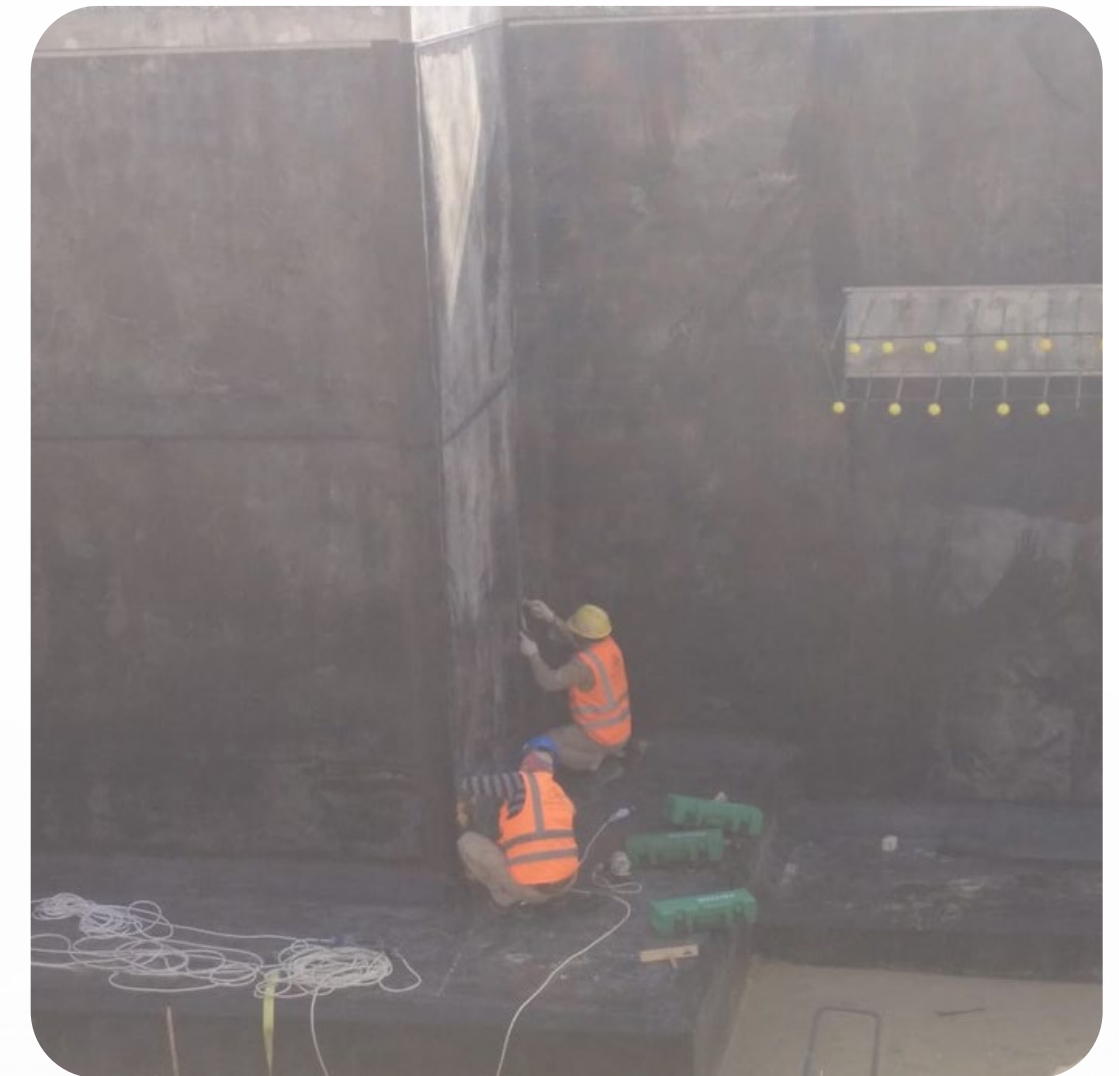
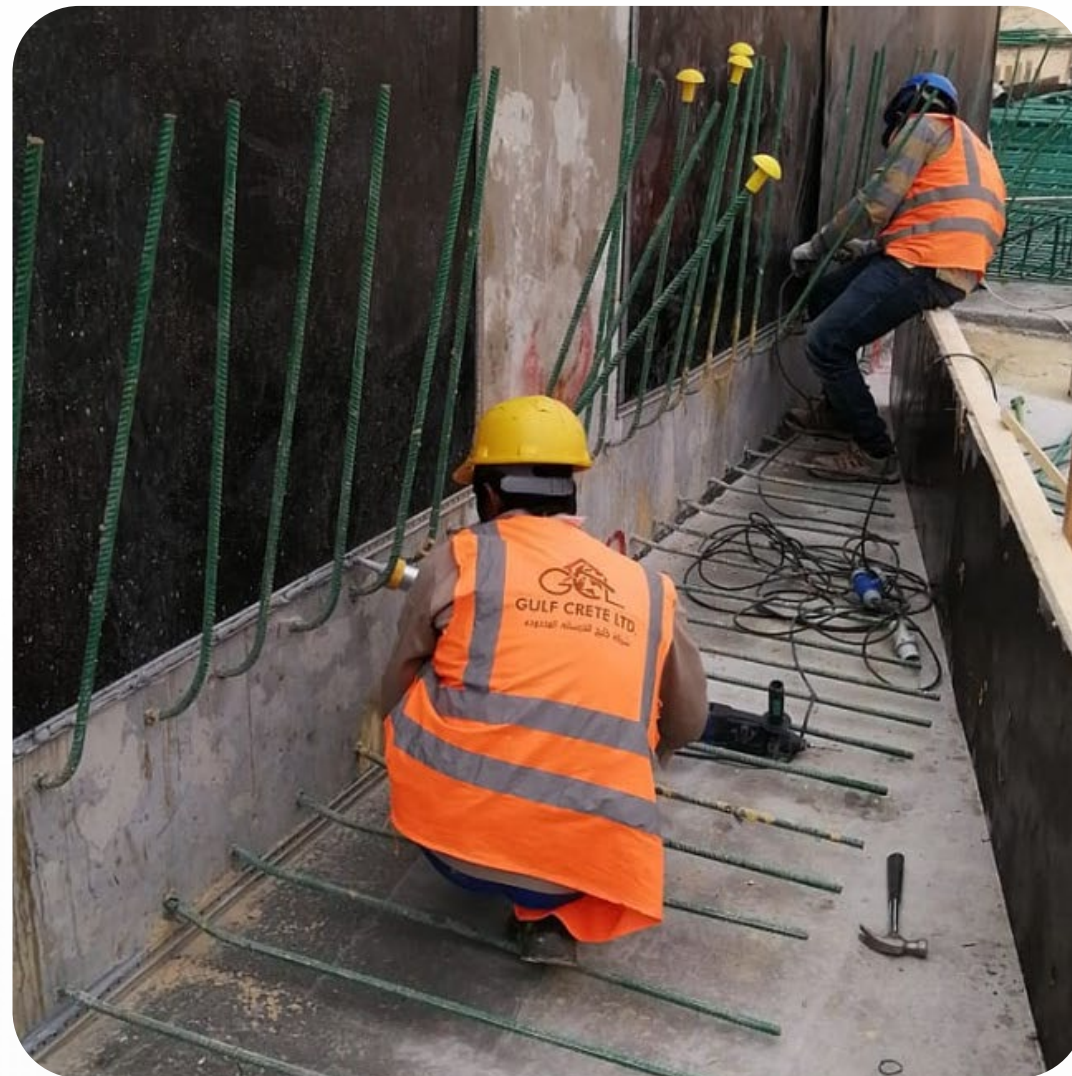

WATER PROOFING

EPDM Waterproofing Membrane

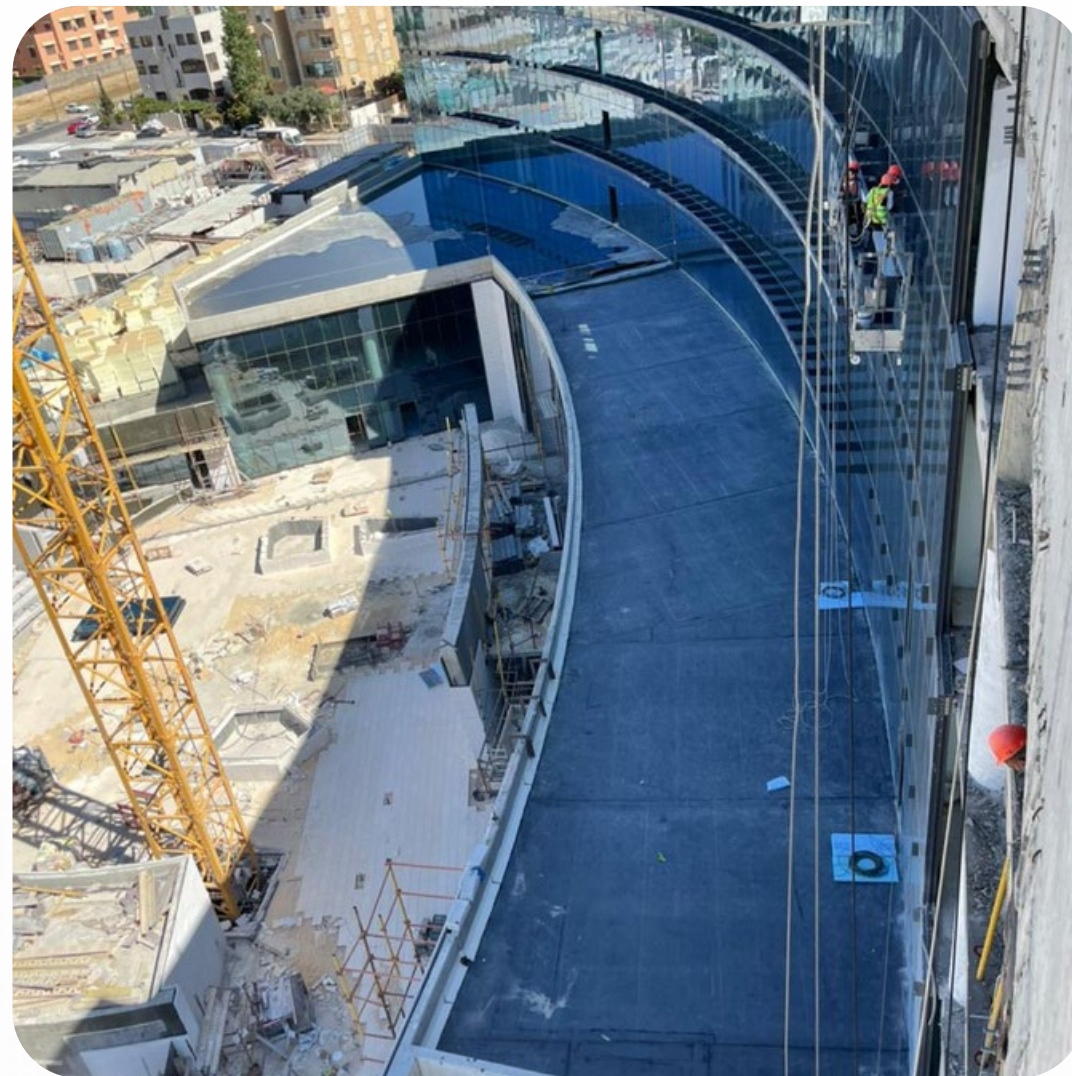

WATER PROOFING

Bituminiate Waterproofing



WATER PROOFING

Foam Concrete Work

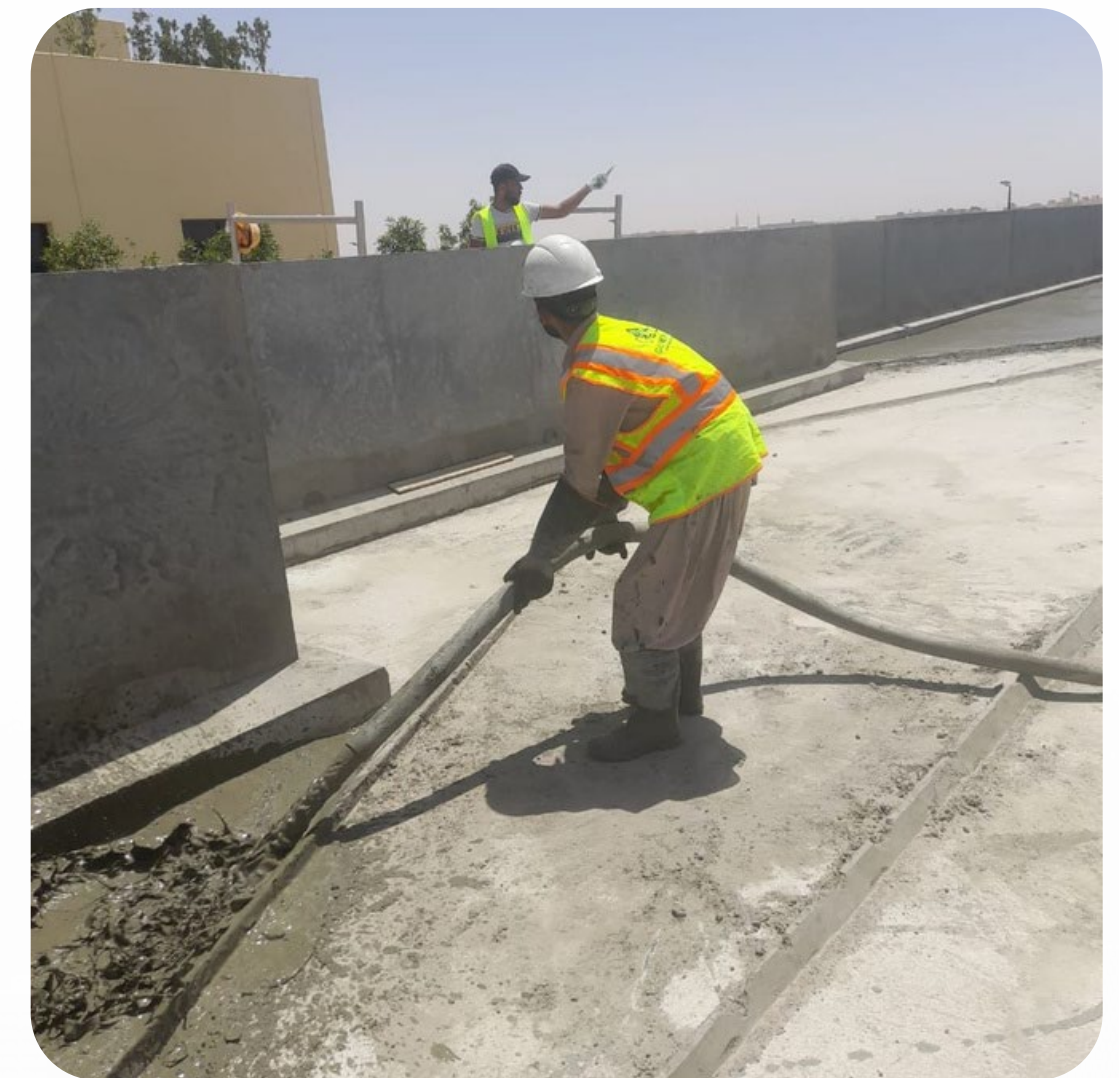

FIRE PROOFING

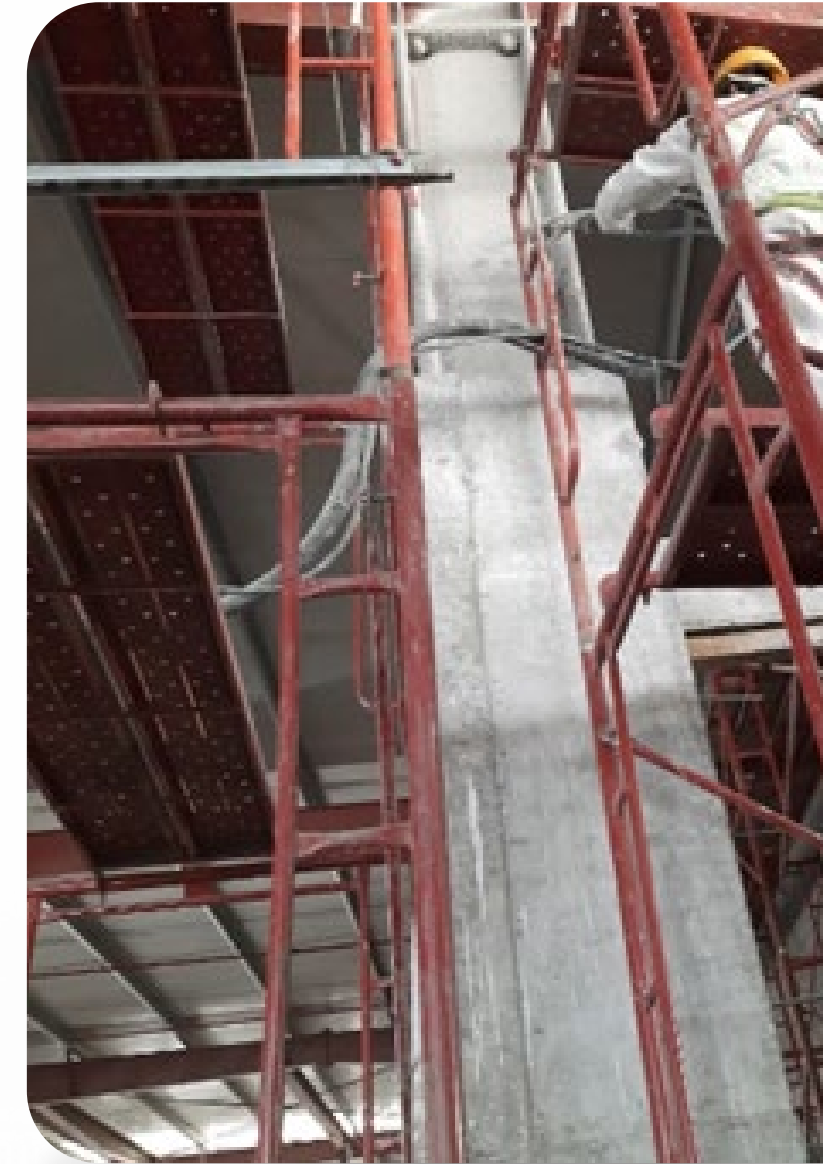
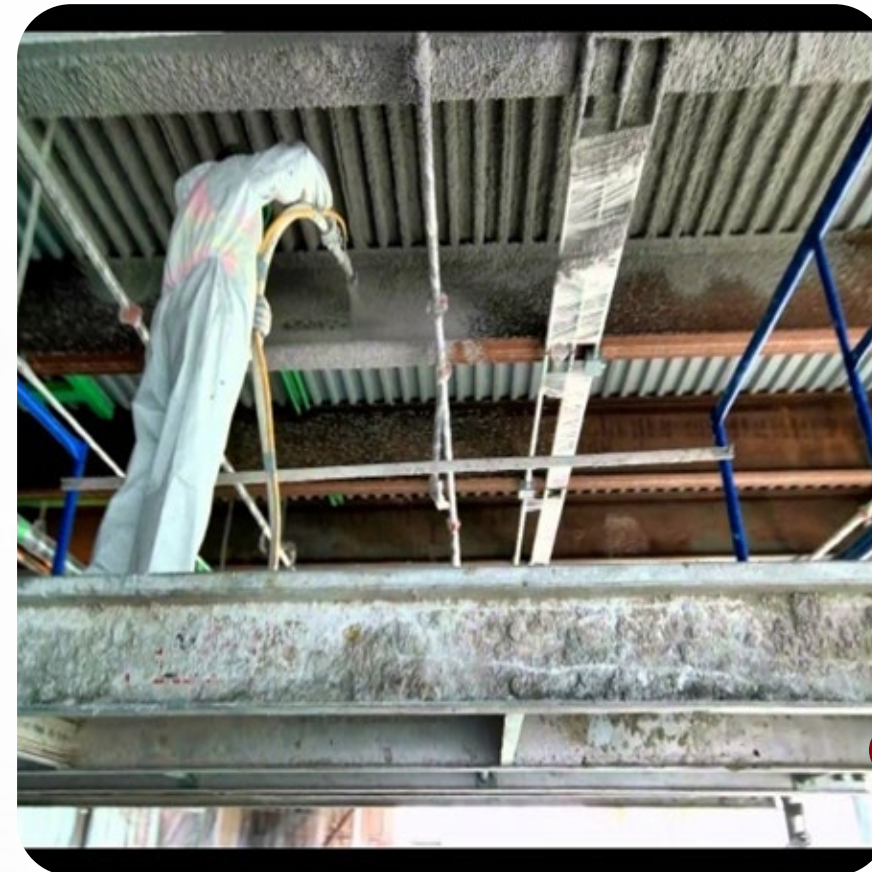
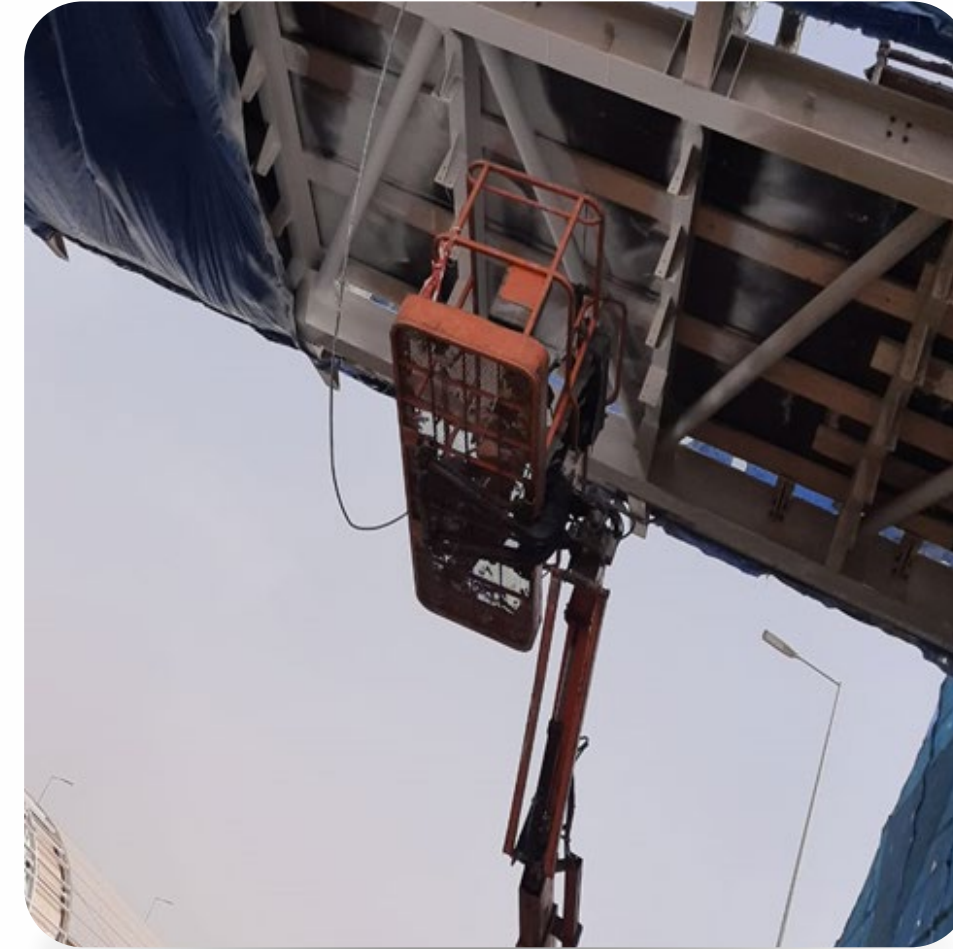

FIRE PROOFING

Cementitious Paint



FIRE PROOFING



Cementitious Paint



FIRE PROOFING

Intumescent Paint

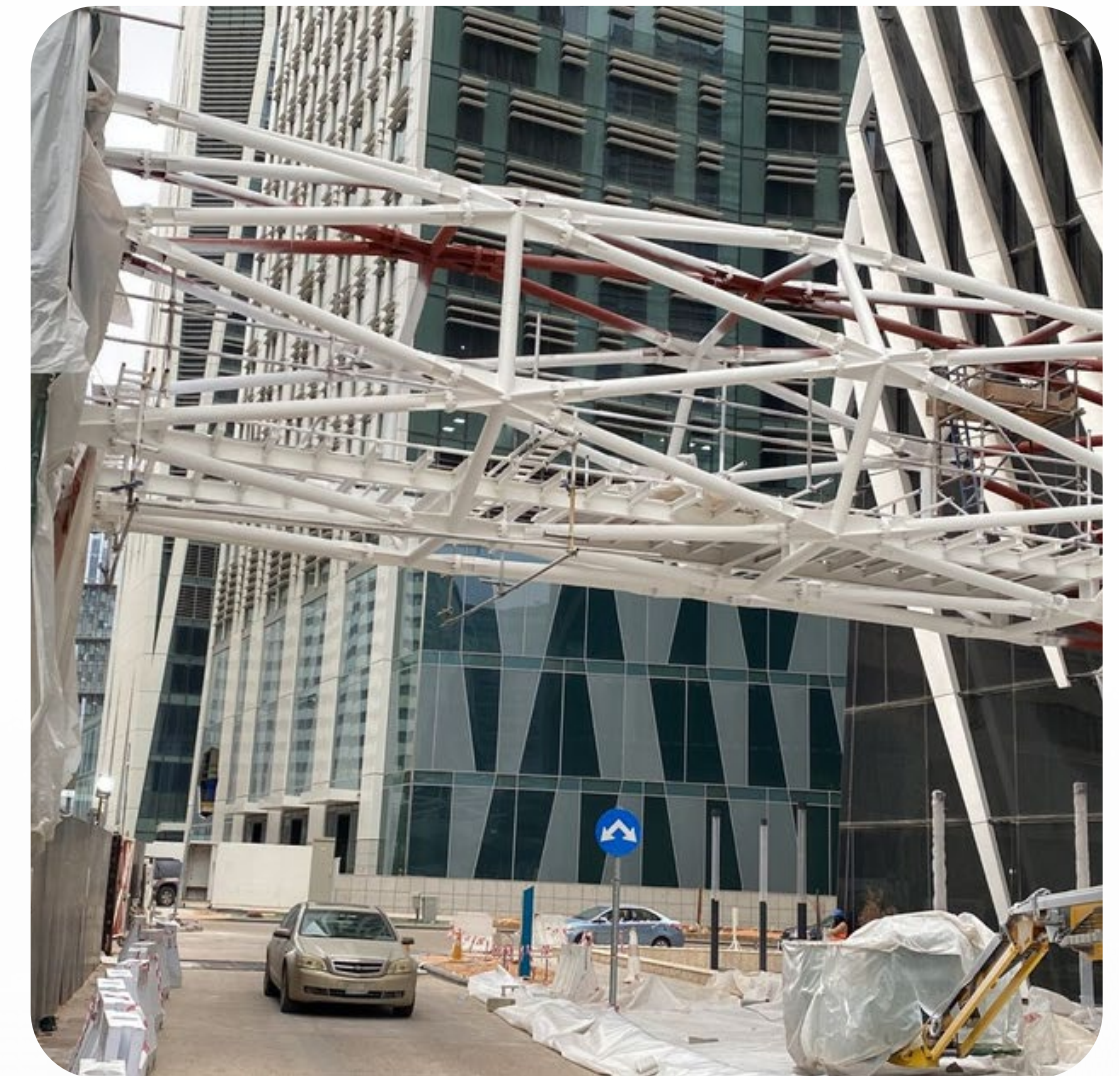
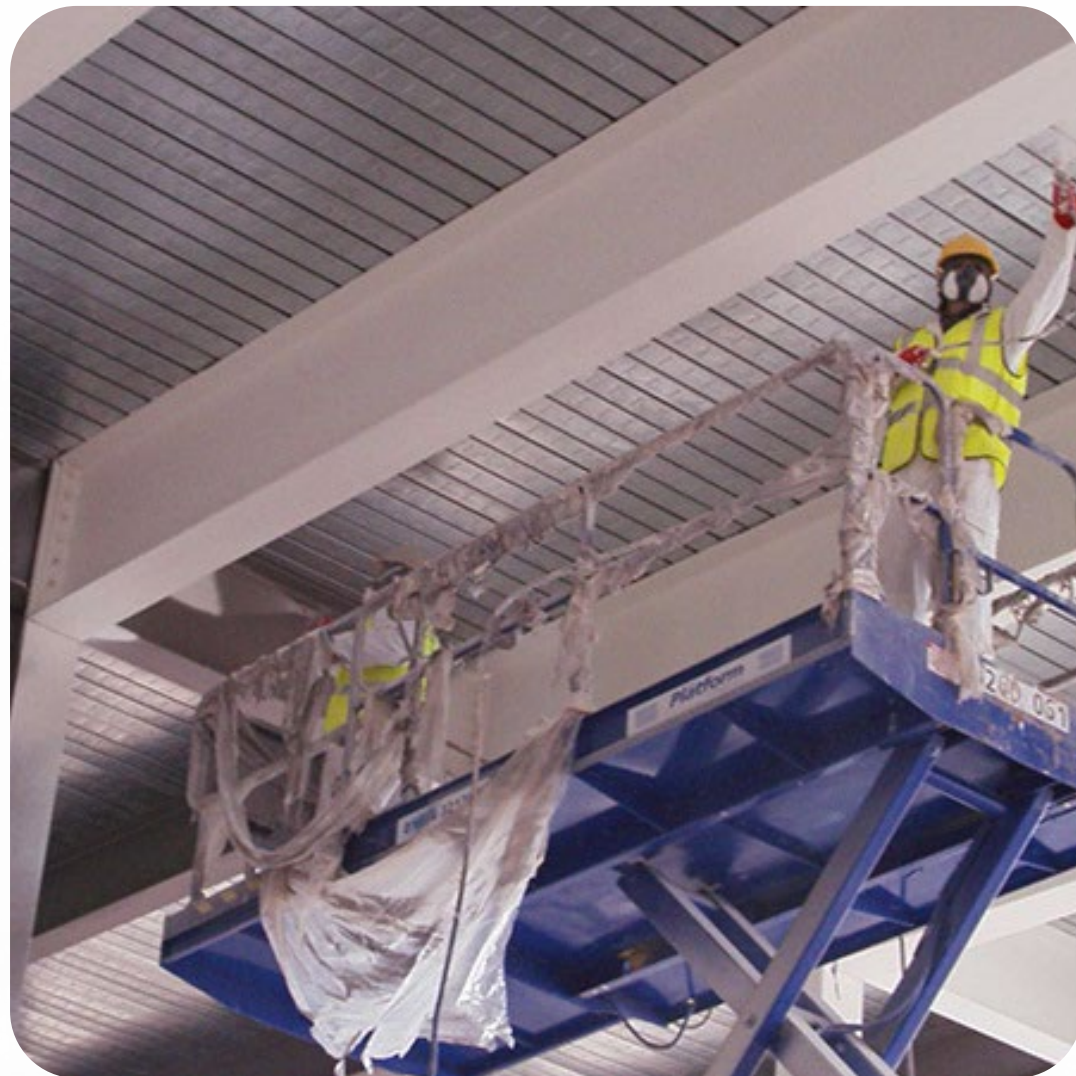

FIRE PROOFING

Intumescent Paint

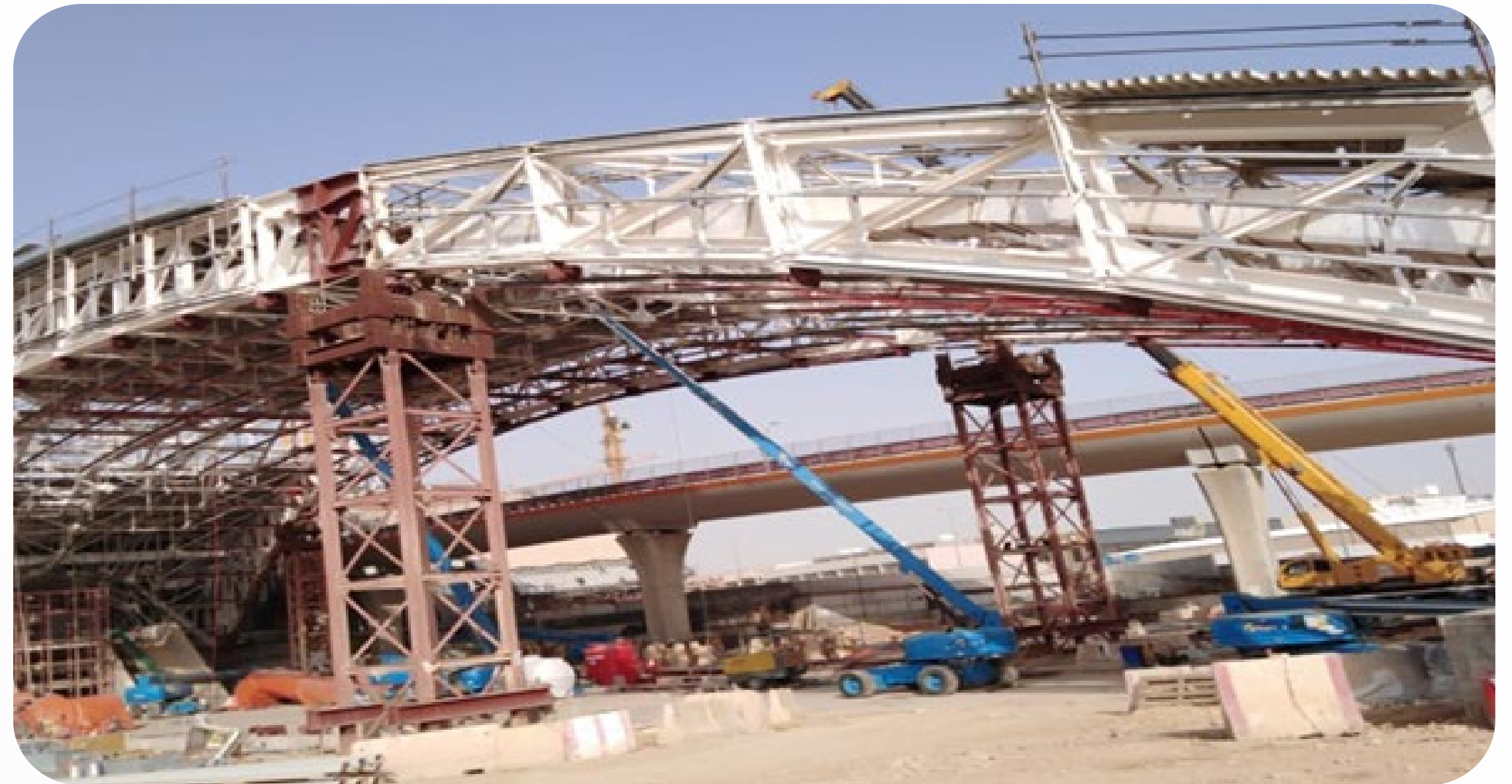

FITOUT

AND RENOVATION

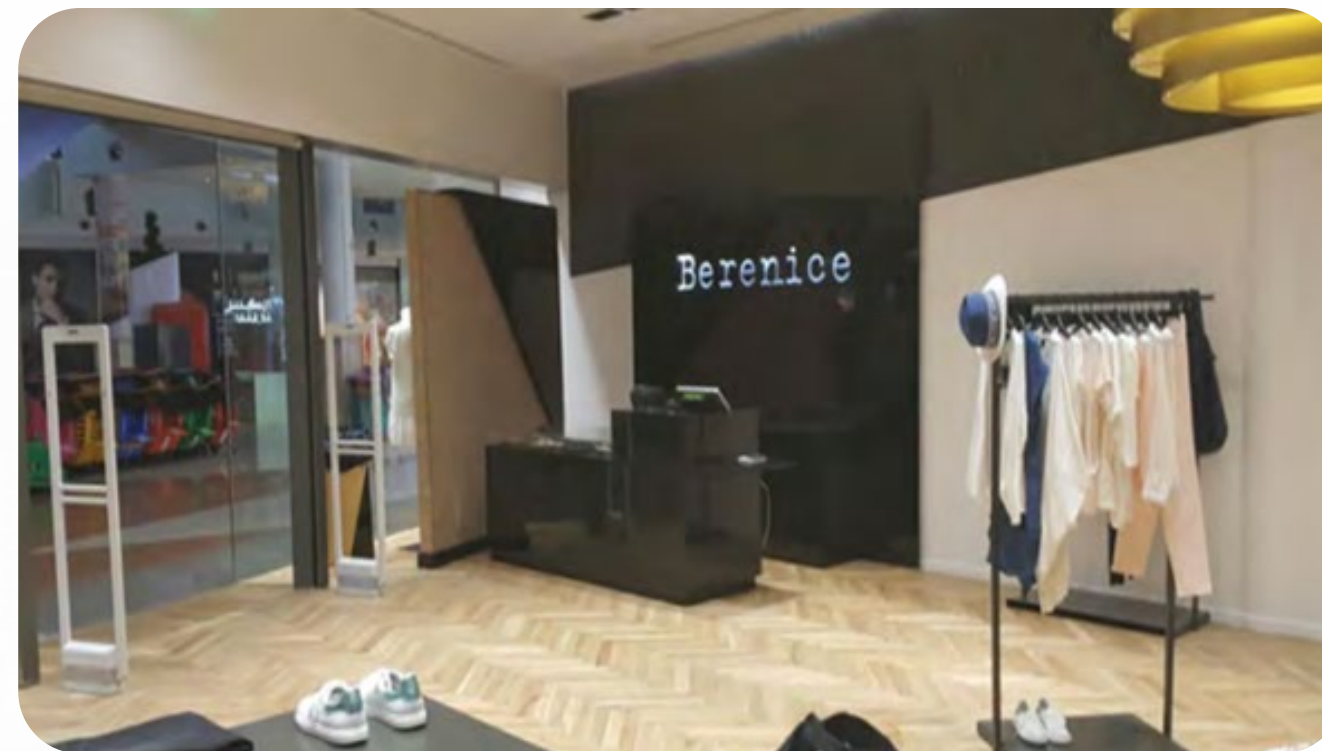

The background of the slide is a photograph of two hands shaking in a firm grip, symbolizing partnership or agreement. The hands are wearing dark blue pinstriped suit sleeves. The text is overlaid on a semi-transparent dark grey horizontal band.

PARTNERS & Suppliers

Our Partner & Suppliers





MAJOR PROJECTS



Water Proofing Projects

AREA	Work Scope	Status	Contract Amount - SAR
Riyadh	Bituminate Water Proofing Membrane (APP & SBS)	Ongoing	SAR 2,200,000
Ras Al Khair	Builtup Waterproofing	Ongoing	SAR 16,000,000
Riyadh	Crystalline Waterproofing	Ongoing	SAR 1,791,640
Qiddiya	Cut & Cover Tunnel Pvc Waterproofing	Ongoing	SAR 24,800,000
Neom	Tunnel Pvc Waterproofing	Ongoing	SAR 67,000,000
Saudi Arabian Baytur Construction Co.	Water Leakage Injection Work	Sales Order	SAR 294,400
National Water Company (NWC) شركة المياه الوطنية	Water Proofing & Repair System	Sales Order	SAR 1,501,833
Ansab General Contracting Company شركة انساب للمقاولات العامة	Water Proofing PVC	Sales Order	SAR 99,188
National Water Company	Water Proofing	Sales Order	SAR 287,960
Gulf Builder for Trading & Contracting Co	Water Proofing	Sales Order	SAR 329,598

AREA	Work Scope	Status	Contract Amount - SAR
Saudi Real Estate Infrastructure Co (Binyah) الشركة العقارية السعودية للبنية التحتية مساهمة عامة	Water Proofing	Sales Order	SAR 25,047
QOTTUF AL J AZERAH LLC	Water Proofing	Sales Order	SAR 11,196
Dorar Tammam Contracting Company (DTC)	Water Proofing	Sales Order	SAR 222,755
Al Yamama Company	Water Proofing	Sales Order	SAR 15,870
BBIAGC J V	Water Proofing	Sales Order	SAR 384
Arab Supply & Trading Co. (Astra Construction) الشركة (استرا للإنشاءات) العربية للتموين والتجارة	Water Proofing	Sales Order	SAR 45,889
Advanced Construction For Cont.Co	Water Proofing	Sales Order	SAR 20,700
AL Khonaini International Co.	Water Proofing	Sales Order	SAR 2,855,645
Al Yamama Company	Water Proofing	Sales Order	SAR 10,868
Archirodon Group	Water Proofing	Sales Order	SAR 1,416,589
AL-HADA Contracting	Water Proofing PVC	Sales Order	SAR 17,250
Development Works Co.	Water Proofing	Sales Order	SAR 1,134,120

AREA	Work Scope	Status	Contract Amount - SAR
Hadania Trading & Contracting Co.	Water Proofing PVC	Sales Order	SAR 54,527
Arab Supply & Trading Co. (Astra Construction) الشركة (استرا للإنشاءات) العربية للتموين والتجارة	Water Proofing	Sales Order	SAR 3,127,093
Arab Supply & Trading Co. (Astra Construction) الشركة (استرا للإنشاءات) العربية للتموين والتجارة	Water Proofing	Sales Order	SAR 293,431
Shapoorji Pallonji Mideast LLC شركة شابورجي بالونجي ميد إيست	Water Proofing	Sales Order	SAR 3,968,434
Arab Supply & Trading Co. (Astra Construction) الشركة (استرا للإنشاءات) العربية للتموين والتجارة	Water Proofing	Sales Order	SAR 1,427,827
Saudi Constructioners Ltd	Water Proofing	Sales Order	SAR 15,703,210
AL-HADA Contracting	Water Proofing PVC	Sales Order	SAR 179,330
TBC شركة تطوير المباني	Water Proofing	Sales Order	SAR 3,161,379
Khalifa A.Al-Mulhem Co.Ltd.,	Water Proofing	Sales Order	SAR 55,834
Saudi Constructioners Ltd	Water Proofing	Sales Order	SAR 3,823,276
Shibh Al Jazira Contracting Company (SAJCO)	Water Proofing	Sales Order	SAR 22,922,059

AREA	Work Scope	Status	Contract Amount - SAR
Saudi Constructioners Ltd	Water Proofing PVC / Bitum.	Sales Order	SAR 2,068,957
Branch of China Railway 18th Bureau Group Co.Ltd	Water Proofing / S.Adhesive	Sales Order	SAR 8,752,920
ACCIONA AGUA S.A SAUDI ARABIA CO.(JV) تضامن فرع شركة اكسيونا أجواس ايه وشركة الراشد للتجارة والمقاولات	Water Proofing	Sales Order	SAR 253,000
Al Yamama Company	Water Tank Epoxy	Sales Order	SAR 17,394
Al-Khobar	Waterproofing & Tank Coatings	Ongoing	SAR 2,000,000

AREA	Work Scope	Status	Contract Amount - SAR
Algurair / Riyadh Buss.	Water Proofing TPO.	Sales Order	SAR 5,068,957
Al Raqtan Factory	Water proofing TPO	Sales Order	SAR 6,752,920
Al Marai CPP3	Water Proofing TPO / PVC	Sales Order	SAR 3,253,000
Izdihar project	Waterproofing & Tank Coatings	Sales Order	SAR 2,17,394
Rawshan Project	Waterproofing & Tank Coatings	Ongoing	SAR 2,000,000

Coating & Protective System

AREA	Work Scope	Status	Contract Amount - SAR
Tareg Al-Jaafari Cont. Est.,	Coating & Protective System	Sales Order	SAR 3,500,000
Al Shaheen metal industries	Coating & Protective System	Sales Order	SAR 67,239
Khalifa A.Al-Mulhem Co.Ltd.,	Coating & Protective System	Sales Order	SAR 58,490
NESMA & MABANI - NAS JV شركة نسما وشركاهم للمقاولات وتحالف شركتي المباني مقاولون عامون والأنظمة المتقدمة	Coating & Protective System	Sales Order	SAR 1,128,125
NESMA & MABANI - NAS JV شركة نسما وشركاهم للمقاولات وتحالف شركتي المباني مقاولون عامون والأنظمة المتقدمة	Coating & Protective System	Sales Order	SAR 164,896
Fourth Milling Company MC4	Coating & Protective System	Sales Order	SAR 427,859
SEPCOIII Electric Power Construction Co.Ltd.Branch فرع شركة سيبكو اليكتريك باور 111 كونستراكتشن المحدودة	Epoxy Coating	Sales Order	SAR 28,000,000
Diriyah	Epoxy Flooring	Ongoing	SAR 1,927,202
Coating &	Coating &	Coating &	Coating &

AREA	Work Scope	Status	Contract Amount - SAR
Arab Supply & Trading Co. (Astra Construction) الشركة العربية للتموين والتجارة (استرا للانشاءات)	Floor Coating	Sales Order	SAR 546,250
Saudi Constructioneers Ltd	Floor Coating	Sales Order	SAR 162,495
Tareg Al-Jaafari Cont. Est.,	Floor Epoxy Coating	Sales Order	SAR 923,289
Khalifa A.Al-Mulhem Co.Ltd.,	Floor Epoxy Coating	Sales Order	SAR 80,428
NESMA & MABANI - NAS JV شركة نسما وشركاهم للمقاولات وتحالف شركتي المباني مقاولون عامون والأنظمة المتقدمة	Floor Epoxy Coating	Sales Order	SAR 248,800
NESMA & MABANI - NAS JV شركة نسما وشركاهم للمقاولات وتحالف شركتي المباني مقاولون عامون والأنظمة المتقدمة	Floor Epoxy Coating	Sales Order	SAR 38,243
Arab Supply & Trading Co. (Astra Construction) الشركة العربية للتموين والتجارة (للانشاءات)	Flooring	Sales Order	SAR 868,581
NESMA & MABANI - NAS JV شركة نسما وشركاهم للمقاولات وتحالف شركتي المباني مقاولون عامون والأنظمة المتقدمة	Floor Epoxy Coating	Sales Order	SAR 366,390
Khalifa A.Al-Mulhem Co.Ltd.,	Floor Coating	Sales Order	SAR 7,220,039

Rock Fall & Rock Bolt

AREA	Work Scope	Status	Contract Amount - SAR
Aqabat Al Salabat - Southren Region	Rock Fall Barrier / Netting / Shot crete	Sales Order	SAR 30,998,581
Neom / Audit 3	Rock Fall barrier	Sales Order	SAR 1,800,000
Neom / Audit 3 phase 2	Rock Fall barrier	Sales order	SAR 3,27,600
Salini Saudi Arabia	Rock Bolt	Sales Order	SAR 1,244,231
HAIF TRADING & CONTRACTING CO شركة هيف للتجارة والمقاولات	Rock Fall	Sales Order	SAR 24,837,240
China Railway Construction Co. LTD - Saudi	Rock Fall	Sales Order	SAR 1,117,800
Neom	Rockfall Protection / Shotcrete	Sales order	SAR 8,000,000

AREA	Work Scope	Status	Contract Amount - SAR
Aqabat Sinan	Rockfall Protection D&B	Sales order	SAR 80,000,000
Mofarreh Alharbi & Partners	Rockfall Protection System	Sales Order	SAR 402,500
Aqabat Thelle	Rockfall Protection&Shotcrete D&B	Sales order	SAR 7,000,000
Aqabat Dalah	Shot Crete	Sales Order	SAR 9,027,500
HAIF TRADING & CONTRACTING CO شركة هيف للتجارة والمقاولات	Shot Crete	Sales Order	SAR 4,600,000
Qiddiya	Shot Crete Works	Ongoing	SAR 4,600,000

Fireproofing

AREA	Work Scope	Status	Contract Amount - SAR
Saudi Arabian Baytur Construction Co.	Fireproofing	Sales Order	SAR 60,375
AGILITY Co.	Fireproofing	Sales Order	SAR 190,616
International Building Systems Factory Co. Ltd. (IBSF)	Fireproofing	Sales Order	SAR 765,511
Arail Construction & Industrial Co. LTD.	Fireproofing	Sales Order	SAR 1,709,893
Saudi Arabian Baytur Construction Co.	Fire proof	Sales Order	SAR 532,350
Development Works Co.	Fire Proof	Sales Order	SAR 1,812,285
Lulu Hayber market	Fire Proof	Sales Order	800,000.00
Western Station - 3B2	Fire Proof	Sales Order	SAR 17,812,285

Fireproofing

AREA	Work Scope	Status	Contract Amount - SAR
Riyadh Buss project	Fireproofing	Sales order	1,500,000
Riyadh Metro – 1F4	Fireproofing	Sales order	350,000.00
KAFD / Sky Bridge	Fireproofing	Sales order	984,000.00
KAFD / Steel building / SCC	Fireproofing	Sales Order	8000,000.00

Soil Injction & Maintenance Works

AREA	Work Scope	Status	Contract Amount - SAR
National Water Company (NWC) شركة المياه الوطنية	Maintenance Works	Sales Order	SAR 714,725
National Water Company (NWC) شركة المياه الوطنية	Maintenance Works	Sales Order	SAR 1,298,954
KING FAISAL SPECIALIST HOSPITAL & RESEARCH CENTER	Smart Flooring	Sales Order	SAR 2,617,791
Riyadh	Smart Flooring For Hospital	Ongoing	SAR 3,000,000
Al Babtain Contracting	Soil Enjction	Sales Order	SAR 112,386
Nizar Kurdi Al-Muhandis - نزار كردي للاستشارات الهندسيه	Soil Enjction	Sales Order	SAR 159,464
Abdul Ali Al Ajmi Company	Soil Enjction	Sales Order	SAR 14,950
Abdul Ali Al Ajmi Company	Soil Enjction	Sales Order	SAR 5,980

Structural Repair D&B

AREA	Work Scope	Status	Contract Amount - SAR
Umm Al-qura Cement	Strengthen Work	Sales Order	SAR 2,700,660
ARCHITECTS CONSTRUCTION	Strengthen Work	Sales Order	SAR 115,000
Al-Jubail	Structural Repairs	Sales order	SAR 11,000,000
Modern Arch MACC	Structural Strengthen & Repairing System	Sales Order	SAR 70,742
Khalifa A.Al-Mulhem Co.Ltd.,	Structural Strengthen & Repairing System	Sales Order	SAR 287,500
Taif	Strutural Repair D&B	Sales order	2.800,000
Qiddiya	Ongoing	Sales order	SAR 1,034,770
Arab Company for Laboratories & Soil لللمختبرات والتربة العربية	Supply Of Drilling Tools	Sales Order	SAR 6,900
KADF	Column Jacketing / & CFRP	Sales order	3,700,000.00

Structural Repair D&B

AREA	Work Scope	Status	Contract Amount - SAR
MOT SCHOOLS	CFRP	Sales Order	2,300,000.0
Bridges	CFRP / Concrete repair	Sales order	670,000.00
مجلس التعاون الخليجي	Concrete Footing Jackting	Sales order	800,000.00
NWC	Concrete Repair	Sales Order	1,200,000.00
STS / National Bank	Column Steel jacketing	Sales order	1,1340,000.00



APPROVAL

APPROVAL



ARAMCO

أرامكو السعودية
saudi aramco

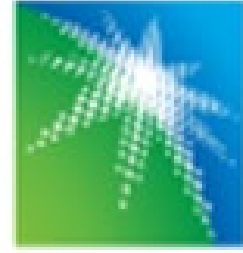

SABIC

سابك
عنطاك



SECOC

الشركة السعودية للكهرباء
Saudi Electricity Company
Diligently Serving You



شركة المياه الوطنية
National Water Company



NWC



R.C.J & Y



NESMA &
PARTNERS

Nesma نسما
& Partners وشركاهم



SWCC



المؤسسة العامة لتحلية المياه المالحة
Saline Water Conversion Corporation

APPROVAL

✓ BECHTEL



✓ El- SEIF



✓ D.U.N.S



✓ Al- Kha fji J o i n t
Op e r a t i o n



✓ TRSDC



✓ GACA





GOVERNMENT CERTIFICATION

Ministry of Commerce Certificate



رؤية 2030
VISION 2030
المملكة العربية السعودية
KINGDOM OF SAUDI ARABIA

شركة خليج الخرسانة المحدودة

السجل التجاري: 1010419075

MCgovSA
www.mc.gov.sa



رمزك التجاري QR Code

من خلاله يمكنك التحقق المباشر من المعلومات:

- السجل التجاري
- رخصة البلدية
- شهادة السعودة
- برنامج نطاقات
- شهادة الزكاة
- الغرفة التجارية

Ministry of Commerce Certificate



السادة/ شركة خليج الخرسانة المحدودة

نهنتكم بدخول عالم الأعمال التجارية وإصدار سجلكم التجاري، ونتطلع أن يساهم هذا السجل في تحقيق تطلعاتكم، وأن يكتب الله لكم التوفيق والنجاح في عملكم التجاري وأن تكون شريكاً في تعزيز اقتصاد المملكة العربية السعودية.
يسرنا إبلاغكم بأن رقم منشآتكم الموحد هو ٧٠٠١٨٥٦٦٥٢ وقد تم ربطه بالخدمات الحكومية التي ستحتاجها مستقبلاً. وهي على النحو التالي:

الرقم:	رقم سجلكم التجاري للمنشأة	وزارة التجارة Ministry of Commerce
١.١.٤١٩.٧٥	رقم منشآتكم لدى وزارة الموارد البشرية والتنمية الاجتماعية	وزارة الموارد البشرية والتنمية الاجتماعية Ministry of Human Resources Development
٣٨٨٩٧٥	تم تسجيل منشآتكم مجاناً لمدة سنة في خدمة واصل التجاري	سجل SPL
١.٢١٣٤٨٨١	رقم منشآتكم لدى هيئة الزكاة والضريبة والجمارك	هيئة الزكاة والضريبة والجمارك Zakat, Tax and Customs Authority
٣.١.٩٩١٧٤٣	رقم منشآتكم لدى المؤسسة العامة للتأمينات الاجتماعية	تحت الإجراء
٧٨٤٨٧	رقم منشآتكم لدى الغرفة التجارية.	الغرفة التجارية السعودية Publication of Saudi Chambers
يوجد أكثر من رخصة	رقم رخصة "بلدية" فورية (في حال اختياركم)	بلدية baldy



يُتيح تطبيق "نوافذ منشآت" العديد من الخدمات الممكنة لك في عالم الأعمال ومنها الحصول على الإرشاد والاستشارات، تطبيق "نوافذ منشآت" بوابة دخولك إلى عالم الأعمال، <https://www.monshaat.gov.sa/nawafth>



ويمكنك فتح حساب بنكي دون الحاجة إلى أي أختام لمنشآتكم

كما جمعنا لك كافة الأنظمة واللوائح بلغة بسيطة في دليل التاجر لتمارس عملك التجاري بسهولة mc.gov.sa/trader/guide

920000667 | الرياض 11162
Kingdom of Saudi Arabia | المملكة العربية السعودية

MCgovSA
www.mc.gov.sa

شهادة تسجيل الشركة Company Registration Certificate



الرقم الموحد: ٧٠٠١٨٥٦٦٥٢
رقم المنشأة: ١٠١٠٤١٩٠٧٥
التاريخ: ١٤٣٥/٠٩/٠٥ هـ

الاسم التجاري للشركة: شركة خليج الخرسانة المحدودة	نوعها: ذات مسئولية محدودة مختلطة	جنسيتها: سعودي
مدة الشركة: ٩٩ سنة	تبدأ من: ١٤٣٥/٠٩/٠٥ هـ	وتنتهي في: ١٥٣٧/٠٩/١٩ هـ
مركزها الرئيسي: ٤٥١٣,٧٠٦٠	الرمز البريدي: ١٢٢٨٢	ص. ب: ٢٠٦٤٧
هاتف: ١١٤٦٥٥٠٣٤	للاطلاع على بيانات الأنشطة الرجاء مسح الرمز التجاري	
رأس المال: ٥٠٠,٠٠٠ ريال سعودي	المديرون: 1: خالد ابراهيم محمد الشامخ	2: فتحي محمد رسمي عبدالفتاح الكوسا
	3:	4:
	5:	6:
	7:	8:
	9:	10:
	11:	12:
	13:	14:
	15:	16:
سلطات المدير/المديرون: حسب ما نص عليه عقد الشركة		
يشهد مكتب السجل التجاري بمدينة الرياض	بأنه تم تسجيل الشركة المذكورة أعلاه بمدينة الرياض	بموجب الإيصال رقم: ٢٩٨٥٤٤٨٣
وتنتهي صلاحية الشهادات في: ١٤٤٨/٠٨/٠٧ هـ	تاريخ: ١٤٤٣/١٠/٢٨ هـ	



To Verify The Information Of This Certificate Visit <http://mc.gov.sa> بمعلوماتكم التحقق من صحة هذه الشهادة بالدخول على
+966 11 294 4444 | الرياض 11162 | Kingdom of Saudi Arabia | المملكة العربية السعودية | www.mc.gov.sa MCgovSA @





*Saudi Construction Authority *Tax & Customs Authority



2/1



الدرجة الثانية

شهادة

تصنيف مقدمي خدمات المدن

تمنح وزارة الشؤون البلدية والقروية والإسكان شهادة تصنيف بالدرجة

للمنشأة شركة خليج الخرسانة المحدودة

للمنشأة



بيانات المنشأة	رقم السجل التجاري/ الترخيص	تاريخ إصدار السجل التجاري/ الترخيص	اسم مالك المنشأة	نوع المنشأة	جنسية المنشأة	رأس المال
	1010419075	02/07/2014	خالد ابراهيم محمد التمامح			4737785

بيانات شهادة التصنيف	رقم الشهادة	تاريخ الإصدار	حجم المنشأة	درجة التقييم الائتماني	درجة التقييم الفني
	20212138	09/08/2021		BBB	73.55

أنشطة شهادة التصنيف	القطاع	الأنشطة
	التشييد والبناء	الإنشاءات العامة للمباني السكنية، الإنشاءات العامة للمباني الغير السكنية، يشمل (المدارس، المستشفيات، الفنادق... الخ) إنشاء المطارات ومرافقها، الإنشاءات العامة للمباني الحكومية، إنشاءات المباني الجاهزة في المواقع، ترميمات المباني السكنية والغير سكنية، إنشاء الجسور والأنفاق، إصلاح وصيانة الطرق والشوارع والأرصفة ومستلزمات الطرق، إصلاح وصيانة الجسور والأنفاق، إصلاح وصيانة قنوات الري والسقي وأبراج تخزين المياه الرئيسية، إصلاح وصيانة محطات ومشاريع الصرف الصحي وشبكات المجاري والمضخات، إصلاح وصيانة محطات وأبراج الاتصالات السلكية واللاسلكية والرادار، إنشاء وإقامة محطات وأبراج الاتصالات السلكية واللاسلكية والرادار، إنشاء أرصفة الموانئ والمرافق البحرية، إنشاء الموانئ والمراسي السياحية (المارينا)

وكيل الوزارة لتنظيم مشغلي المدن

م. فيصل بن حسين الصنقر

- يسري مفعول هذه الشهادة حتى تاريخ 09/08/2025
- تصدر هذه الشهادة إلكترونياً وعلى الجهات المالكة للمشاريع التحقق من الشهادة المقدمة من خلال موقع الوزارة.



2/2

الدرجة الثانية

ملحق الشهادة



شركة خليج الخرسانة المحدودة

اسم المنشأة

1010419075

رقم السجل التجاري / الترخيص

الأنشطة	القطاع	أنشطة شهادة التصنيف
تركيب وإصلاح وصيانة الابواب الاوتوماتيكية، تركيب وإصلاح وصيانة أنظمة التنظيف المركزية، تركيب وإصلاح وصيانة أنظمة العوازل الحرارية والمائية، تشطيب المباني، تركيب الابواب والشبابيك وإطارات الابواب (الشرشوب) والدريزونات والسلالم والمطابخ الخشبية، تركيب المظلات والسواتر، تركيب السيراميك والكاشي، تركيب الرخام، جلي وتلميع البلاط والرخام، تغطية الارضيات خشب الباركيه، تغطية الارضيات بالمطاط والمشمع واليلاستيك، أعمال وتركيب الديكورات المختلفة، أعمال التزيين ولصق ورق الحائط، أعمال التجصيص والمساح، أعمال الدهانات والطلاء للمباني الداخلية والخارجية، أعمال الدهانات والطلاء لهيكل الهندسة الحديثة، تركيب الزجاج والمرابا للمباني، تركيب زجاج واجهات الابراج، تنظيف المباني الجديدة بعد الإنشاء، التركيبات الداخلية للمحلات والمباني المتحركة والقوارب، أعمال تركيب الطابوق، أعمال تركيب الصخور، إنشاء حمامات السباحة، تنظيف المباني بالبخار وتسخين الرمل إنشاء السدود، تنظيف الممرات المائية، إنشاء كاسرات الأمواج والحماية للأرصيف، اعداد وتجهيز المواقع من الحفر والتسوية، صب القواعد والاساسات، سحب المياه الجوفية وتجفيف المواقع، القطع الصخري باستخدام المواد المنفجرة، تركيب وصيانة أجهزة ومعدات الإنذار من الحريق، تركيب وصيانة الأجهزة الأمنية، تركيب وصيانة أجهزة السلامة المرورية، تركيب شبكات الطاقة الشمسية وصيانتها وإصلاحها، تركيب وإصلاح وصيانة أنظمة العوازل الحرارية والمائية، تشطيب المباني، أعمال الدهانات والطلاء للمباني الداخلية والخارجية، أعمال الدهانات والطلاء لهيكل الهندسة الحديثة، أعمال تركيب الصخور	التشييد والبناء	أنشطة شهادة التصنيف

وكيل الوزارة لتنظيم مشغلي المدن

م. فيصل بن حسين الصقار

- يسري مفعول هذه الشهادة حتى تاريخ 09/08/2025

- تصدر هذه الشهادة إلكترونياً وعلى الجهات المالكة للمشاريع التحقق من الشهادة المقدمة من خلال موقع الوزارة.



Saudi VAT Registration Certification

100191004857715

تاريخ الإصدار: 2019/01/22
الرقم المميز: 3010991743

الهيئة العامة للزكاة والدخل
General Authority of Zakat & Tax

ضريبة القيمة المضافة
VAT

شهادة تسجيل في ضريبة القيمة المضافة
VAT Registration Certificate

تشهد الهيئة العامة للزكاة والدخل بأن المكلّف أدناه مسجل في ضريبة القيمة المضافة بتاريخ 2017/08/24

Hereby, The General Authority of Zakat & Tax (GAZT) certifies that the taxpayer below is VAT registered on 24/08/2017

اسم المكلّف: شركة خليج الخرسانة المحدودة
Taxpayer Name:

رقم التسجيل الضريبي: 301099174300003
VAT Registration Number:

تاريخ نفاذ التسجيل: 2018/01/01
Effective Registration Date:

عنوان المكلّف: الرياض، الورود، ابن مطير الحكمي، 11323
Taxpayer Address:

كمكّلف مسجل في ضريبة القيمة المضافة، لا يجوز لك تحصيل ضريبة القيمة المضافة من عملائك قبل تاريخ نفاذ التسجيل بالضريبة. في حال تبين غير ذلك، ستقوم الهيئة العامة للزكاة والدخل بتنفيذ الغرامات المستحقة

هذه الوثيقة مرسلة من النظام الآلي ولا تحتاج إلى توقيع
- الهيئة العامة للزكاة والدخل -

100191004857715

تاريخ الإصدار: 2019/01/22
الرقم المميز: 3010991743

الهيئة العامة للزكاة والدخل
General Authority of Zakat & Tax

ضريبة القيمة المضافة
VAT

اسم المكلّف: شركة خليج الخرسانة المحدودة
Taxpayer Name:

رقم السجل التجاري/الرخصة/العقد: 1010419075
CR / License / Contract No.:

الفترة الضريبية: ربع سنوي-Quarterly
Tax Period:

تاريخ استحقاق أول إقرار ضريبي: 2018/04/30
First Filing due date:

كمكّلف مسجل في ضريبة القيمة المضافة، لا يجوز لك تحصيل ضريبة القيمة المضافة من عملائك قبل تاريخ نفاذ التسجيل بالضريبة. في حال تبين غير ذلك، ستقوم الهيئة العامة للزكاة والدخل بتنفيذ الغرامات المستحقة

هذه الوثيقة مرسلة من النظام الآلي ولا تحتاج إلى توقيع
- الهيئة العامة للزكاة والدخل -

*General Organization for Social Insurance * Human Resources Certification

رؤية
2030
المملكة العربية السعودية
KINGDOM OF SAUDI ARABIA

الموارد البشرية
والتنمية الاجتماعية

شهادة سعودة

رقم الشهادة 188139-20764358

تاريخ الإصدار 2023-03-13

تاريخ الانتهاء 2023-09-24

تاريخ التجديد 2023-06-26

رقم المنشأة 1-388975

اسم المنشأة شركة خليج الخرسانة المحدودة

حالة الشهادة نشط

رقم السجل التجاري 1010419075

الرقم الوطني الموحد 7001856652



تشهد وزارة الموارد البشرية والتنمية الاجتماعية بأن المنشأة المذكورة أعلاه حققت نسب التوطين المطلوبة منها

وتم منحها هذه الشهادة حسب طلبها

الشهادة معتمدة من صاحب الصلاحية ولا تحتاج إلى توقيع أو ختم



المؤسسة العامة للتأمينات الاجتماعية
General Organization for Social Insurance

التاريخ ١٤٤٤/١٢/٠٨
الموافق ٢٦/٠٦/٢٠٢٣
رمز الشهادة ٥٥٥٦٣٥٤٣

شهادة

إسم المنشأة : شركة خليج الخرسانة المحدودة

الرياض
السعودية

رقم الإشتراك : ٥٠٨١٨٥٦٧٧
رقم السجل التجاري: ١٠١٠٤١٩٠٧٥
مصدره :

رقما	كتابة
٢٦	ستة و عشرون مشتركا
١٤٦	مائة و ستة و اربعون مشتركا
١٧٢	مائة و اثنان و سبعون مشتركا

عدد المشتركين السعوديين
عدد المشتركين غير السعوديين
المجموع

تشهد المؤسسة العامة للتأمينات الاجتماعية بأن المنشأة المذكورة أعلاه قد أوفت بالتزاماتها تجاه المؤسسة وفق البيانات المقدمة منها حتى تاريخ إصدار هذه الشهادة ، والتي تم منحها لتقدمها لأية جهة تطلبها ، وهي صالحة لجميع الأغراض التي نص عليها نظام التأمينات الاجتماعية في المادة (١٩/٦) منه.

هذه الشهادة سارية المفعول حتى ١٤٤٥/٠١/٠٧ هـ.

يلزم التحقق من صحة وصلاحية الشهادة عبر زيارة الرابط أدناه في الموقع الإلكتروني للمؤسسة العامة للتأمينات الاجتماعية أو عن طريق استخدام الرمز المعرف التالي :



www.gosi.gov.sa/vc

(الشهادة معتمدة من صاحب الصلاحية ولا تحتاج إلى توقيع أو ختم)

www.gosi.gov.sa
800 1243344



التأمينات الإلكترونية
برمحاتك من محلات

تعد هذه الشهادة من الوثائق الإلكترونية الحكومية الرسمية ، ويحظر قطعها تقليدها أو إدخال أي تعديلات عليها سواء بالإضافة أو الحذف أو التغيير في بياناتها أو غير ذلك من أنواع التعديل ، وتعد الشهادة لاغية إذا شليها شيء من ذلك ، كما تعرض صاحبها للملاحقة النظامية أمام الجهات المختصة بالإضافة إلى مايفرضه نظام التأمينات الاجتماعية من عقوبات ، وللاجوز تداول الشهادة إلا في الأغراض التي أصدرت لأجلها وفقا لأحكام نظام التأمينات الاجتماعية ، والمؤسسة العامة للتأمينات الاجتماعية غير مسؤولة عن أي آثار أخرى مترتبة قبل الغير عن الشهادة وغير مسؤولة عن أي عملية تزوير أو تعديل تتم على البيانات الواردة فيها .

Riyadh Membership Certification



شهادة اشتراك Membership Certificate

غرفة الرياض
Riyadh Chamber

Membership No. :	78487	78487	رقم العضوية الموحد :
Date of Issue:	07/07/2014	2014/07/07	تاريخ الاصدار:
Membership Class :	Second	الثانية	درجة العضوية :
Riyadh Chamber Certifies			تشهد الغرفة التجارية الصناعية بالرياض بأن شركة خليج الخرسانة المحدودة
Commercial Registration No.	1010419075	1010419075	مقيدة بالسجل التجاري / الترخيص رقم :
Certificate Expires on	15/01/2027	2027/01/15	ينتهي سريان هذه الشهادة في

الخدمات الإلكترونية
E-SERVICES

الخدمات الإلكترونية لغرفة الرياض - بوابة أعمال © E-Services Riyadh Chamber

920004565

- يلزم التحقق من الوثيقة عبر الرابط <https://mybusiness.chamber.sa> ، أو تطبيق (سند) للأجهزة المحمولة أو الرقم الموحد دون ادنى مسؤولية على الغرفة عن محتوى الوثيقة.
- تعد هذه الورقة من الوثائق الإلكترونية لغرفة الرياض، ويمنع تعديلها اول محاولة العبث بها وتصبح لاغية حال محاولة تعديلها وتعرض صاحبها للملاحقة القانونية.

Monshaat Certification

منشآت
monsha'at
الهيئة العامة للمنشآت الصغيرة والمتوسطة
Small Medium Enterprises General Authority

رقم الشهادة: 2227555681

اسم المنشأة: شركة خليج الخرسانة المحدودة تاريخ الإصدار: 28-05-2022

صلاحية الشهادة: سنة من تاريخ الإصدار *

الرقم الوطني: 7001856652

السجل التجاري: 1010419075



تشهد الهيئة العامة للمنشآت الصغيرة والمتوسطة "منشآت" بأن المنشأة المذكورة أعلاه تدرج من ضمن المنشآت الصغيرة والمتوسطة وفقاً للتعريف المعتمد لدى "منشآت"

يتم التحقق من الشهادة من خلال موقع منشآت

<https://profile.monshaat.gov.sa/validate>

تعد هذه الشهادة من الوثائق الحكومية الرسمية، ولا يجوز تداولها أو استعمالها إلا في حدود الأغراض التي أصدرت لأجلها، ويحظر قطعياً تقليدها أو إدخال أي تعديلات عليها سواء بالإضافة أو الحذف أو التغيير في بياناتها أو غير ذلك من أنواع التعديل، وتعد هذه الشهادة لاغية إذا شابها شيء من ذلك، كما تعرض من ارتكب أي مما سبق إلى الملاحقة النظامية أمام الجهات المختصة دون الإخلال بما تنص عليه الأنظمة ذات العلاقة.

* يجب التحقق من خلال رابط موقع منشآت عن صلاحية الشهادة حيث أنه يتم التحديث بشكل دوري



الموضوع: طلب تاهيل لاعمال فواصل التمدد بالجسور

المحترمين

السادة شركة خليج الخرسانة المحدودة
(٧٠٦٠ طريق الملك عبدالعزيز - المروج | الرياض ١٢٢٨٢ - ٤٥١٣)

السلام عليكم ورحمة الله وبركاته

إشارة لخطابكم المقيد لدينا برقم ٥٩١٢٧ وتاريخ ١٤٤٢/٨/١٠هـ، وإشارة لخطابكم المقيد لدينا برقم ١٦١٢٤ بتاريخ ١٤٤٢/٠٣/٠١هـ بخصوص طلب اعتماد وتأهيل شركتكم (شركة خليج الخرسانة المحدودة) كمقاول باطن بمشاريع تشغيل وصيانة ونظافة طرق المملكة بوزارة النقل، وبعد الإطلاع على المرفقات ودراسة الأوراق الثبوتية والجهاز الفني وخبرات الشركة وأعمالها السابقة، نفيديكم بأنه لا مانع لدينا من تأهيلكم كمقاول باطن معتمد لدى وزارة النقل لتنفيذ الأعمال الآتية:

1. تنفيذ وتركيب فواصل التمدد للجسور بأنواعها.
2. أعمال إصلاح وحماية الخرسانة وحقن ومعالجة الشروخ الانشائية وغير الانشائية.
3. تنفيذ أعمال العزل المائي والدهانات المضادة للكربنة (Anti-carbonation).
4. أعمال التدعيم باستخدام سرائح الكربون فايبر والقمصان المعدنية.
5. أعمال حقن التربة وتثبيت التربة بالخرسانة المقذوفة والخوازيق الأبرية.
6. أعمال الحماية الكاثودية للعناصر الانشائية.

وذلك اعتباراً من تاريخ خطابنا هذا ولمدة (سنة واحدة) شريطة إلتزامكم بالموصفات العامة للوزارة، علماً أنه في حالة عدم إلتزامكم بالموصفات فإنه سيتم وبدون سابق إنذار إلغاء اعتمادكم.

وتقبلوا أطيبي تحياتي...

المملكة العربية السعودية Saudi Arabia
Tel.+966118744444 / P.O.Box11178



SaudiTransport



مدير عام الإدارة العامة للصيانة
تم اعتماد الخطاب إلكترونياً
المهندس / عمر بن قربان نياز

« ص / مع التحية ل سعادة مدير ادارة صيانة المنشآت والجسور



المملكة العربية السعودية Saudi Arabia
Tel.+966118744444 / P.O.Box11178



SaudiTransport





ACCREDITATION CERTIFICATION



Accreditation Certificate



شركة الأعمال التطويرية المحدودة
Development Works Co. LTD

الرقم: 9320/ش/ع/2205
التاريخ: 1443/10/22 هـ
الموافق: 2022/05/23 م

شهادة إنجاز أعمال

يسر شركة الأعمال التطويرية المحدودة أن تقدم شهادة إنجاز أعمال للمقاول شركة خليج الخرسانة لإنجازها تنفيذ أعمال التدعيم بنظام الألياف الكربونية في مشاريع المدارس التعليمية في المنطقة الشرقية والتابعة لوزارة التعليم، حيث أنجز المقاول الأعمال في الوقت المحدد وطبقاً للمواصفات وبصفة مرضية.

وتفضلوا بقبول وافر الإحترام والتقدير !!!

المدير التنفيذي للمشاريع

م/عصام عاشور



رأس المال ٧٥.٠٠٠.٠٠٠ ريال - سجل تجاري ١٠١٠٩٦٢٢٠ - العضوية: ١٤٤٣١ - ص ب ٣٤١٥٣١ الرياض ١١٣٣٣ - هاتف: ٤٦٠٠٠١٦ (٩٦٦ ١١) - فاكس: ٤٦٠٩٣٥٦ (٩٦٦ ١١)
Capital 75,000,000 SR - C.R. 1010196220 - C.C. 144310 - P.O. Box: 341531 - Riyadh 11333 - Tel. (+966 11) 4600016 - Fax: (+966 11) 4609356

١٤٤١\١٨١٠\٣٩٥٩٤٩
١٤٤١-٠٧-٠٦



السادة شركة ثبات للإنشاءات المحدودة
المحترمين

ص.ب (١٠٠٦٠٠) الرياض (١١٦٤٥) فاكس (٠١١-٢٧٨٣٢٩٠)

صورة للاستشاري تضامن مكتب أبا الخيل وشركة ويتفين ويوس
المحترمين

ص.ب (٤٠٧٤) الرياض (١١٤٩١) فاكس (٤٧٦٤٨٤١)

السلام عليكم ورحمة الله وبركاته

إشارة إلى عقد استكمال مشروع تصميم وتنفيذ محطة معالجة مياه الصرف الصحي بطريق الخرج المرحلة الثالثة بمدينة الرياض مقاولتكم، وإشارة إلى خطابكم رقم (P201190348-SUB-0019) وتاريخ ٢٠٢٠/٠٢/٠٢م (المرفق)، بخصوص طلبكم الموافقة علي اعتماد مقاول الباطن المقترح (شركة خليج الخرسانة المحدودة) لأعمال العزل المائي وأعمال إصلاح الخرسانة بالمشروع أعلاه.

أحيطكم بأنه لا مانع لدينا من اعتماد المقاول الباطن المقترح شركة خليج الخرسانة المحدودة (رقم التأهيل 18158) للقيام بالأعمال المذكورة في المشروع أعلاه وتحت مسؤوليتكم الكاملة من حيث الأداء المرضي والسلامة في الموقع.
مع أطيب تحياتي،،

مدير إدارة تنفيذ مشاريع الخدمات البيئية

م. عبد الله بن ظافر الدوسري

١٤٤١/ ٧/ ٦ هـ

www.nwc.com.sa

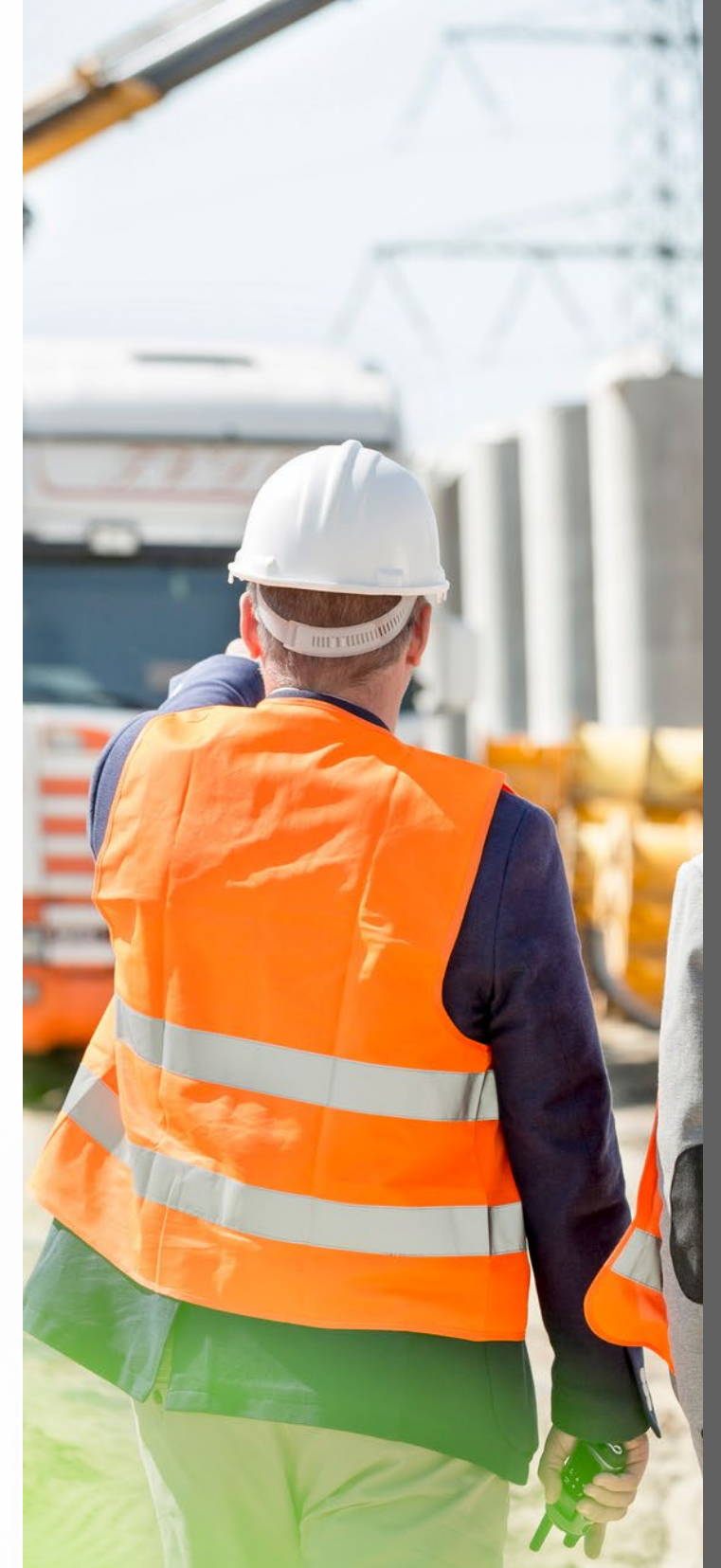

Accreditation Certificate



June 19, 2022

June 19, 2022

To Whom It May Concern

This is to certify that M/S. GULF CRETE LTD. is one of our approved applicators covering the Kingdom of Saudi Arabia.

It may be noted that this certificate does not cover or imply any responsibility or liability for workmanships or failure of the system. This certificate is issued upon request of applicator to Bitumat.

The certificate is non-exclusive and valid for period of one year from the date of issue and to be renewed for further period of one year.

For Bitumat Company Limited,

Mr. Syed Abdullah Rizvi / ت.أ.أ.
Technical Advisor / أ.م.ت.أ.أ.



Head Office : Dammam P.O. Box 7487 Zip Code : 31462 - K.S.A.
Phone : +96613 8121210 / 8121213 Fax: +96613 8121190 Chamber of Comm : 1848
Riyadh : P.O. Box 58698 Zip Code : 11515 Phone : 4770443 / 4792553 Fax: 4762318
Jeddah : P.O. Box 12005 Zip Code : 21483 Phone : 6644449 / 6644868 Fax: 6646598
Paid up Capital : SR 60,000,000 - C.R. : 2050014708 www.bitumat.com

شركة صناعات المواد العازلة للماء ديرمابيت المحدودة DWI, DERMABIT Waterproofing Industries Co. Ltd.



Fully Paid up Capital S. R. 11.5 Million
C. R. : 1010048740
VAT No. 300534295800003
RIYADH BRANCH : P. O. BOX 5945,
RIYADH 11432 - SAUDI ARABIA
TEL.: +966 11 464 5988 FAX : +966 11 463 4100
Email : dermabit@dermabit.com
Website : http://www.dermabit.com

رأس المال المدفوع بالكامل ١١.٥ مليون ريال سعودي
سجل تجاري : ١٠١٠٠٤٨٧٤٠
الرقم الضريبي : ٣٠٠٥٣٤٢٩٥٨٠٠٠٠٣
فرع الرياض : ص.ب ٥٩٤٥
الرياض ١١٤٣٢ - المملكة العربية السعودية
تلفون : +٩٦٦ ١١ ٤٦٣٤١٠٠ فاكس : +٩٦٦ ١١ ٤٦٤٥٩٨٨
dermabit@dermabit.com : البريد الإلكتروني
http://www.dermabit.com : الموقع البريدي

Date : 19/06/2022
Ref.: 1910/22

التاريخ : ٢٠٢٢/٠٦/١٩ م
الرقم : ١٩١٠/٢٢

TO WHOM IT MAY CONCERN

إلى من يهمه الأمر

We, DWI, Dermabit Waterproofing Industries Co., Ltd, 100% Saudi manufacturer of waterproofing systems, do hereby certify that M/S.GULF CRETE CONTRACTING. - Riyadh, have a good and an adequate experience for a long period in installing our waterproofing products in Saudi Arabia. They are one of our approved waterproofing contractors.

تشهد شركة صناعات المواد العازلة للماء ديرمابيت المحدودة شركة سعودية ١٠٠٪ ومنتجة لأنظمة العزل المائي البتومينية بأن شركة خليج الخرسانة ومقرها الرياض هي متخصصة ومعتمدة في مجال تركيب أنظمة العزل المائي التي تنتجها شركة ديرمابيت لفترة طويلة ولديها خبرة جيدة ومناسبة لتنفيذ المشاريع داخل المملكة العربية السعودية.

This certificate does not imply any responsibility on our part for quality control of workmanship or any contractual liabilities.

اعطيت هذه الشهادة بناء على طلبهم دون أدنى مسؤولية على شركة ديرمابيت فيما يتعلق بأي أضرار متزنية على عيوب قد تنشأ عن الخطأ في تركيب المنتجات وخلافه.

Validity of this certificate is for one year from the above mentioned date and is subject to Dermabit's regular and annual evaluation.

صلاحية هذه الشهادة لمدة عام واحد من تاريخه وتخضع للتقييم السنوي المعتاد.

Best regards,

DWI, DERMABIT WATERPROOFING INDUSTRIES CO., LTD

MARWAN KULLAB
Asst. sales Manager

شركة صناعات المواد العازلة للماء ديرمابيت المحدودة
فرع الرياض : رقم الضريبة : ٣٠٠٥٣٤٢٩٥٨
DWI, Dermabit Waterproofing Industries Co. Ltd.
Riyadh Branch - C.C. 32167



المكتب الرئيسي : ص.ب ١٠٣٠٨ مدينة الجبيل الصناعية ٣١٩٦١ المملكة العربية السعودية تلفون : +٩٦٦ ١٣ ٣٤١٠٤٦٤ فاكس : +٩٦٦ ١٣ ٣٤١٠٤٨١ ص.ب : ٣٠٥٠٠١٠٢٤
HEAD OFFICE : P. O. BOX 10308, JUBAIL INDUSTRIAL CITY 31961 SAUDI ARABIA TEL.: +966 13 3410464 FAX: +966 13 3410481 C.R.: 2055001024



Accreditation certificate

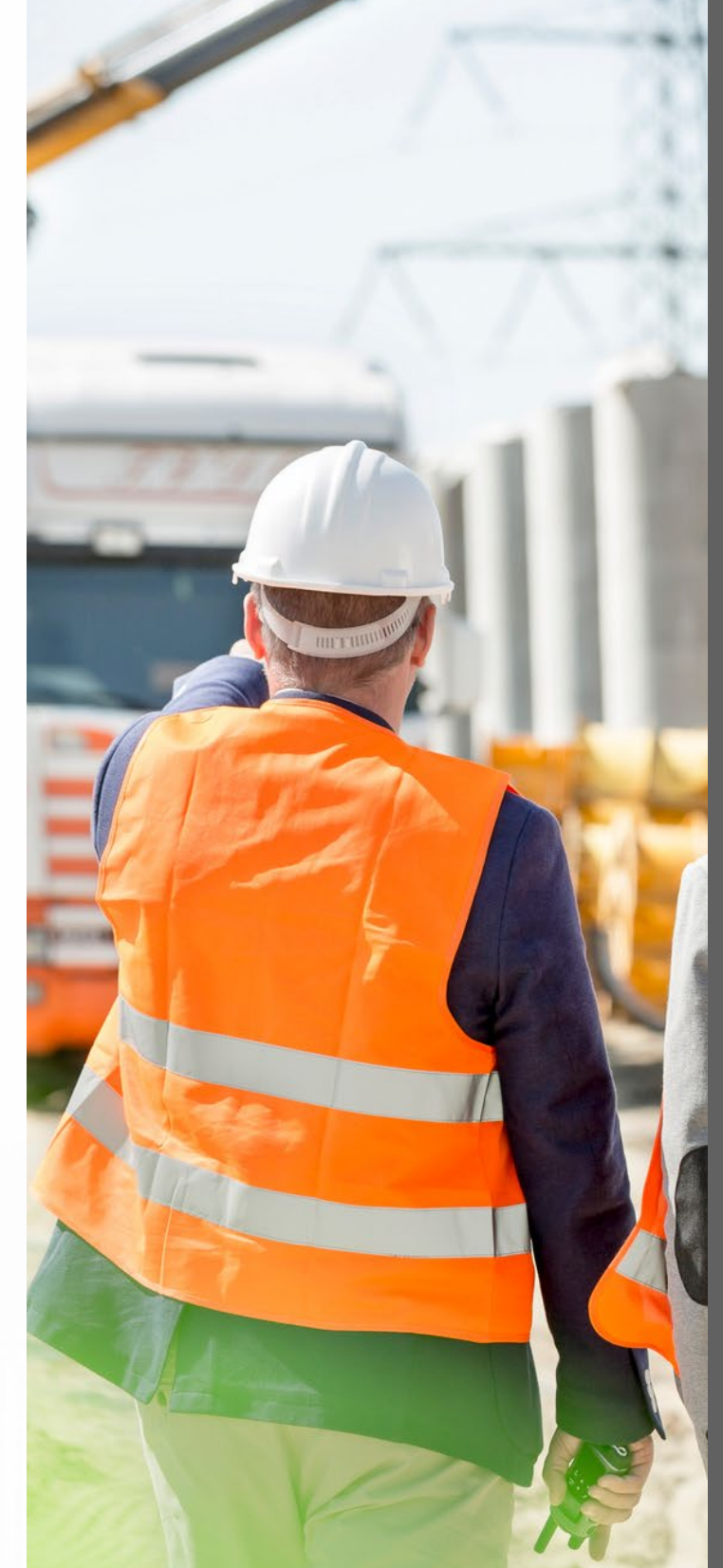

CERTIFICATION

Accreditation Certificate

CERTIFICATION

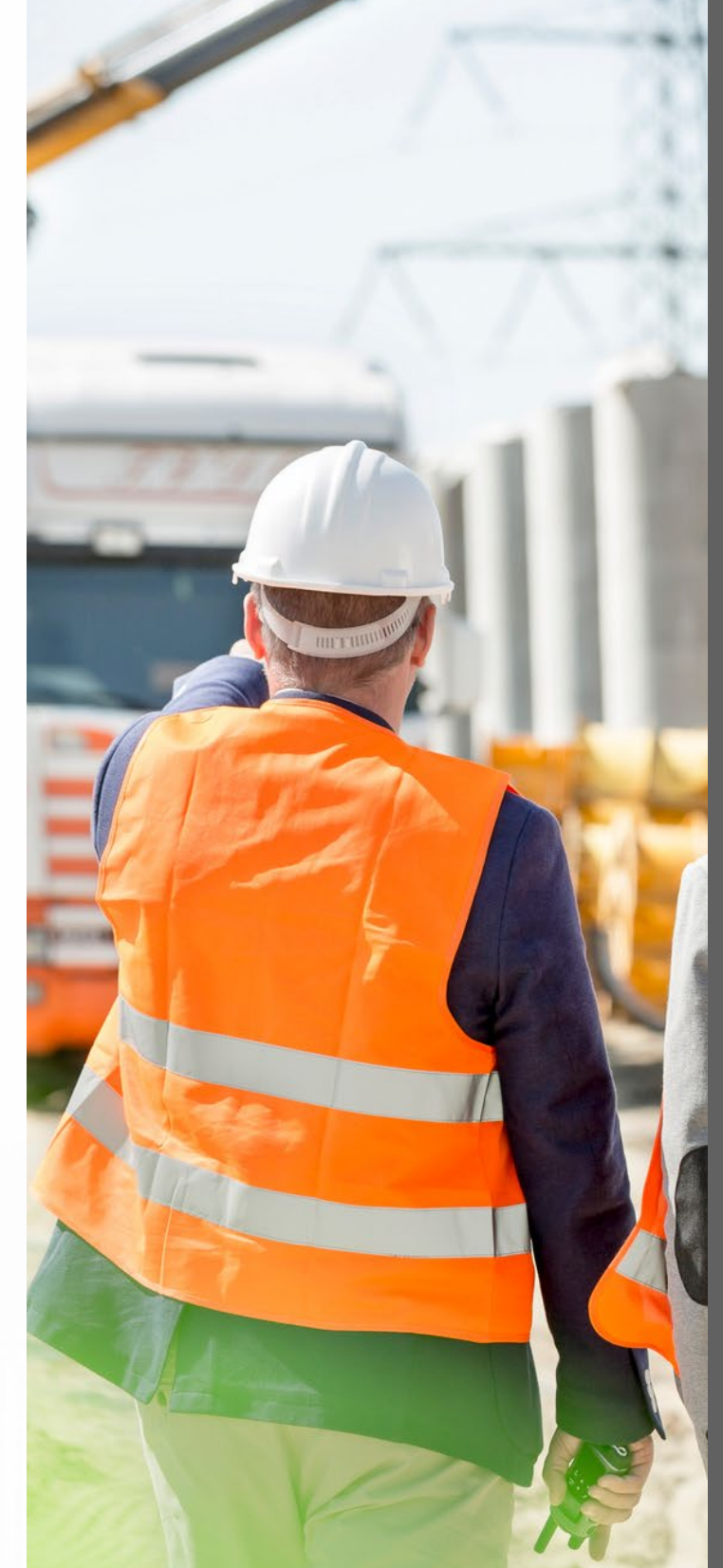

Accreditation Certificate

dun & bradstreet
D-U-N-S Number® Certificate

This is to certify that

GULF CRETE LTD

Building 40 & Office 23,
Al Urubah Street,
Riyadh,
Saudi Arabia

is now part of the
Dun & Bradstreet Global Database

D&B D-U-N-S Number®
55-784-9513

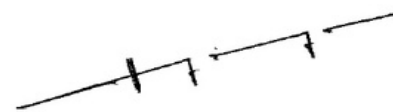

R Suryanarayan
General Manager Africa
Dun & Bradstreet South Asia Middle East Limited

January 9, 2017

 Dun & Bradstreet South Asia Middle East Ltd.

ISOLATEK
INTERNATIONAL

GREEN TECH
THERMAL INSULATION PRODUCTS MFG. LLC
جرين تك لصناعة مواد العزل الحراري
Factory: P.O. Box: 3343, Umm Al Quwain, U.A.E
Tel: +971 6 767 2327
Sales Office: Business Bay, Dubai, U.A.E
Tel: +971 4 352 6210

Date: 01 January 2010

TO WHOM IT MAY CONCERN

Re: Recognized Applicator Certificate

This letter is to confirm that **M/S GULF CRETE LTD**
P.O. BOX 28593
RIYADH - 11323
KINGDOM OF SAUDI ARABIA.

has been identified as a Recognized Applicator for ISOLATEK Fireproofing Systems: ISOLATEK TYPE MII High Density SFRM.

ISOLATEK/GREENTECH operates a global network of Recognized Applicators, all of whom have been instructed in the application techniques of individual products, have been issued with on-site Application Guidelines and received regular updates of such guidelines.

In the event that **M/S GULF CRETE LTD** secures Fireproofing contracts for ISOLATEK Products and Systems, ISOLATEK/GREENTECH will ensure that the installation will be completed in accordance with the recognized practices.

Our standard of re-validation is every 3 years from the date of issue.

Yours Sincerely,

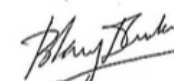

Blány D' Cunha
Managing Director Sales
Greentech Thermal Insulation Products Mfg. LLC



www.isolatek.com | technical@greentech-isolatek.com

Greentech is an Authorized and Licensed Manufacturer & Supplier of Isolatek International Fireproofing

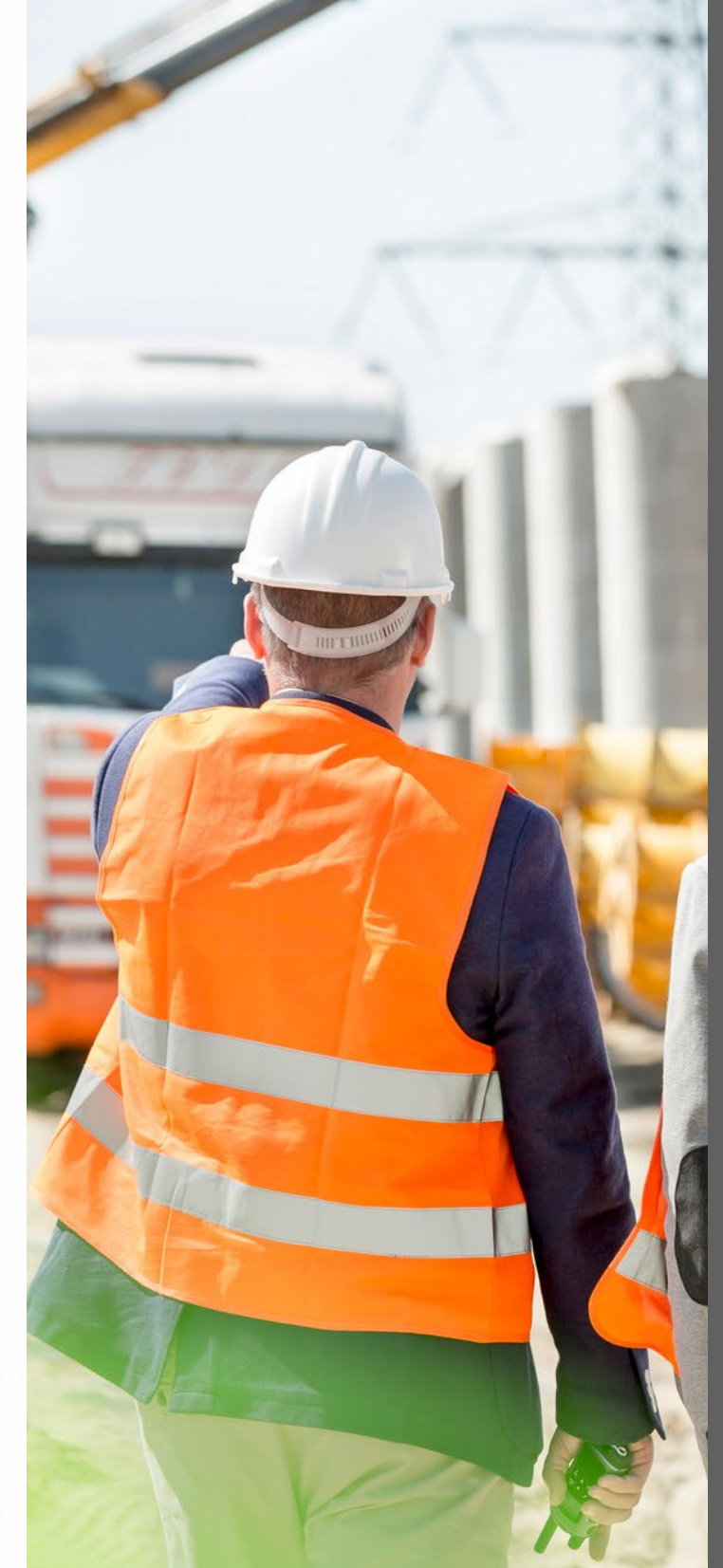

Accreditation Certificate



To Whom it May Concern

Subject: Gulf Crete Vendor IDs Details

Sr#	Vendor ID	Client Name	Status
01	VDR56807	The Red Sea Global	Active
02	1100001590	Neom	Active
03	S10145449	Qiddiya	Active
04	10060363	Aramco	Active
05	5017966	Saudi Electricity Co	Active
06	11045363	Sabic	Sabic Supplier Portal was migrated to SAP ARIBA the new Vendor ID is under process.
07	18158	NWC	Active
08	1002234	SWCC	Active
09	094-01731	Nesma	Active
10	3187	Saudi Railway	Active
11		Gaca	Active
12	2900851	Royal Commission	Active
13	4828	El Seif	Active

Prepared By: Gulf Crete Ltd D.C

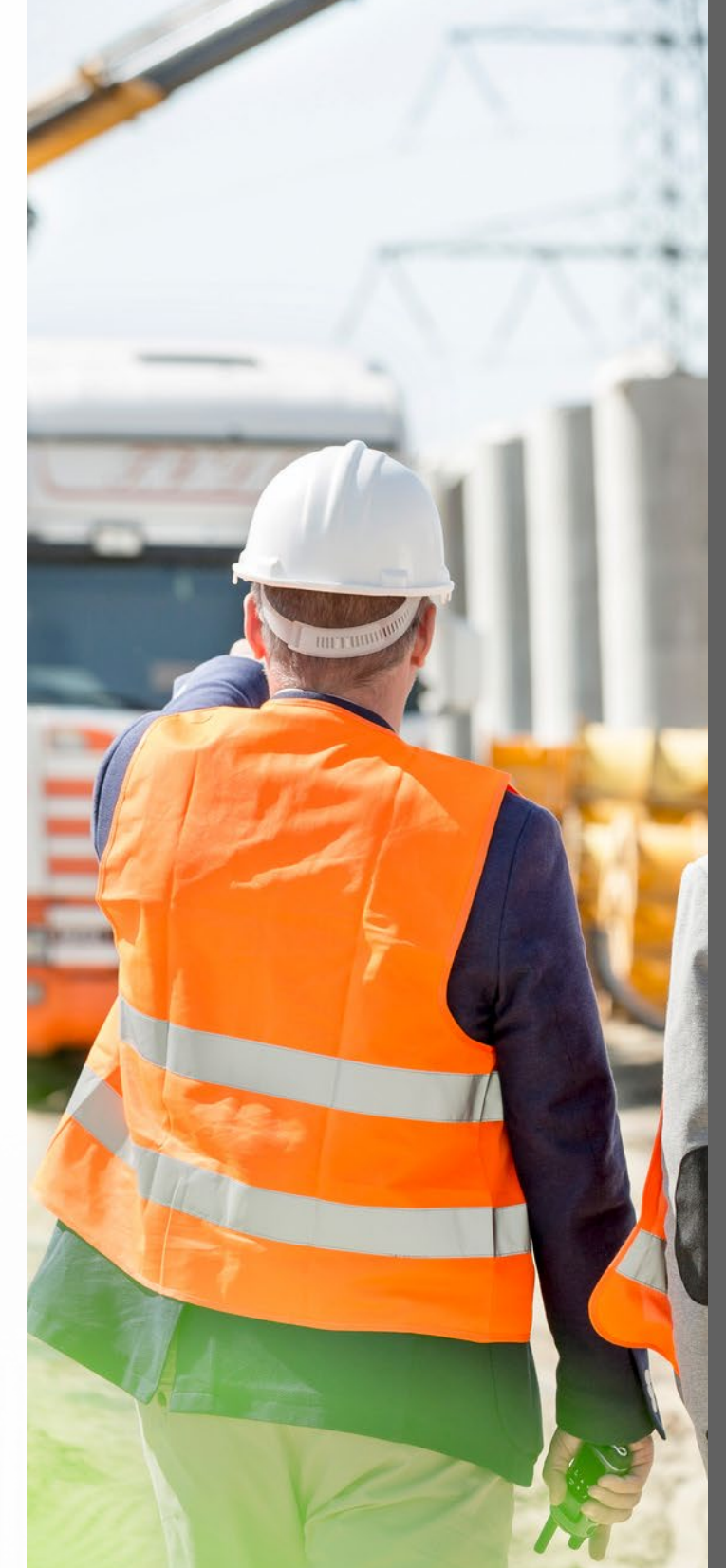



WORK CERTIFICATION





MAIL TYPE: Workflow Transmittal
 MAIL NUMBER: BEC-WTRAN-057428
 REFERENCE NUMBER: BEC-WTRAN-057428

Final (WF-044603) 07-184000-1100001342-MAG-CPM-PQD-000004_WO 031 - NEOM Trojena – Construction of Early Works Permanent Roads – Discover, Explore and Villages Pre-Qualification Documents of Gulf Crete Ltd for Rock Fall/Mesh

From: Mr Hamada Fathalla - Bechtel KSA
 To (3): Bechtel Document Management TROJENA - Bechtel KSA, Mr Hamada Fathalla - Bechtel KSA, 1100001342DCC MASCO - MASCO
 Cc (3): Mr Mohit Jain - Bechtel KSA, Mr Mostafa Darwish - Bechtel KSA, NEOM Trojena Document Control - NEOM - Projects
 Sent: Saturday, December 30, 2023 8:16:39 AM AST (GMT +03:00)
 Status: N/A

DOCUMENT ATTACHMENTS (2)

(0 selected)

File	Document No	Revision	Revision Date	Title	Status
	07-184000-1100001342-MAG-CPM-CRS-000004	01	12/7/23	WO 031 - NEOM Trojena – Construction of Early Works Permanent Roads – Discover, Explore and Villages Pre-Qualification Documents of Gulf Crete Ltd for Rock Fall/Mesh	A - Work May Proceed
	07-184000-1100001342-MAG-CPM-PQD-000004	01	12/7/23	WO 031 - NEOM Trojena – Construction of Early Works Permanent Roads – Discover, Explore and Villages Pre-Qualification Documents of Gulf Crete Ltd for Rock Fall/Mesh	A - Work May Proceed

MESSAGE

Workflow Review History

The attached documents have completed the "07-184000-1100001342-MAG-CPM-PQD-000004_WO 031 - NEOM Trojena – Construction of Early Works Permanent Roads – Discover, Explore and Villages Pre-Qualification Documents of Gulf Crete Ltd for Rock Fall/Mesh" workflow with the following results :

This transmittal was automatically generated.

Doc No	Step	Participant	Review Outcome	Comments
07-184000-1100001342-MAG-CPM-PQD-000004	PMC DCC	H Fathalla	A - Work May Proceed	
07-184000-1100001342-MAG-CPM-CRS-000004	PMC DCC	H Fathalla	A - Work May Proceed	





Document Title: DOCUMENT SUBMISSION FORM (DSF)		Project Name: INFRASTRUCTURE, AND NETWORKS-84 RBF IN DAMMAM-2		Project Contractor: Gulf Builder	
Project Number: DAM2-01-010		Project Consultant: Worley		Document Reference No: DAM2-02-010-GB-TS9-3-DSF-CVL-000014-00	
CIVIL & STRUCTURAL					
DOCUMENT ISSUED BY			DOCUMENT RECEIVED BY		
Issued By	Engr Ahmed Abdel Fatah		Received By	SULIMAN NOJYFAN	
Position/Company	Project Manager		Position/Company	D.C.	
Signature	<i>[Signature]</i>		Signature	<i>[Signature]</i>	
Date	11-02-2020		Date	17/02/2020	
ATTACHMENTS					
source		Manufacturer		Bill of Quantities	
Certification		Manual		Method Statement	
✓ Sub-contractor		✓ Pre-qualification		Technical Information	
Engineering Calculation		Procedure/ Methodology		Bank Warranty	
Job Order		Product Data		Letter	
Sample		Test Report		Shop drawings	
PURPOSE FOR DOCUMENT SUBMISSION					
FOR INFORMATION	<input type="checkbox"/>	FOR REVIEW & APPROVAL	<input type="checkbox"/>	AS REQUESTED	<input type="checkbox"/>
SUBMITTED DOCUMENTS REFERENCE NUMBERS					
#	Document Reference No.	Document Description	Rev.	Hard Copy	Soft Copy
1	GULF CRETE LTD.	Contractor for Water proofing and Insulation Work	00		✓
2					
RESPONSE STATUS					
APPROVED AS SUBMITTED (APP)	<input checked="" type="checkbox"/>	APPROVED AS NOTED (APN)	<input type="checkbox"/>	REJECTED/RE-SUBMIT (RRS)	<input type="checkbox"/>
COMMENTS					
* The Subcontractor is approved for the water proofing and insulation works only. 13/2/20					
RESPONSE ISSUED BY			RESPONSE RECEIVED BY		
Issued By	Basam Saad		Received By	<i>[Signature]</i>	
Position/Company	CM		Position/Company	D.C.	
Signature	<i>[Signature]</i>		Signature	<i>[Signature]</i>	
Date	13/02/20		Date		
<small>Note: Approval by the consultant shall not release the contractor of its obligations and liabilities under the contract in case of any discrepancy between the inspected works and final approved designs, the contractor shall carry out the necessary remedies, rectifications, demolition and reconstruction according to the final approved design without the right to claim extra cost and time</small>					

ألومنيوم
Aluminium

الغريير للإنشاءات
Al Ghurair Construction

شهادة انجاز

بهذا تشهد شركة الغريير للإنشاءات والالومنيوم بأن شركة خليج الخرسانة , قد قامت بتنفيذ مشروع عزل اسقف محطات الباصات الخاصة بمشروع الملك عبدالعزيز للنقل العام لجميع المحطات والجسور بالمشروع المرحلة الثالثة في مدينة الرياض , (TPO waterproofing membrane System with Rockwool, Glass Board And corrugated metal Sheet)

كما تشهد شركة الغريير للإنشاءات بان شركة خليج الخرسانة قد أوفت بكافة التزاماتها الخاصة بهذا المشروع بكفاءة ووفقا للجدول الزمني المحدد لها وبصفة مرضيه .

وقد اعطيت هذه الشهادة لشركة خليج الخرسانة كشهادة انجاز لاعمال المشروع بنجاح.

التوقيع
فهد شيخة AP

شركة الغريير للإنشاءات والالومنيوم العربية
Al Ghurair Construction & Arabian Aluminium LLC

شركة الغريير للإنشاءات والالومنيوم العربية د.م.
P.O. Box 259223, P. Code 11351
Al Riyadh, Saudi Arabia
T +966 1 4629200
F +966 1 4640092
www.al-ghurair.com





23, 9:07 AM

Aconex

Bechtel Document Management Final (WF-085561) WO 045 - Spine Earthworks Lot 10-2 ... 8:53 AM
 BECHTEL KSA WORKFLOW TRANSMITTAL BEC-WTRAN-177461

10 Spine Infrastructure
 Spine Infrastructure
 NEOM
 Saudi Arabia



MAIL TYPE MAIL NUMBER REFERENCE NUMBER
 Workflow Transmittal BEC-WTRAN-177461 BEC-WTRAN-177461

Final (WF-085561) WO 045 - Spine Earthworks Lot 10-2 Ch 73+500 To Ch 75+500 (Coastal Desert Region) - Pre-Qualification Document for GULF CRETE LTD. CONTRACTING COMPANY for Application of Shotcrete

From Bechtel Document Management - Bechtel KSA
 To (2) Bechtel Document Management - Bechtel KSA (+1 more...)
 Cc (2) NEOM Quality & Excellence Document Control - NEOM - Engineering & Technical Services Dept (+1 more...)
 Sent Wednesday, 8 February 2023 8:53:15 AM AST (GMT +03:00)
 Status N/A

DOCUMENT ATTACHMENTS (2)

File	Document No	Revision	Revision Date	Title	Status
	10-603172-0000100201-MAH-CIV-CRS-000068	03	30/01/2023	WO 045 - Spine Earthworks Lot 10-2 Ch 73+500 To Ch 75+500 (Coastal Desert Region) - Pre-Qualification Document for GULF CRETE LTD. CONTRACTING COMPANY for Application of Shotcrete_CRS	A - Work May Proceed
	10-603172-0000100201-MAH-CIV-PQD-000018	03	30/01/2023	WO 045 - Spine Earthworks Lot 10-2 Ch 73+500 To Ch 75+500 (Coastal Desert Region) - Pre-Qualification Document for GULF CRETE LTD. CONTRACTING COMPANY for Application of Shotcrete	A - Work May Proceed

MESSAGE

Workflow Review History

The attached documents have completed the "WO 045 - Spine Earthworks Lot 10-2 Ch 73+500 To Ch 75+500 (Coastal Desert Region) - Pre-Qualification Document for GULF CRETE LTD. CONTRACTING COMPANY for Application of Shotcrete" workflow with the following results :

s/ksa1.aconex.com/hub/index.html?mainTarget=%2FViewCorrespondence%3FCorrespondence_ID%3D1358337652%26CORRESPONDENCE_... 1/2

12/20/21, 9:52 AM

https://ksa1.aconex.com/rsrc/20211215.0853/en_AU_DOC/mail/view/index.html#/1342178863/1351631040?attachedMailParentl...

10 Spine Infrastructure
 Spine Infrastructure
 NEOM
 Saudi Arabia



MAIL TYPE MAIL NUMBER REFERENCE NUMBER
 RFI Circulation Response ACM-RRFI-000016 CRC-RFI-000018

Re: TQ-22A-Technical Clarification on replied TQ-022 Rockfall Fence

From Mr Stoney Mather - AECOM
 To (3) Mr Stephen Purdue - AECOM (+2 more...)
 Cc Alexander Donald Mackay - Bechtel KSA
 Sent Monday, 20 December 2021

MESSAGE

Gentlemen,

In regard to rock fencing, specification 10-136000-0000100595-ACM-TNL-SPC-000009 SECTION 313326 -- ROCK SLOPE WIRE MESH, PART 1 GENERAL, Section 1.1 B.2 and B.4 state:

2. Complete the Detailed Design, manufacture, supply, install and warrant the work, complying with the specified design and performance requirements."

4. Where a particular material, product or supplier is specified, the material, product or supplier shall be deemed indicative representing the Employer's Representative's Design Intent only. Complete the installation using the specified or other product acceptable to the Employer's Representative. Be fully responsible for the Detailed Design and performance of the work.

Also, Section 2.2 indicates: "Rockfall wire mesh shall be flexible nominal TECCO G65/3 high tensile mesh or similar. Components shall have Geobrugg "Ultracoat" corrosion protection or similar corrosion protection and shall not be coated PVC." And IFC plan sheet 10-136000-0000100595-ACM-TNL-DRG-500061 includes an indicative arrangement for rockfall fencing and states: "ROCKFALL FENCE GEOBRUGG GBE-3000A 6m HIGH 3000 kJ CAPACITY OR SIMILAR APPROVED. ROCKFALL FENCE DETAILS AND INSTALLATION TO BE IN ACCORDANCE WITH MANUFACTURER'S REQUIREMENTS" and "LOCATION, ARRANGEMENT, SIZE AND CAPACITY MAY VARY IN RESPONSE TO ROCK SLOPE MAPPING."

Accordingly, the contractor may use G80/4 wire mesh in compliance with the manufacturer's recommendation to achieve the performance requirements (3000kJ) for the rockfall protection system that the contractor has designed, will install, and will warrant.

Thanks.

From: R Kyte
 Sent: 12/20/21 8:36:50 AM AST (GMT +03:00)
 To: Jeremy Cox, Stoney Mather, Stephen Purdue
 Mail Number: BEC-RFIC-000693
 Subject: Fwd: TQ-22A-Technical Clarification on replied TQ-022 Rockfall Fence

Stephen

https://ksa1.aconex.com/rsrc/20211215.0853/en_AU_DOC/mail/view/index.html#/1342178863/1351631040?attachedMailParentId=1351631860





11/7/21, 9:51 AM

Aconex

Bechtel Document Management
BECHTEL KSA

Final (WF-014107) 10-136000-4800000241-CRC-CIV-M... 31/10/2021
WORKFLOW TRANSMITTAL BEC-WTRAN-022701

10 Spine Infrastructure
Spine Infrastructure
NEOM
Saudi Arabia



MAIL TYPE
Workflow Transmittal

MAIL NUMBER
BEC-WTRAN-022701

REFERENCE NUMBER
BEC-WTRAN-022701

Final (WF-014107) 10-136000-4800000241-CRC-CIV-MAT-000019_Material
Submittal for Rockfall Protection Barrier by Gebrugg

From Bechtel Document Management - Bechtel KSA
To (2) Bechtel Document Management - Bechtel KSA (+1 more...)
Cc (6) Colin Watson - Bechtel KSA (+5 more...)
Sent Sunday, 31 October 2021 2:11:11 PM AST (GMT +03:00)
Status N/A

DOCUMENT ATTACHMENTS (2)

File	Document No	Revision	Revision Date	Title	Status
	10-136000-4800000241-CRC-CIV-CRS-000049	01	23/10/2021	Material Submittal for Rockfall Protection Barrier by Gebrugg_CRS	B - Incorporate Comments - Proceed
	10-136000-4800000241-CRC-CIV-MAT-000019	01	23/10/2021	Material Submittal for Rockfall Protection Barrier by Gebrugg	B - Incorporate Comments - Proceed

MESSAGE

Workflow Review History

The attached documents have completed the "10-136000-4800000241-CRC-CIV-MAT-000019_Material Submittal for Rockfall Protection Barrier by Gebrugg" workflow with the following results :

This transmittal was automatically generated.

Doc No	Step	Participant	Review Outcome	Comments
14-662000-4800000322-	NEOM/AECOM_Review	K Mekhimer	B - Incorporate Comments	Refer to CRS & PDF

<https://ksa1.aconex.com/Logon>

1/2

Khali Mekhimer
AECOM

Final (WF-028196) 14-4800000322/000-IN-Project Mana... 28/07/2022
WORKFLOW TRANSMITTAL ACM-WTRAN-055262

14 Outer Regions
Riyadh, KSA
Riyadh
Saudi Arabia



MAIL TYPE
Workflow Transmittal

MAIL NUMBER
ACM-WTRAN-055262

REFERENCE NUMBER
ACM-WTRAN-055262

Final (WF-028196) 14-4800000322/000-IN-Project Management - IFR (PQD)

From Mr Khalil Mekhimer - AECOM
To (2) Mr Khalil Mekhimer - AECOM (+1 more...)
Cc (9) Khaled Ismail - AECOM (+8 more...)
Sent Thursday, 28 July 2022 11:20:53 AM AST (GMT +03:00)
Status N/A

DOCUMENT ATTACHMENTS (2)

File	Document No	Revision	Revision Date	Title	Status
	14-662000-4800000322-MOB-CIV-CRS-000225	01	07/07/2022	4800000322/000 - Prequalification Of GCL For Fire Paint	B - Incorporate Comments - Proceed
	14-662000-4800000322-MOB-CIV-PQD-000053	01	07/07/2022	4800000322/000 - Prequalification Of GCL For Fire Paint	B - Incorporate Comments - Proceed

MESSAGE

Workflow Review History

The attached documents have completed the "14-4800000322/000-IN-Project Management - IFR (PQD)" workflow with the following results :

This transmittal was automatically generated.

Doc No	Step	Participant	Review Outcome	Comments
14-662000-4800000322-	NEOM/AECOM_Review	K Mekhimer	B - Incorporate Comments	Refer to CRS & PDF





Doc No: DG-DSQ-316-0000-SSA-PQQ-PR-000188
 Revision: 00
 Date: 18 August 2022
 Page: 1 of 2



(DRF) Document Review Form (Submittal)

Part 1 – Issue / Receive / Distribute

Employer: Diriyah Gate Development Authority
 Contractor: Salini Saudi Arabia
 Project: DSQ Package 2 – Super Basement
 Contract/ Work Package: DD-2020-249 / DSQ 316
 Construction Supervisor: AECOM Arabia

Document Type	Document Reference
PREQUALIFICATION	DG-DSQ-316-0000-SSA-PQQ-PR-000188(00)

Document Description	
Title	PREQUALIFICATION- Subcontractor for Epoxy Coating Applicator (Subcon: Gulf Crete Ltd)
Package:	DSQ Package 2
Discipline:	Procurement
Work Location:	Package 2 super basement

List of Attachments (If Any)	

Issued By: Contractor

Name:	Marco Tentorio	Date:	18 August 2022
Role:	Contractor's Representative		
Signature & Stamp:			



Document Submittal

Project Name:	RUA AL MADINAH PROJECT MAIN INFRASTRUCTURE PACKAGE		
Contractor:	Al Ajmi & CR18G	Contractor Ref #:	MIP-JVC-PQD-CIV-000093-00
PMC:	Parsons	TSC:	WSP
Location:	Al-Madinah	Date:	21-Mar-23

Please check appropriate box:

<input type="checkbox"/> Letter	<input type="checkbox"/> Technical Report	<input type="checkbox"/> Shop Drawing
<input type="checkbox"/> Technical Submittal	<input type="checkbox"/> GIS or CAD	<input type="checkbox"/> Reports
<input type="checkbox"/> Bill of Quantities	<input type="checkbox"/> Material Approval	<input type="checkbox"/> Test Reports
<input type="checkbox"/> Procedure or Methodology	<input type="checkbox"/> Engineering Calculation	<input type="checkbox"/> Permissions
<input type="checkbox"/> PM Plan	<input type="checkbox"/> Program	<input type="checkbox"/> Manuals
<input type="checkbox"/> Product Data	<input type="checkbox"/> As Built	<input type="checkbox"/> Others (please specify)
<input checked="" type="checkbox"/> Pre-qualification	<input type="checkbox"/> Certificates	
<input type="checkbox"/> Material Sample	<input type="checkbox"/> Drawings	

Purpose: For Information For Review & Approval As Requested

Subject: Prequalification for Company Gulf Crete Ltd as a Sub Contractor for water proofing work.

Document Description:

SR. No.	Document No.	BoQ #	Document Name	Rev.	Hard Copy	Soft Copy
1	MIP-JVC-PQD-CIV-000093-00		Prequalification for Company Gulf Crete Ltd as a Sub Contractor for water proofing work.	00		✓
2						
3						

Contractor PM: Name: Ahmed Roshdy Date: 21-Mar-23 Signature: Stamp

WSP Review & Approval Status <input type="checkbox"/> A - Approved (Work may proceed) <input checked="" type="checkbox"/> B - Approved as Noted (Work may proceed subject to Incorporation of Comments) <input type="checkbox"/> C - Revise and Resubmit (Work may not proceed) <input type="checkbox"/> D - Rejected <input type="checkbox"/> E - For Information	Discipline Engineer / QA-QC Manager Name: Mohamed Samy Eleissawy Sign: Date: 27 Mar
---	--

Comments:
 1-Gulf Crete Ltd as a Sub Contractor for waterproofing work has to provide/update the missing Docs, according to the attached checklist prior to starting any activity.
 2-Waterproofing installation MOS with warranty certificate draft has to be submitted by Gulf Crete Ltd as a Sub Contractor for review and approval.
 3-The Gulf Crete Ltd has to provide an approval certificate for application of the system from the waterproofing manufacturer.
 4-The organization chart of the assigned qualified staff on the project has to be submitted for review and approval

WSP Resident Engineer
 Name: Mohamed Salama Sign: Date: 27/03/2023
 Mahmoud Abbas







MATERIAL APPROVAL REQUEST			
Project:	Construction of the water transmission line and water Reservoir – Riyadh, Sedra2	Ref No.:	00102-AST-REQ-MR-00276
Client:	ROSHN	Rev. No.:	1
Engineer:	SAPL	Submital:	CMI Date: 9/7/2023
Contractor:	ASTRA Construction	Purpose/Use:	
MATERIAL DESCRIPTION			
Description	Material submittal for light weight concrete to roof (foam concrete)	Brand Name:	MAS Foam cement
Material Status:	<input checked="" type="checkbox"/> Specified <input type="checkbox"/> Alternative	Contract Ref:	
Reason for the Change if any			
Discipline/Trade	Civil	Specification:	
Project Name.:	Building:	BOQ Ref. No.:	
Attachments:	<input checked="" type="checkbox"/> Production Verification <input type="checkbox"/> Third Party Test Report	<input type="checkbox"/> Sample Catalogue	<input checked="" type="checkbox"/> Comparison Sheet <input type="checkbox"/> Previous Approval <input type="checkbox"/> List of Suppliers <input checked="" type="checkbox"/> Others (Data Sheet _____)
MANUFACTURER DETAILS		SUPPLIER DETAILS	
Company Name:	MAS paints	Company Name:	Gulf Crete
Address:	KSA	Address:	KSA
DELIVERY DETAILS			
Country of Origin:		Availability:	<input type="checkbox"/> Locally Available <input type="checkbox"/> Imported
Date Material Required on Site:		Estimated Date of Arrival on Site:	
<small>We certify that the above submitted items are correct and in strict conformity with the contract drawings and specifications except otherwise stated; also the material sources indicated above have been checked to ensure the submitted items in full conformity with timely delivery.</small>			
For the Contractor:	Name: Sufian Obaid	Signature:	Date: 9-7-2023 Contractor Stamp
ENGINEER'S REVIEW			
Remarks: 1.This approval based on manufacturer recommendation and warranty certificate. Contractor is responsible to submit the warranty certificate after completion of work with company stamp and signature. 2. Contractor shall arrange mock up and kick of meeting before start activity.			
Is Employer's Approval required <input type="checkbox"/> Yes <input type="checkbox"/> No			
Name:	GHULAM DASTAGEER	Signature:	Date: 10-JULY-2023 Consultant Stamp
Status Code: <input type="checkbox"/> Approved (A) <input checked="" type="checkbox"/> Approved with Comments (B) <input type="checkbox"/> Revise & Resubmit (C) <input type="checkbox"/> Rejected (D)			
PM (CORE TEAM) REVIEW			
Remarks: Contractor shall follow Engineer's comments that comply with contract conditions			
Name:	Abdulrah khraisat	Signature:	Date: 10-July-23
Cost & Time Impact (For Alternative Material)			
Cost	<input type="checkbox"/> Increase <input type="checkbox"/> Decrease	Amount (SAR):	
Time	<input type="checkbox"/> Increase <input type="checkbox"/> Decrease	Days:	
CLIENT'S APPROVAL (Optional)			
Remarks:			
Name:		Signature:	Date:
<small>Approval shall not relieve the Contractor of its obligations and liabilities under the Contract or constitute authorization of any change to Contract Documents, and therefore, shall not imply on recognition whatsoever of additional time or cost to the Contract</small>			

12/8/22, 4:35 PM Aconex

Muhammad Jamali Final (WF-004947) (Astra) Transmission Line-Submittal fo... 3:58 PM
 SAUDI ARABIAN PARSONS LIMITED WORKFLOW TRANSMITTAL SAPL-WTRAN-007430

MAIL TYPE Workflow Transmittal **MAIL NUMBER** SAPL-WTRAN-007430 **REFERENCE NUMBER** SAPL-WTRAN-007430

Final (WF-004947) (Astra) Transmission Line-Submittal for Approval (ARC) 00102-AST-REQ-MR-00128 R1- Material Submittal for Water Proofing System

From Mr Muhammad Jamali - SAUDI ARABIAN PARSONS LIMITED

To (3) Mr Yousuff Shaik - SAUDI ARABIAN PARSONS LIMITED (+2 more...)

Cc (13) Saleh Almarshad - ROSHN Real Estate (+12 more...)

Sent Thursday, 8 December 2022 3:58:29 PM AST (GMT +03:00)

Status N/A

DOCUMENT ATTACHMENTS (1)

File	Document No	Revision	Revision Date	Title	Status
	00102-AST-REQ-MR-00128	01	30/11/2022	Material Submittal for Water Proofing System	B - Approved with Comments

MESSAGE

Workflow Review History

The attached documents have completed the "(Astra) Transmission Line-Submittal for Approval (ARC) 00102-AST-REQ-MR-00128 R1- Material Submittal for Water Proofing System" workflow with the following results :

This transmittal was automatically generated.

Doc No	Step	Participant	Review Outcome	Comments
00102-AST-REQ-MR-00128	Saudi Parsons	M Jamali	B - Approved with Comments	Please check on the attachment

https://ksa1.aconex.com/hub/index.html?mainTarget=%2FViewCorrespondence%3FCorrespondence_ID%3D1356984828%26CORRESPONDENCE_... 1/1





11/5/22, 9:45 AM

Aconex

AbdulAleem Mohammed
SAUDI ARABIAN PARSONS LIMITED

Final (WF-003266) (Astra) Transmission Line-Submittal fo...
WORKFLOW TRANSMITTAL
SAPL-WTRAN-004780

9:27 AM
SAPL-WTRAN-004780



ROSHN



شركة پارسونز العربية السعودية المحدودة

MAIL TYPE: Workflow Transmittal
MAIL NUMBER: SAPL-WTRAN-004780
REFERENCE NUMBER: SAPL-WTRAN-004780

Final (WF-003266) (Astra) Transmission Line-Submittal for Approval (ARC)00102-AST-REQ-MR-00116 -Prequalification documents for Water Proofing System (Tanking , Wet Area , Roofing)

From: Mr AbdulAleem Mohammed - SAUDI ARABIAN PARSONS LIMITED
To (3): Mr AbdulAleem Mohammed - SAUDI ARABIAN PARSONS LIMITED (+2 more...)
Cc (13): Saleh Almarshad - ROSHN Real Estate (+12 more...)
Sent: Saturday, 5 November 2022 9:27:53 AM AST (GMT +03:00)
Status: N/A

DOCUMENT ATTACHMENTS (1)

File	Document No	Revision	Revision Date	Title	Status
	00102-AST-REQ-MR-00116	00	29/10/2022	Prequalification documents for Water Proofing System (Tanking , Wet Area , Roofing)	B - Approved with Comments

MESSAGE

Workflow Review History

The attached documents have completed the "(Astra) Transmission Line-Submittal for Approval (ARC)00102-AST-REQ-MR-00116 - Prequalification documents for Water Proofing System (Tanking , Wet Area , Roofing)" workflow with the following results :

This transmittal was automatically generated.

Doc No	Step	Participant	Review Outcome	Comments
00102-AST-REQ-MR-00116	Saudi Parsons	A Mohammed	B - Approved with Comments	1. The Prequalification for gulf crete is accepted as per attached documents to

<https://ksa1.aconex.com/Logon?Action=View&ENTITY=MAIL&ID=1356263876&USERID=1342279151>

1/2



MAIL TYPE: Workflow Transmittal
MAIL NUMBER: ATK-WTRAN-007510
REFERENCE NUMBER: ATK-WTRAN-007510

Final (WF-161451) Pre-Qualification Documents of GULF CRETE for Thermal and Moisture Protection (Water Proofing)

From: Ms Wejdan Almadi - WS ATKINS & Partners Overseas
To (6): Mr DC Misk Art Institute - SaudCo (+5 more...)
Cc (10): Christian Salas - Misk City Company (+9 more...)
Sent: Monday, 10 July 2023 5:18:43 PM AST (GMT +03:00)
Status: N/A

DOCUMENT ATTACHMENTS (1)

File	Document No	Revision	Revision Date	Title	Status
	P-0006-PHD1-P02-02A15-6CL-PQD-CIV-000008	00	02/07/2023	Pre Qualification Documents of GULF CRETE for Thermal and Moisture Protection (Water Proofing)	C - Revise and Resubmit

ATTRIBUTES

Attribute 1: Civil

MESSAGE

Workflow Review History

The attached documents have completed the "Pre-Qualification Documents of GULF CRETE for Thermal and Moisture Protection (Water Proofing)" workflow with the following results :

This transmittal was automatically generated.

Doc No	Step	Participant	Review Outcome	Comments
P-0006-PHD1-P02-02A15-6CL-PQD-CIV-000008	QA Check	M DC	QA Accepted	
	Step 1 - Review	G Kulkarni	B - Approved with Comments	PQD checklist shall be attached. Riyadh Chamber certificate Expired. ISO Certificate expired. HSE policy shall be signed by Authorised Signatory. Valid Applicator certificate shall be attached for the proposed material for the project. All the documents shall be renewed as required.
	QA/QC	N Panwar	B - Approved with Comments	





Client: DGCL Diriyah Gate Company Limited				شركة المصنعة للبتون SHAD CONSTRUCTORS			
PMC		CSC		CSC Contractor			
COMMENTS RESOLUTION SHEET (CRS)							
REVIEWED DOCUMENT DATA			Final Response Code				
CRS Revision:	0			B-Approved with Comments - Work May Proceed (Subject to Compliance with the Comments) - Resubmission Required			
Workflow Number:	WF-261157						
Subject / Document Title	Pre Qualification Documents of GULF CRETE for Thermal & Moisture Protection and Epoxy Coating	Document Type	PQ				
Document Number:	DG-PIN-471-0000-SCL-PQQ-PR-000073	Document Rev:	0				
Received Date:	17.04.2023	Response Date:	19.04.2023				
Approval Code Legends							
1	A	Approved or Approved as Noted - Work May Proceed - Resubmission Not Required	CSC Representative (Name & Sign):- Miyan				
2	B	Approved with Comments - Work May Proceed (Subject to Compliance with the Comments) - Resubmission Required	CSC Representative (Name & Sign):- Emel Mikhe				
3	C	Revise & Resubmit - Work May Not Proceed	(Optional) PMC / Parsons (Name & Sign):-				
4	D	Rejected / Review Not Required					
No.	Doc # / Section / Page #	Comments	Reviewed and Commented by	Organization	Status	Contractor's Response	Response By
1 st Cycle Comment							
1	PQ	Arrangement of paper i.e. orientation are not proper. Kindly check prior submission.	Miyan	AECOM	Code B	noted and updated	Feras Elbadawy
2	PQ	Safeguarding of Wages certificate to be attached	Miyan	AECOM	Code B	noted and attached - Page 177	Feras Elbadawy
3	PQ	Draft Warranty certificate to be attached.	Miyan	AECOM	Code B	noted and attached - Pages 232-234	Feras Elbadawy
4	PQ	Zakat Certificate already expired.	Miyan	AECOM	Code B	noted and updated - Page 116	Feras Elbadawy
5	PQ	SOI certificate already expired.	Miyan	AECOM	Code B	noted and updated - Page 116	Feras Elbadawy
6	PQ	Sauzdization Certificate already expired.	Miyan	AECOM	Code B	noted and updated - Page 115	Feras Elbadawy
7	PQ	Approval subjected to satisfactory performance and Mock-up at site in compliance with the project specification.	Miyan	AECOM	Code B	noted	Feras Elbadawy
8				Please Select	Please Select		
9				Please Select	Please Select		
10				Please Select	Please Select		
Notes							
1							
2							
3							

Client: 	Consultant: 	Contractor:
TECHNICAL DOCUMENTS		
Project Name: HAIF – Six Flags	Project Code: QC02001	
Location:	Date: 17-October-2022	
Document Title: Prequalification Document for the Gulf-Crete Company	Ref No: QC02001-HAI-TEC-PQD-CIV-00-Z00-00001	
	Rev No: 00	
Department: <input type="checkbox"/> Architectural <input type="checkbox"/> Structural <input type="checkbox"/> Electrical <input type="checkbox"/> Mechanical <input type="checkbox"/> Authority <input checked="" type="checkbox"/> Others		
Type: <input type="checkbox"/> Pre-Qualification <input type="checkbox"/> Method Statement <input type="checkbox"/> Material Submittal <input type="checkbox"/> Sample <input checked="" type="checkbox"/> Other		
Document Description:		
Doc. Ref. No.	Title	
	Prequalification Document for the Gulf-Crete Company	
Enclosure:		
Submitted By: Name: Mohmd. Falah Signature: Date: 17-Oct-2022	Received By: Name: Signature: Date:	
Below portion for Consultant Supervision use only		
Status: <input type="checkbox"/> A- Approved <input checked="" type="checkbox"/> B- Approved as noted <input type="checkbox"/> C- Revise & Resubmit <input type="checkbox"/> R- For information only		
Comments: Refer to attached Atkins comment sheet.		
Below portion for Client use only		
Comments:		
Signed by: _____ Signature: _____ Date: _____		





	Document Title:	DOCUMENT SUBMISSION FORM (DSF)		
	Project Name:	INFRASTRUCTURE AND NETWORKS-84 RBF IN DAMMAM-2	Project Contractor:	
	Project Number:	DAM2-01-010	Project Consultant:	Worley
	Document Reference No:	DAM2-02-010-GB-TS9-3-DSF-CVL-000014-00		

CIVIL & STRUCTURAL

DOCUMENT ISSUED BY		DOCUMENT RECEIVED BY	
Issued By	Engr Ahmed Abdel Fatah	Received By	SULIMAN NOJYFAN
Position/Company	Project Manager	Position/Company	D.C.
Signature		Signature	
Date	11-02-2020	Date	11 FEB 17 02/2020

ATTACHMENTS

source	Manufacturer	Bill of Quantities
	Manual	Method Statement
<input checked="" type="checkbox"/> Sub-contractor	<input checked="" type="checkbox"/> Pre-qualification	Technical Information
Engineering Calculation	Procedure/ Methodology	Bank Warranty
Job Order	Product Data	Letter
Sample	Test Report	Shop drawings

PURPOSE FOR DOCUMENT SUBMISSION

FOR INFORMATION
 FOR REVIEW & APPROVAL
 AS REQUESTED
 OTHER(As Noted)

SUBMITTED DOCUMENTS REFERENCE NUMBERS

#	Document Reference No.	Document Description	Rev.	Hard Copy	Soft Copy
1	GULF CRETE LTD.	Contractor for Water proofing and Insulation Work	00		<input checked="" type="checkbox"/>
2					

RESPONSE STATUS

APPROVED AS SUBMITTED (APP)
 APPROVED AS NOTED (APN)
 REJECTED/RE-SUBMIT (RRS)

COMMENTS

* The Subcontractor is approved for the water proofing and insulation works only.

13/02/2020

RESPONSE ISSUED BY		RESPONSE RECEIVED BY	
Issued By	Bassam Saad	Received By	
Position/Company	CM	Position/Company	
Signature		Signature	
Date	13/02/20	Date	

Note: Approval by the consultant shall not release the contractor of its obligations and liabilities under the contract in case of any discrepancy between the inspected works and final approved designs, the contractor shall carry out the necessary remedies, rectifications, demolishing and reconstruction according to the final approved design without the right to claim extra cost and time

Client:	Consultant:	Contractor:

TECHNICAL DOCUMENTS

Project Name: Resort Core Bulk Grading & Tunnel Construction Works	Project Code: QC00912006
Location: Z00	Date: 08-Apr-2023
Document Title: Pre-Qualification Document of Gulf Crete Ltd. Company for Supply & Installation of PVC Waterproofing Systems (Rev.01).	Ref: QC00912006-SAJ-TEC-PQD-STR-00-Z00-00007
	Rev No: 01

Department:
 Civil
 Structural
 Electrical
 Mechanical
 Authority
 Others

Type:
 Pre-Qualification
 Method Statement
 Material Submittal
 ITP
 Other

Document Description:

- This document contains the Contractor response on Revision 00 comments along with some additional required documents. i.e. CVs, manpower & equipment resources and experience/approval letters.
- Material Manufacturers Prequalification's and Material Technical Submittal will be submitted separately.

Doc. Ref. No.	Title

Enclosure:

Submitted By:	Received By:
Name: Project Manager: Engr. Fami Abuhajleh	Name:
Signature:	Signature:
Date: 08-Apr-2023	Date:

Below portion for Consultant Supervision use only

Status:
 A- Approved
 B- Approved as noted
 C- Revise & Resubmit
 R- For information only

Comments:

- Legal address - No office address provided - Refer to comment no.1
- QC procedure is still generic. Not specific to water proofing- refer to comment no.3
- Previous approvals provided not satisfactory for water proofing for our project. refer to comments no.11

B - Approved with Comments
 Mr Divakaran Ajith - Jacobs Engineering Group Inc.
 Apr 19, 2023, 3:43 PM GMT+3:00

Below portion for Client use only

Comments:

Signed by: _____ Signature: _____ Date: _____





Doc No: DG-DSQ-316-0000-SSA-PQQ-PR-000188
 Revision: 00
 Date: 18 August 2022
 Page: 1 of 2



(DRF) Document Review Form (Submittal)

Part 1 – Issue / Receive / Distribute

Employer: Diriyah Gate Development Authority
 Contractor: Salini Saudi Arabia
 Project: DSQ Package 2 – Super Basement
 Contract/ Work Package: DD-2020-249 / DSQ 316
 Construction Supervisor: AECOM Arabia

Document Type	Document Reference
PREQUALIFICATION	DG-DSQ-316-0000-SSA-PQQ-PR-000188(00)

Document Description	
Title	PREQUALIFICATION- Subcontractor for Epoxy Coating Applicator (Subcon: Gulf Crete Ltd)
Package:	DSQ Package 2
Discipline:	Procurement
Work Location:	Package 2 super basement

List of Attachments (If Any)

Issued By: Contractor
 Name: Marco Tentorio Date: 18 August 2022
 Role: Contractor's Representative
 Signature & Stamp:

Doc No: DG-DSQ-316-0000-SSA-PQQ-PR-000188
 Revision: 00
 Date: 18 August 2022
 Page: 2 of 2



Part 2 – Review and Response

Review Comments (to be completed by the Construction Supervisor/ Consultant)

Approved

Reviewed By: Consultant / Construction Supervisor

Name: _____ Date: _____

Signature: _____

Part 3 – Approval

A. Approved B. Approved with Comments C. Revise and Resubmit D. Rejected

Approved By: Consultant / Construction Supervisor

Name: Bernard Grace
 Role: Resident Engineer
 Signature: 31/08/2022





CERTIFICATION

Consultant 		Client 		Contractor Sharqawi E/M 		Qattuf Al Jazeera 	
PROJECT NO:		LOCATION: RYADH-KSA		PROJECT NAME: KSUEH- BUILDING 04			
MATERIALS SUBMITTAL							
<input checked="" type="checkbox"/> NEW SUBMITTAL <input type="checkbox"/> SUBMITTAL		SUBMITTAL NO: KSUEH-MS-AR-0010		PREV. SUBMITTAL NO:			
		DATE: 19 Feb-17		PREV. SUB AL DATE:			
Submittal reason: <input type="checkbox"/> INFO <input type="checkbox"/> NOTES <input checked="" type="checkbox"/> APPROVAL		Major: <input type="checkbox"/> CV <input checked="" type="checkbox"/> AR <input type="checkbox"/> ST <input type="checkbox"/> AC <input type="checkbox"/> EL <input type="checkbox"/> PL <input type="checkbox"/> OTHER		Attachments: <input checked="" type="checkbox"/> Brochure <input checked="" type="checkbox"/> Tech. Info <input type="checkbox"/> Sample <input checked="" type="checkbox"/> Certificate <input type="checkbox"/> Drawing <input type="checkbox"/> Calculations		Materials/Tools	
Serial	Material Name, Number & Description	Source	Supplier / Manufacturer	Specs. Ref	Code Status		
1	Concrete Repairs	Local	Gulf Crete LTD.				
2	Protective Coating (Epoxy)						
3	Fire Proofing						
4	Water Proofing						
CONTRACTOR		Project Manager					
Procurement Manager		Name: Ayman Shaban		Site Engr. Muhamed Zyadeh			
Name:		Signature:		Signature:			
CONSULTANT NOTES							
<p>*Accepted as a subcontractor and to be provide complete information and materials details and data sheet for review and approval.</p> <p>#Provide warranty Certificate as per project specs and Contract.</p>							
CONSULTANT				STRATEGIC CONSTRUCTION PROGRAM			
Name: Avazag Najjar		Date:		Signature:			
Position: Arch		Signature:		ENG. KHALID FAHD AL-SHAIDDI		General Manager of Strategic Construction Program	
Date: 2/12/2017							
APPROVAL SITUATION							
<input checked="" type="checkbox"/> APPROVED		<input type="checkbox"/> REJECTED		<input type="checkbox"/> NO ACTION			
<input type="checkbox"/> APP. WITH COMMENTS		<input type="checkbox"/>		<input type="checkbox"/>			
<input type="checkbox"/> APP. AS NOTED (RESUBMITTAL REQUIRED)		<input type="checkbox"/>		<input type="checkbox"/>			
INCOMING SIGNATURE:		OUTGOING SIGNATURE:		DATE:			
DATE:		DATE:		DATE:			
Consultant: Original		Contractor: Copy with Stamp		Consultant Site Office: Copy			
(Authority to proceed with work does not relieve the contractor from contractual responsibilities)							

HEMPEL PAINTS (SAUDI ARABIA) W.L.L. Tel: +966 11 407 7039
 P.O. Box 3977, Riyadh 11481 Fax: +966 11 407 8012
 Kingdom of Saudi Arabia Share Capital SR 24,500,000
 C/I 1010018138 Website: hempel.com

شركة اصباغ هيمبل العربية السعودية م.م
 ص.ب. 3977 - الرياض 11481
 رأس المال: ٢٤٥٠٠٠٠٠٠ ريال سعودي
 السجل التجاري: ١٠١٠٠١٨٣٣٨
 الموقع الإلكتروني: hempel.com



Date: 14 NOVEMBER 2017

CERTIFICATION

HEMPEL PAINTS (SAUDI ARABIA) W.L.L. recommends **GULF CRETE LTD.** as an approved Hempel Paints Applicator for the application of its products for both Decorative and Epoxy painting.

Through regular supervision and inspections from the period of two years Hempel Paints has found **GULF CRETE LTD.** be both professional and competent in application of Hempel Paints. They have proven their capability in successfully completing a large number of projects including commercial complexes and single villa projects.

This recommendation is valid for 12 months and will be subject to review on **13 NOVEMBER 2018.**

Furthermore, this recommendation is made by Hempel Paints without prejudice and/or legal liability of whatsoever kind of Hempel Paints.

Yours faithfully,
 For HEMPEL PAINTS (SAUDI ARABIA W.L.L.)

 Ibrahim El Shalkamy
 Branch Manager
 Central Region



CERTIFICATION





APPROVED APPLICATOR CERTIFICATE

GULF CRETE CO.

This is to advise that, **M/S GULF CRETE CO.** has been registered as an approved applicator and the company demonstrated competence in applying the following Master Builders Solutions Saudi Arabia product/s range below:

- » Epoxy & PU Flooring Systems
- » Waterproofing system
- » Concrete Repair

This certificate has been issued upon the request of **GULF CRETE CO.** without having any liability on Master Builders Solutions Saudi Arabia. It is the sole responsibility of **GULF CRETE CO.** to strictly follow the written Method Statement, use proper tools/equipment and maintain good workmanship while applying the products.

This certificate is valid for **6 months** from this date and Master Builders Solutions Saudi Arabia reserve the right to cancel / withdraw the certificate any time if the application of the products is not in line with our written Method Statement. In the occurrence of the above, this certificate become null and void.

For and on behalf of
Master Builders Solutions Saudi Arabia for Manufacturing LLC

Prasad Anandu Warkar
Quality Manager

Date : 19th June 2022
Ref. No. : AA/PW/030/2022

Comments / Replies Legends & Status		Comment Code Legend (for individual comments):		Reply Code Legend:		Open / Closed		
		1 = Action Required; 2 = Note / Advisory / Recommendation		i = Incorporated; ii = Not incorporated for reason stated in reply				
No.	Initial	Page / Section / Sheet	Comment Code	Reviewer Comment	Reply Code	Originator Reply	Reply Status by Reviewer	
1	RB		2	Years of Experience: 20 Years (Operating experience locally)				
2	RB		2	Gulf Crete Ltd. Is previously approved within KAFD Projects (P1.11 & P2.11) - Per Attached Document Approval & Certificate				
3	RB		1	GOSI Certificatein (Attached) is Expired. Key Management and Technical Resources CV are not attach.				
4	RB		2	List of Previous Projects with documented evidences such as List of Partnerships & Valued Costumers, Major projects & References, Customers Approval & Certificates, Project Compliance Certificates, Company Organizational Chart, QHSE Plan & QC Plan are attach.				
5	RB		2	JASARA PQD form is attached. Ministry of Commerce & investment, Chamber of commerce, ISO Certificates, Company Registration, ZAKAT & TAX Certificate, VAT Registration Certificate, Saudization are attached & valid.				
6	RB		2	Final acceptance is subject to JLL approval.				
7	RB		2	Comments are made on the documents as presented. The content remains the responsibility of the author in all respects				
Review Status Code:		B	A-Approved D - No Objection		B - Approved with Comments E - No Objection with Comments		C - Objection	
Reviewer Name(s) / Initials		Supervision Consultant (SC)		Project Management-Construction Management (PMCM)		Programme Management Office (PMO)		Originator
Position		COMMENTS / STATUS RECOMMENDED BY SC		COMMENTS / STATUS RECOMMENDED BY PMCM		COMMENTS / STATUS ADVISED BY PMO		REPLY APPROVED BY
Roger Burnot (RB)		Name: Paul Atkinson		Name: <i>Paul Simon</i>		Name:		Name:
<i>Project Director</i>		Position: Project Director		Position: <i>PM</i>		Position:		Position:
		Signature: <i>RA 6/19/20</i>		Signature: <i>Paul Simon</i>		Signature:		Signature:
		Date:		Date: <i>02-09-2020</i>		Date:		Date:

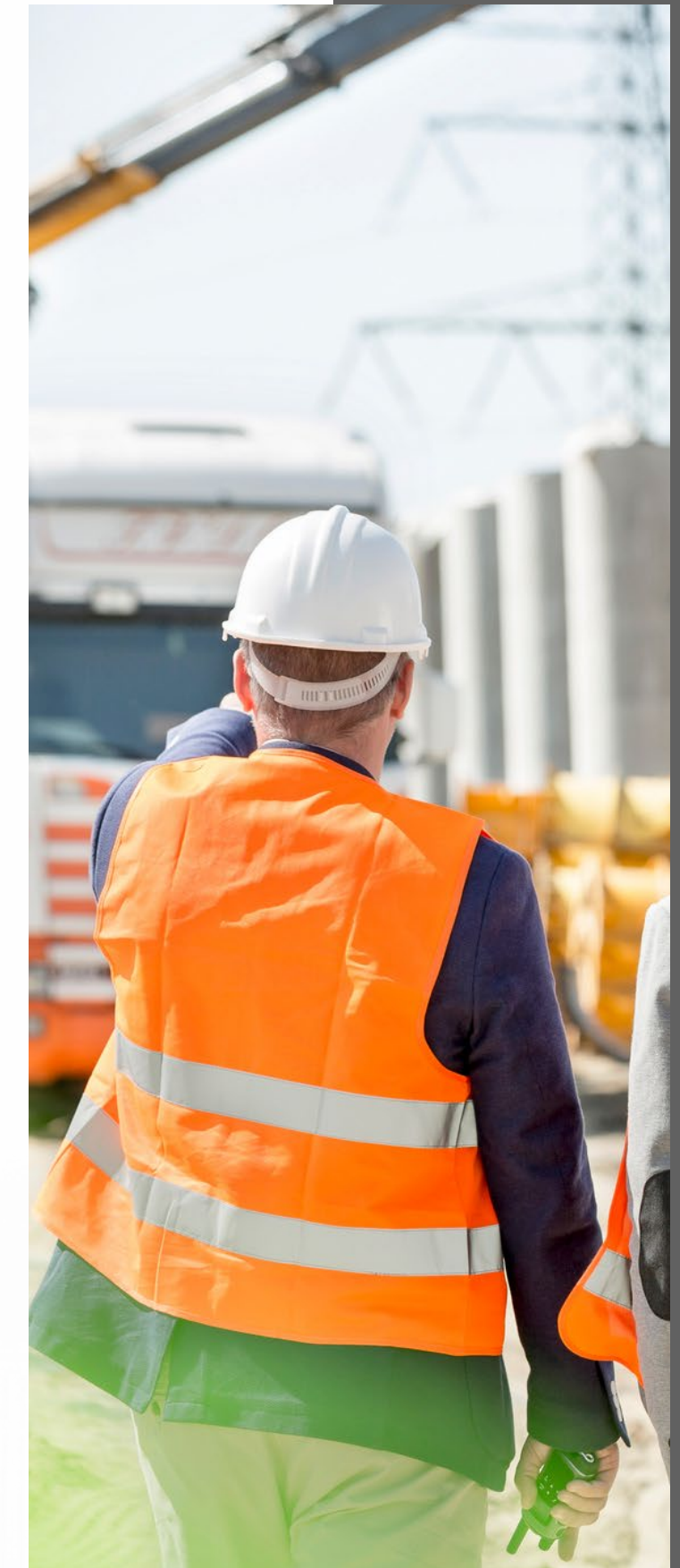

KAFD
Transmittal Form

To: Paul Atkinson (Project Director)	Date: 02/09/2020
Company Name: Dar Al Riyadh	Transmittal no.: KAFD-RY-RIA1-PGEN-SAB-DCM-TRN-06578
Address: KAFD Area Parcel 5.05 7 th Floor, Riyadh, KSA	Project No: CJ01(Parcels 4.05, 5.03, 5.04, 5.05 & 5.06)

Documents transmitted

<input type="checkbox"/> Drawings	<input type="checkbox"/> Contracts	<input type="checkbox"/> Specifications
<input type="checkbox"/> Samples	<input type="checkbox"/> Plans	<input type="checkbox"/> Change Order
<input type="checkbox"/> Procedures	<input checked="" type="checkbox"/> Others(PRE-QUALIFICATION)	

Transmitted for:			Review:		
<input checked="" type="checkbox"/> Approval	<input type="checkbox"/> Information only	<input type="checkbox"/> Tender	<input type="checkbox"/> A - Approved	<input checked="" type="checkbox"/> B - Approved as noted	<input type="checkbox"/> C - Revised and Resubmit
<input type="checkbox"/> Action	<input type="checkbox"/> Design	<input type="checkbox"/> Estimating	<input checked="" type="checkbox"/> B - Approved as noted	<input type="checkbox"/> D - Rejected	<input type="checkbox"/> E - Review not Required
<input type="checkbox"/> Review & Comment	<input type="checkbox"/> Construction	<input type="checkbox"/> Quotation	<input type="checkbox"/> C - Revised and Resubmit	<input type="checkbox"/> D - Rejected	<input type="checkbox"/> E - Review not Required
<input type="checkbox"/> Use	<input type="checkbox"/> Handover	<input type="checkbox"/> Purchase	<input type="checkbox"/> D - Rejected	<input type="checkbox"/> D - Rejected	<input type="checkbox"/> E - Review not Required
<input type="checkbox"/> Submittal	<input type="checkbox"/> Other:	<input type="checkbox"/> Purchase	<input type="checkbox"/> D - Rejected	<input type="checkbox"/> D - Rejected	<input type="checkbox"/> E - Review not Required

Transmitted via:

Hard Copy Soft Copy Hard & Soft Copy

S.N	Doc Ref.	Rev.	Description	No. of Copies
1	KAFD-RY-RIA1-PGEN-SAB-COM-PQD-00052	00	PRE-QUALIFICATION FOR EPOXY APPLICATOR (GULF CRETE LTD)	

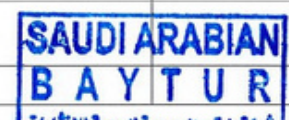

Sender's Name: Halil Ekinci Job title: Project Manager Signature: Date: 02/09/2020

Acknowledgement of receipt (kindly acknowledge receipt and return this sheet to the sender)

Recipient's Name: Job title: Signature: Date: Select date.

Remarks: Refer to attached engineer comments in OCS.

ROGER BURDET 02/09/20

PROJECTS DEPARTMENT- CENTRAL
CIVIL & ELECTROMECHANICAL PROJECTS DIVISION
Address: SEC Head Quaters, Tower : C-2F,Al-Arid

REVIEW OF CONTRACTOR'S SUBMITTAL

Use: C-for Civil, E- for Electrical, M- for Mechanical, and SF- for Safety

Submittal No.:	C 8358/C & EMPD/MAE/21-107.REV01	Date:	02/09/2021G
----------------	----------------------------------	-------	-------------

PROJECT TITLE : Construction of 132/13.8KV S/S 8358 For Misk City Project With 132kV Network In Riyadh Area

PTS NO. : 20CN190 BI NO. : JO NO.:

To : C & EMPD : Division Manager SEC HEAD QUATERS TOWER C-2F, AL-ARID, RIYADH Telephone Number: (011) 80 - 77860	From : (Contractor) Contractor's Name: AL-BABTAIN CONTRACTING CO. Contractor's Address: Al-Ihsa St., Riyadh SA Tel. number: (011) 47-77715 Ext : 1402
---	--

ACCEPTANCE OF THE FOLLOWING SUBMITTAL IS HEREBY REQUESTED

Check Appropriate Box: Drawings / Sketches Materials / Equipment Test Reports/ Calculations Others

FILL-UP APPLICABLE INFORMATION BELOW:

Description : S/S 8358 - METHOD OF STATEMENT FOR SOIL CAVITY INJECTION REV01 - REPLY TO SEC COMMENTS

Reference Specification : SEC LTER # 21/8358-46/12031301 DATED 31/08/2021G

Manufacturer/Supplier :

COMPLYING WITH SCOPE OF WORK AND TECHNICAL SPECIFICATIONS? YES NO
IF "NO" INDICATE DEVIATIONS : (Provide justification and attach supporting documents)

Submitted by : Project Manager (Contractor) Signature : Name : MOHAMED ABU EL-ENEIN Date : 02/09/2021G	Received by : Civil Engineer, C & EMPD Signature : Name : Eng'r Harish Antaram Pawar Date :
--	--

FOR OFFICIAL USE ONLY

SEC-COA/Projects Department has reviewed the above submittal and found it:

ACCEPTABLE
 ACCEPTABLE, AS NOTED
 NOT ACCEPTABLE (RESUBMIT)
 PROVIDE ADDITIONAL INFORMATION
 SEE ATTACHED COMMENTS

Group Leader, C & EMPD
Signature :
Name : Eng'r Mohammed Alkhalidi
SEC Ref. : 21/8358-50/12031301 Dt:08/09/2021

REMARKS : Refer attached for comments

Please use extra sheets if needed.

Received by Signature : (Contractor) Name :

NOTE : Acceptance does not release the Contractor from his responsibilities in performing the work in strict conformance with Contract, Scope of Work and Technical Specifications.



CENTRAL PROJECTS DEPARTMENT
CENTRAL SUBSTATION PROJECTS DIVISION
REVIEW OF CONTRACTOR'S SUBMITTAL

الشركة السعودية للكهرباء
 Saudi Electricity Company
 نعمل بانفاق من اجلكم

Submittal No. 9049/CSPD/SEP003-L-0594-R0 Date: 18 February, 2021

CONTRACT NO.: 4400012943 CONTRACTOR: SEP003
 BUDGET ITEM NO. JOB ORDER NO.: 1-1911052.01
 PROJECT TITLE : CONSTRUCTION OF LAYLA (9049) 380/132 kV BSP

TO : Department Manager, SEC-Central
 2nd Floor, Building-C, Rihana Bint Zaid
 Street, Al Arid Riyadh-KSA Tel : (01) 8077872
 From : (Contractor)
 SEP003 ELECTRIC POWER CONSTRUCTION
 CO.LTD.BRANCH

ACCEPTANCE OF THE FOLLOWING SUBMITTAL IS HEREBY REQUESTED:
 Check in the Appropriate Box: Drawings/Sketches Materials/Equipment Test Reports
 Manual Reminder Weekly/Monthly Report Submittal Others (Specify) _____

FILL-UP APPLICABLE INFORMATION BELOW:
 Description : **Submission of " Epoxy Applicator For Self Levelling Epoxy Coating (SPECIALIST TRADING CORP & CONTRACTING) & (Gulf Crete Ltd.) "** for Substation Layla (9049) 380/132kV BSP.
 Reference Specification : _____
 Manufacturer/Supplier : **S.T.C /GULF CRETE LTD**
 Drawing Number : _____
 Expected Delivery Time : _____

COMPLYING WITH SCOPE OF WORK AND TECHNICAL SPECIFICATIONS? YES No
 IF "NO" INDICATE DEVIATIONS:(Provide justification and attach supporting documents)

Contractor	Project Manager	SEC	Engineer
Signature :	Received by : Civil Team Head	Signature :	Signature : _____
Name : Eng'r. Zhu Hailin	Name : Engr. Nino Celestial Baliguat Baldestamon	Name : _____	Name : _____
Date : 18 / 2 / 2021	Date : 18-FEBRUARY-2021	Date : _____	Date : _____

FOR SEC USE ONLY

SEC HAVE REVIEWED THE ABOVE SUBMITTAL AND FOUND IT:
 A: Acceptable
 B: Acceptable EXCEPT AS NOTED
 C: Not Acceptable (Resubmit)
 See Attached Sheet
 Provide Additional Information

Remarks:
 REFER ATTACHMENT FOR COMMENTS
 ***** NOTHING FOLLOWS*****

Project Department Group Leader Civil
 Signature :
 (Contractor) Received by Signature : _____ || Name : **Eng'r. Mohammed Al-Khaldi** | Name : _____ |
| Ref. No : 21/MAA-2-49-375/12021001 | Date : _____ |
| Date : 21-FEBRUARY-2021 | Date : _____ |

Note: Acceptance does not release the Contractor from his responsibilities in performing the work in strict conformance with Contract, Scope of Work and Technical Specification

A1 -Parcel 5.04 Mixed Use (Office + Retail + Residential)
 King Abdullah Financial District
 King Fahd Rd 11564
 Central Region 13519
 Riyadh
 Riyadh Saudi Arabia

دار الرياض
 DAR AL RIYADH

MAIL TYPE: Workflow Transmittal MAIL NUMBER: DAR-WTRAN-001464 REFERENCE NUMBER: DAR-WTRAN-001464

Final (WF-000387) DAR WF (Baytur) - J01-P504-PQD-Structural Strength work for columns (Retrofitting) and repair (Gulf Crete Ltd) REV-03

From: Mr Paul Atkinson - Dar Al Riyadh Engineering & Architecture
 To (2): Mr Paul Atkinson - Dar Al Riyadh Engineering & Architecture (+1 more...)
 Cc (3): Mr fazal rehman - Jones Lang Lasalle (+2 more...)
 Sent: Wednesday, 26 May 2021 3:07:05 PM AST (GMT +03:00)
 Status: N/A

RECEIVED BY
 26 MAY 2021
 BAYTUR
 KAHD PROJECT

DOCUMENT ATTACHMENTS (1)

File	Document No	Revision	Revision Date	Title	Status
	KAHD-A1-504-SAB-COM-PQD-00001	03	24/05/2021	J01-P504-PQD-Structural Strength work for columns (Retrofitting) and repair (Gulf Crete Ltd)	B - Approved with Comments

ATTRIBUTES
 Attribute 1: ARC - Architect, ELE - Electrical, MEC - Mechanical, MEP - Mechanical & Electrical & Plumbing, SST - Steel Structure, STL - Structural

MESSAGE

Workflow Review History

The attached documents have completed the "DAR WF (Baytur) - J01-P504-PQD-Structural Strength work for columns (Retrofitting) and repair (Gulf Crete Ltd) REV-03" workflow with the following results :

This transmittal was automatically generated.

Doc No	Step	Participant	Review Outcome	Comments
KAHD-A1-504-SAB-COM-PQD-00001	PD	P Atkinson	B - Approved with Comments	No Objection, PQD only, no materials approved.

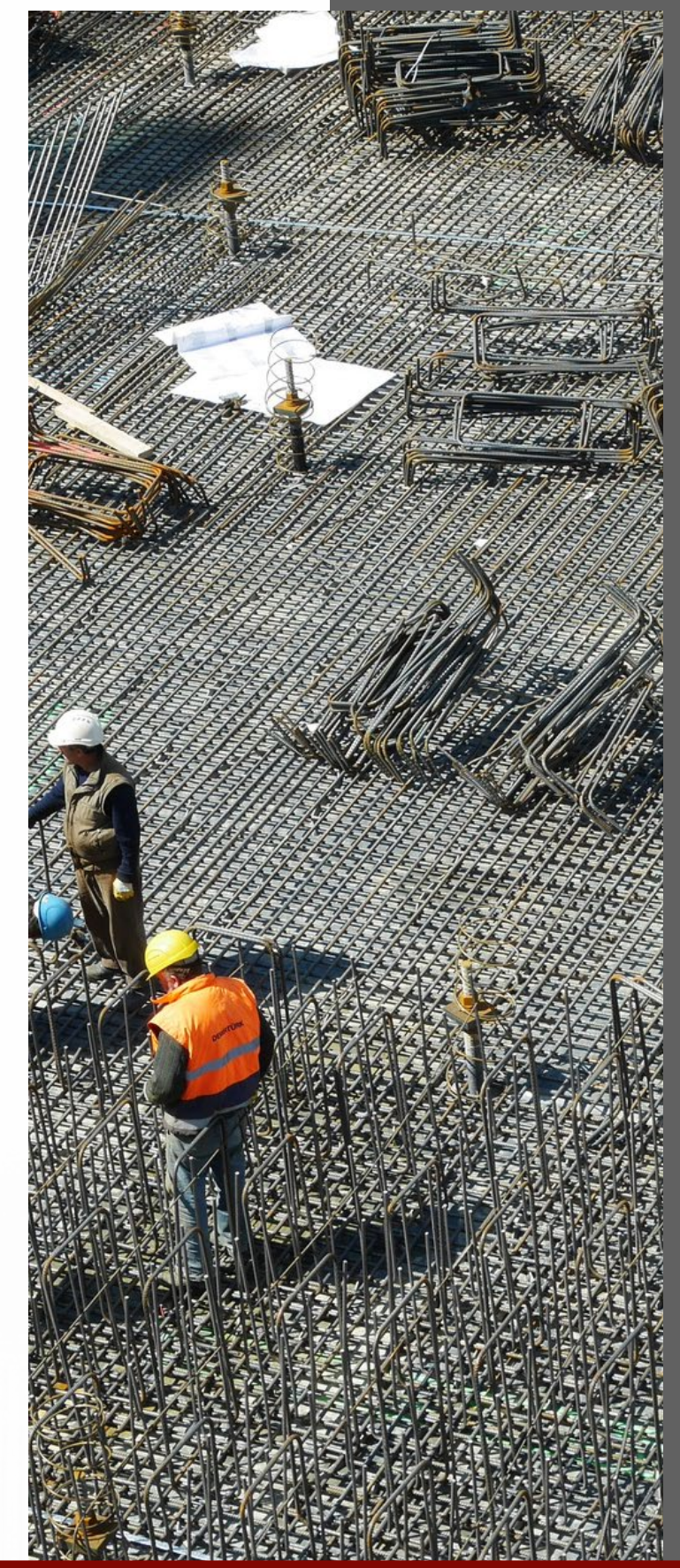

TRANSMITTAL DETAILS
 Program: 7 Construction Supervision
 Project: KAFD-A1-CJ01-GEN-CS-TRN-00814
 Transmittal ID: PQD-Prequalification No.00044-R1
 Subject: and 00052-R0 PGEN for Approval
 Purpose: For Approval
 Issue date: 9/5/2023
 Response due date: 9/20/2023

SENDER
 Issued by: Ahmad, Ahlaq
 Email: aahlaq.ahmad@daralriyadh.com
 Phone (1):
 Phone (2):

Recipient name	Response required	Company	Recipient title	Email
Mohamed Farooq	NO	DAR-AL Riyadh	QA/QC Engineer	Mohamed.Farooq@daralriyadh.com
Paul Atkinson	NO	DAR-AL Riyadh	Project Manager	Paul.Atkinson@daralriyadh.com
Abda Ikader Al-Bakour	YES	JLL	Project Manager	Abdalkader.Bakour@eu.jll.com
Ahmed Batoot	YES	JLL	Project Manager	Ahmed.Batoot@eu.jll.com
Brad Adams	NO	JLL	Construction Director	Brad.Adams@eu.jll.com
David Connolly	NO	JLL	Technical Director	David.Connolly@eu.jll.com
Desai Birju	NO	JLL	Sr. Planner	Birju.Desai@eu.jll.com
Fazal Reman	NO	JLL	Document Controller	Fazal.Rehman@eu.jll.com
Greg Potts	NO	JLL		Greg.Potts@eu.jll.com
Ian Armstrong	YES	JLL	Project Director	Ian.Armstrong@eu.jll.com
JLL KAFD Document Control	NO	JLL	Document Control	JLL.MENAKAFDDocumentControls@eu.jll.com
Mervyn Nicholl	YES	JLL	Delivery Team	Mervyn.Nicholl@eu.jll.com
Ricardo Fachin	YES	JLL	Sr. Project Manager	Ricardo.Fachin@eu.jll.com
Wilus VanZyl	YES	JLL	Associate Director	Wilus.VanZyl@eu.jll.com
Ziad Sinno	YES	JLL	Project Manager	Ziad.Sinno@eu.jll.com

NOTES
 All
 Please find the attached PQD's No 00044-R1 and 00052-R0 for your information and approval as well.
 Regards,
 Ahlaq Ahmad

Item no.	File name	Version	State	Description	Review Code
1	KAFD-RY-RIA1-PGEN-SAB-COM-PQD-00044-R1.pdf	R01	Published	PQD for Alkur Mamariyah Est to Cover Steel and Grating Works	
2	KAFD-RY-RIA1-PGEN-SAB-COM-PQD-00052.pdf	R00	Published	PQD for Epoxy Applicator (Gulf Crete Ltd)	B

Item no.	File name	Version	State	Reference of
1				

GENERAL INFORMATION			Hard Copy Received	
Discipline	Discipline	Document Type	Hard Copy	
PMT	MEP	LTR	Soft Copy (CD/DVD)	
PCM	ELE	DWG		
DCM	CEN	Tech Dec		
BSK	QMS	MOM		
COM	HSE	RPT		
ENG	SHM	WPR		
ARC	ADM	MPR		
Civil	HRM	Other		

FOR RECIPIENT/REVIEWER USE ONLY		
Review Status	No Objection-D	
Approved-A	Incomplete Document to Review	
Approved with Comment-B	No Objection with Comment-E	
Objection C	Accepted for Construction	
	No Review Required	
	Accepted As-Built	

Reviewer Comment
 Refer to OCS sheet

Reviewed By: Ziad Sinno
 Name: Ziad Sinno
 Title: PM
 Signature: [Signature]
 Approved By: [Signature]
 Name:
 Title:
 Signature:



APPROVED APPLICATOR CERTIFICATE

GULF CRETE CO.

This is to advise that, M/S GULF CRETE CO. has been registered as an approved applicator and the company demonstrated competence in applying the following Master Builders Solutions Saudi Arabia product/s range below:

- » Epoxy & PU Flooring Systems
- » Waterproofing system
- » Concrete Repair

This certificate has been issued upon the request of GULF CRETE CO. without having any liability on Master Builders Solutions Saudi Arabia. It is the sole responsibility of GULF CRETE CO. to strictly follow the written Method Statement, use proper tools/equipment and maintain good workmanship while applying the products.

This certificate is valid for 6 months from this date and Master Builders Solutions Saudi Arabia reserve the right to cancel / withdraw the certificate any time if the application of the products is not in line with our written Method Statement. In the occurrence of the above, this certificate become null and void.

For and on behalf of
 Master Builders Solutions Saudi Arabia for Manufacturing LLC

Date : 2nd April 2023
 Ref. No. : AA/PW/075/2023

Prasad Anandu Warkar
 Quality Manager

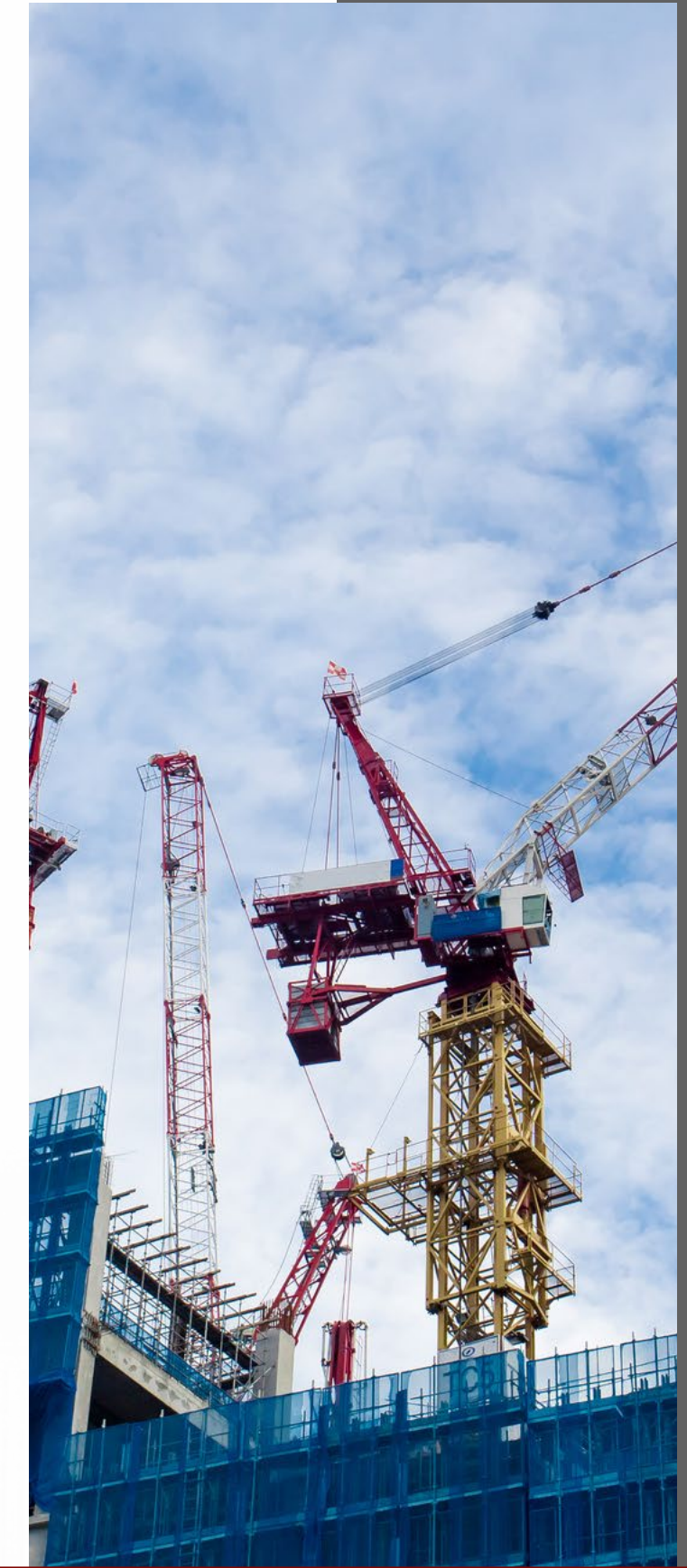

مشروع مركز الملك عبد الله المالي - المنطقة (2)
King Abdullah Financial District Project - Zone (2)

مجموعة بن لادن السعودية
SAUDI BINLADIN GROUP
PUBLIC BUILDINGS & AIRPORTS
بناي العامة والمطارات

Date : June 15, 2015

TO WHOM IT MAY CONCERN

This is to certify that M/S. GULF CRETE Ltd Company executed the epoxy coating work for car park at **King Abdullah Financial District Project** in Parcel 2.11 and we found the work as per required Specification and in good quality.

This certificate has been given to them as per their request.

Thanks & Best regards
For And On Behalf of Saudi Binladin Contracting Group - Dubai Branch

Eng. Naser Aqel Elayan
Zone Manger





شركة ذات مسؤولية محدودة س.ت 1136 - ص.ب 18872 الرياض 11425 - المملكة العربية السعودية - هاتف: 011 4898816 فاكس: 011 4898815
Limited Liability Co. C.R. No.: 081136 - P.O.Box: 18872 - Riyadh 11425 - Saudi Arabia - Tel.: 011 4898816 Fax: 011 4898815
E-mail: secretary.abg@sfidzone2@gmail.com





Dated: 15th June 2015

To whom it may concern,

This is to certify that M/S Gulf Crete is working at Centro Riyadh Hotel project under SCC supervision for water proofing & epoxy coating with the satisfaction of SCC site management.

Moreover, we are satisfied with the method of statement and standard of work done at site & comply with the specification of work.







We wish them all success in future.

Thank you and best regards,



Eng. Nicolas Haddad
SCC Project Manager
Centro Riyadh Hotel project.



							
Client : National Housing Company		PMC : Dar al-handasah		Consultant : Khatib & Alami		General Contractor : Tamimi Global Company Ltd.	
MATERIAL SUBMITTAL							
AR	ME	CV	LA	Submittal No.	M	S	-
ST	FE	QS	OT	Date : 7/13/2020	2	2	1
To: Khatib & Alami				From: Tamimi Global Company Ltd.			
List of Enclosures							
Specs./ BOQ / Drawings Reference		Application for: Roof Insulation / waterproofing (Precast, Fursa, Buildings).					
		Specification Ref. as per project specification (Sec.075700).		<input type="checkbox"/> Copy of Related Drawing (Khatib & Alami) Spec. Ref. No. 075700			
		BOQ Reference(s): MURCIA BOQ		<input type="checkbox"/> Compliance Statement			
		Drawing Ref.:		<input type="checkbox"/> Catalogue			
Specified Material		PU.Foam, Acrylic / Cementitious Coating.		<input checked="" type="checkbox"/> Others (Specify)			
Proposed Material		PU.Foam, Acrylic / Cementitious Coating.		<input type="checkbox"/> Test Certificate			
Manufacturer / Local Supplier		GULF CRETE LTD THE SPECIALIZED CO					
Reasons for Alternative (if any)		شركة التميمي					
Contractor's Remarks:		TAMIMI GLOBAL CO. LTD 2050004970					
Contractor Incoming Signature:		Contractor Outgoing Signature:					
Consultant Comments:		<p>• THE FOLLOWING MATERIAL HAVE BEEN APPROVED: POLYFOAM 20, POLYESTER S, ALYAF.</p> <p>• CALCULATION OF U-VALUE ARE WITHIN SBC 602, AS PROVIDED BY CONTRACTOR.</p> <p>• MOCKUP SAMPLE WITH TEST TO BE DONE PRIOR ANY DELIVERY.</p> <p>• COMPLETE SECTIONS AND DETAILS TO BE SUBMITTED BEFORE.</p> <p>• SUBJECT TO NEGATIVE VARIATION ORDER INCL TO REMOVAL OF SBS WATERPROOF MEMBRANE. NEGATIVE ORDER TO BE FINALIZED PRIOR ANY INVOICING.</p>					
For K&A Signature:		Date: 16/7/20					
ACTION CODE:		<input type="checkbox"/> A = Approved <input checked="" type="checkbox"/> B = Approved as noted <input type="checkbox"/> C = Resubmit as Noted <input type="checkbox"/> D = Disapproved <input type="checkbox"/> E = No action taken <input type="checkbox"/> F = Retained for Info.					

							
Client : National Housing Company		PMC : Dar al-handasah		Consultant : Khatib & Alami		General Contractor : Tamimi Global Company Ltd.	
SUPPLIER PRE-QUALIFICATION							
AR	ME	CV	LA	Submittal No.	S	P	-
ST	EE	QS	OT	Date : 7/13/2020	1	2	4
To: Khatib & Alami				From: Tamimi Global Company Ltd.			
Supplier Description				Attachments			
Name:		GULF CRETE LTD THE SPECIALIZED CO.		<input checked="" type="checkbox"/> Company Profile			
Telephone No.:		0114655034		<input checked="" type="checkbox"/> Valid Commercial Registration Certificate			
Address:		RIYADH-KSA		<input checked="" type="checkbox"/> Valid Membership of Chamber of Commerce			
Person in Charge and His Mobile No:		599281826		<input checked="" type="checkbox"/> Valid VAT Registration Certificate			
Supplier's Qualifying Log:				<input checked="" type="checkbox"/> Valid Zakat & Tax Certificate			
Years of Experience (In Total):		20 YEARS		<input checked="" type="checkbox"/> Valid General Organization of Social Insurance			
Years of Experience In Saudi Arabia:		20 YEARS		<input checked="" type="checkbox"/> Valid Saudization Certificate			
				<input type="checkbox"/> Valid Contractor Classification Certificate			
				<input type="checkbox"/> Valid SASO Certificate			
				<input checked="" type="checkbox"/> Authorized Signatory of Responsible Person			
Material to Supply: WATERPROOFING, INSULATION, FIREPROOFING, CONCRETE REPAIRS, AND FLOOR COATINGS							
Approval of Supplier does not relieve contractor of his responsibilities under contract's terms.							
Contractor's Remarks:		<p>Hardcopy of company profil (3) , cd -softcopy (3)</p> <p>TAMIMI GLOBAL CO. LTD 2050004970</p>					
Contractor Incoming Signature:		Contractor Outgoing Signature:					
Consultant Comments:		<p>MURCIA HOUSING PROJECT</p> <p>• SUPPLIER APPROVED TO PROVIDE THE ABOVE MENTIONED MATERIAL.</p> <p>• MATERIAL TO BE PROVIDED AND AREA OF APPLICATION IS SUBJECT TO CONSULTANT APPROVAL.</p> <p>• ANY MISSING CERTIFICATE, OR OUTDATED CERTIFICATE TO BE PROVIDED</p>					
For K&A Signature:		Date: 14/7/20					
ACTION CODE:		<input type="checkbox"/> A = Approved <input checked="" type="checkbox"/> B = Approved as noted <input type="checkbox"/> C = Resubmit as Noted <input type="checkbox"/> D = Disapproved <input type="checkbox"/> E = No action taken <input type="checkbox"/> F = Retained for Info.					
NOTE: The Client - National Housing Company (NHC) has the authority to approve/disapprove the supplier without any objection from all sides.							



Date and Time Information

Date & Time of Print: 09/08/2021 14:08:21 – Time Zone: Arabia Time

Organisation Details

Organisation Name (English input will be accepted only)	Gulf Crete Ltd
Trade Market Name (English input will be accepted only)	Construction, Maintenance
Address	Riyadh
Country	SAUDI ARABIA
Region	Riyadh / منطقة الرياض
ZIP/Postal Code	11323
Main Organisation Phone Number	0114655034
Organisation Fax Number	0112939553
Organisation Email Address	gulfcrite@outlook.com
Web site	www.gulfcrite.com

Organisation Legal Structure

Private Limited or Limited Liability Company (شركة ذات مسؤولية محدودة)

Company Registration Number	1010419075
VAT Number	301099174300003

User Details

Title	Mr.
First Name	
Last Name	
Telephone	0114655034
Mobile	+966599281826
Email	shahrukh@gulfcrite.com
Username	shahrukh@gulfcrite.com
Preferred Language	English (UK)
Time Zone	(GMT + 3:00) Kuwait, Riyadh, Doha, Manama

Contact List

Last Name	First Name	Email	Phone Number
1		shahrukh@gulfcrite.com	0114655034

Registration Date

30/06/2020

List of Forms

No Forms found

Path	Category Title	Last Modification Date	Status Summary	Assessments Present
1	Status Completed MAINTENANCE AND REPAIR FACILITY	11/01/2021	Assessment Status not visible	0
2	Status Completed ADHESIVE AND SEALANTS	11/01/2021	Assessment Status not visible	1
3	Status Completed INTERIOR FINISHING	11/01/2021	Assessment Status not visible	1
4	Status Completed OPERATION AND MAINTINANCE	11/01/2021	Assessment Status not visible	1
5	Status Completed FIRE FIGHTING SYSTEMS	11/01/2021	Assessment Status not visible	1
6	Status Completed CARGO HANDLING FACILITIES	11/01/2021	Assessment Status not visible	1
7	Status Completed TERMINAL	11/01/2021	Assessment Status not visible	1
8	Status Completed CAR PARKING	11/01/2021	Assessment Status not visible	1
9	Status Completed CIVIL WORKS	11/01/2021	Assessment Status not visible	1
10	Status Completed ROOFING MATERIALS	01/07/2020	Assessment Status not visible	1
11	Status Completed PAINTS & COATING SUPPLIES	01/07/2020	Assessment Status not visible	1
12	Status Completed METAL/STEEL STRUCTURE	01/07/2020	Assessment Status not visible	1

Path	Title	Date	Status Summary	Present
13	Status Completed AIRPORTS CONTRACTING	01/07/2020	Assessment Status not visible	1
14	Status Completed MAIN,MINOR SEWERAGE, NETWORK	11/01/2021	Assessment Status not visible	1
15	Status Completed CAR PARKING,OTHER SHADES STRCT	01/07/2020	Assessment Status not visible	1
16	Status Completed HANGERS,WAREHOUSE WORKS	01/07/2020	Assessment Status not visible	1
17	Status Completed MAIN ROADS,STREETS RELATED WRK	11/01/2021	Assessment Status not visible	1
18	Status Completed COOLANT AND ADDITIVES	01/07/2020	Assessment Status not visible	1
19	Status Completed ADHESIVE AND SEALANTS	01/07/2020	Assessment Status not visible	1
20	Status Completed INFRASTRUCTURE,BUILDING WORKS	01/07/2020	Assessment Status not visible	1
21	Status Completed GEOPHYSICAL	11/01/2021	Assessment Status not visible	1
22	Status Completed CAR PARKING SYSTEM	01/07/2020	Assessment Status not visible	1
23	Status Completed JOINTING,PACKING	11/01/2021	Assessment Status not visible	1
24	Status Completed VESSELS AND TANKS	01/07/2020	Assessment Status not visible	1
25	Status Completed DIGGING AND PILING WORKS	11/01/2021	Assessment Status not visible	1
26	Status Completed RESIDENT ENGINEERING SERVICES	11/01/2021	Assessment Status not visible	1
27	Status Completed MASONRY,STONE WORK TILE	01/07/2020	Assessment Status not visible	1
28	Status Completed MAINTENANCE SERVICES	11/01/2021	Assessment Status not visible	1
29	Status Completed MATERIALS	01/07/2020	Assessment Status not visible	1
30	Status Completed CLADDING WORKS	01/07/2020	Assessment Status not visible	1
31	Status Completed FORWARDING FACILITY	11/01/2021	Assessment Status not visible	1
32	Status Completed GENERAL WORKS	01/07/2020	Assessment Status not visible	1
33	Status Completed INDUSTRIAL WORKS	01/07/2020	Assessment Status not visible	1
34	Status Completed ROAD MARKINGS	01/07/2020	Assessment Status not visible	1
35	Status Completed EXTERIOR RENOVATION WORKS	11/01/2021	Assessment Status not visible	1
36	Status Completed INTERIOR RENOVATION WORKS	11/01/2021	Assessment Status not visible	1
37	Status Completed FIRE SUPPRESSION SYSTEMS	11/01/2021	Assessment Status not visible	1
38	Status Completed CARPET AND FLOORING	11/01/2021	Assessment Status not visible	1
39	Status Completed TOPOGRAPHIC & OTHER	11/01/2021	Assessment Status not visible	1
40	Status Completed PAINT	01/07/2020	Assessment Status not visible	0
41	Status Completed SEALANT	11/01/2021	Assessment Status not visible	0
42	Status Completed SEALER	11/01/2021	Assessment Status not visible	0
43	Status Completed SEAL	11/01/2021	Assessment Status not visible	0
44	Status Completed JOINT	11/01/2021	Assessment Status not visible	0
45	Status Completed INSULATION	01/07/2020	Assessment Status not visible	0

No Segmentation Assessment found

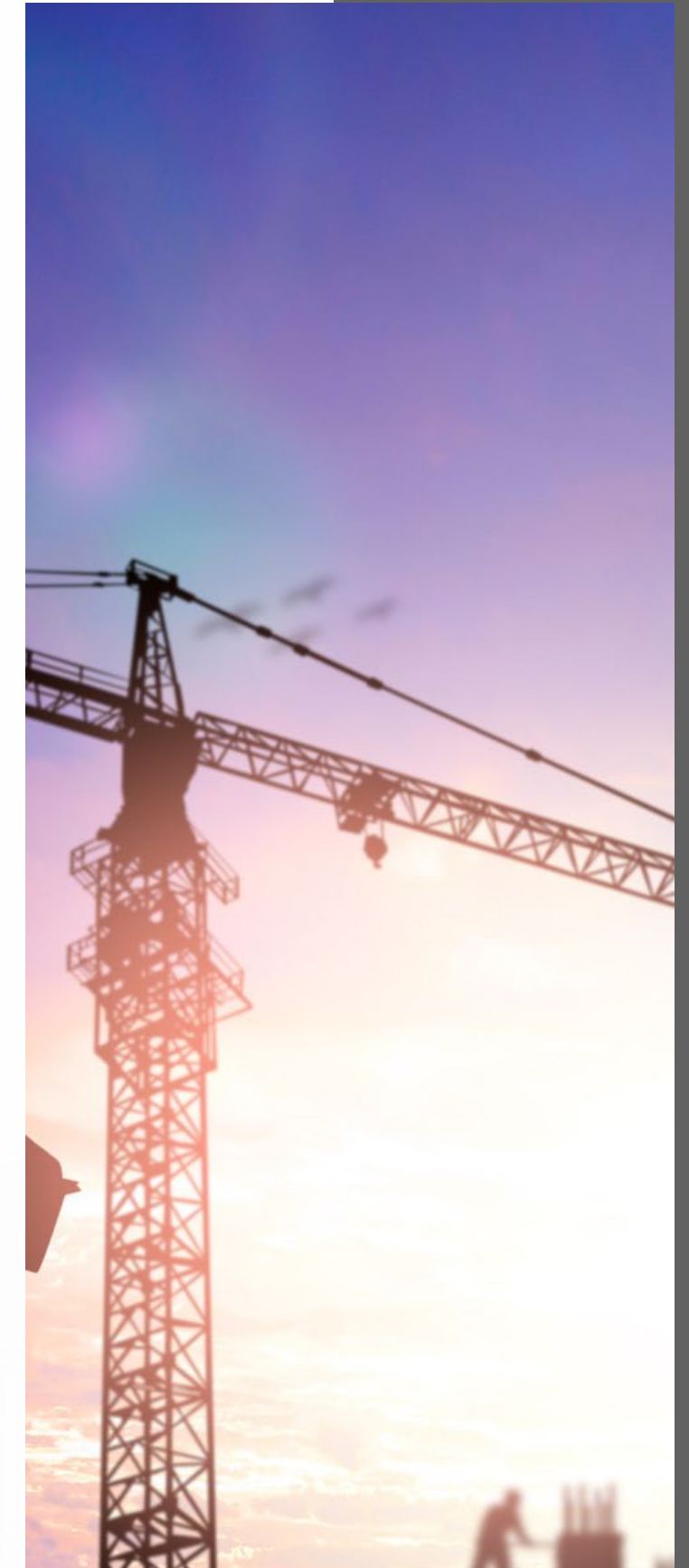

CERTIFICATION



GULF CRETE LTD.
IS AN
APPROVED APPLICATOR
OF FLOWCRETE PRODUCTS

Deckshield, Isocrete, Flowfresh, Flowfast, Mondeco and Other Epoxy Systems but not limited to coatings, Screeds and Multi-Layer Systems

For the period of: 01/01/2019 To: 31/12/2019

Signed:

Mayur Agarwal | Regional Sales Manager – StonCor ME Flooring Business

StonCor Middle East LLC
PO BOX 3034
Al Quoz Industrial Area Dubai UAE
Tel: +971 4 347 0460 | Fax: +971 4 347 0242
Email: uae@flowcrete.com

Flowcrete in the Middle East is manufactured & sold by StonCor Middle East LLC under License from Flowcrete UK.



www.flowcrete.ae





CERTIFICATION

CENTRO HOTEL, RIYADH
Document Submittal

TITLE: PQD OF GULF CRETE LTD. CONTRACTING COMPANY **SUBMITTAL NO.:** DS-PQD-CR-014-AR-29

TO: Mr : Khatib and Alami **REV. NO.:** 00

FROM: **DATE:** 28-10-2014

ATTN: Engr. Safwan Al Futaieh **ORIG. REF:**

TYPE OF SUBMITTAL

SD - Shop Drawing SMP - Samples ABD - As Built Drawings

SCE - Program / Schedule CRT - Certification, Verification OMM - Operating & Maintenance Manuals

MST - Method Statement PQD - Pre-Qualification QPP - Quality Plans & Procedures

MUP - Mock Ups & QC Panels TST - Test Reports MPD - Product & Materials Data

OTH - Others:

SUBMITTAL DISCIPLINE & DESCRIPTION

C-Civil S-Structural A-Architectural E-Electrical M-Mechanical G-General O-Coordination

I-Interior Design L-Landscape F-Fit-Out Attachments: 01 (PQD) (PQD)

SPECIFICATION & BOQ REF: _____ **Location / Use:** _____

SUBMITTED FOR:

A-Approval R-Review & Comments Q-As Requested I-Information / Records Only N-Action O-Others

Submitted By Contractor's Rep.: Engr. NICOLAS HADDAD **Signature:** _____

PROJECT MANAGEMENT REVIEW (If Required)

Name: _____ **Signature:** _____ **Date:** _____

CLIENT'S COMMENTS (Optional)

Name: _____ **Signature:** _____ **Date:** _____

SUPERVISION CONSULTANT'S COMMENTS

A-Approved B-Approved with Comments, When May Proceed - Incorporate Comments & Resubmit Within _____ Days C- Reviewed With Comments, Revise / Resubmit D- Rejected

Comments:

- Must be adhered to the contractual documents, specifications and B.O.Q

- Must be qualified and certified for the application of the approval materials (all documents and certificates must be submitted for consultant review)

- certificate of warranty (at least 5 years) must be sent to consultant.

- The company and Scc are responsible for the perfect application of these materials with providing epoxy paint. The company must check, rectify and complete all preparation works for any area before start these materials.

DATE RECEIVED: _____ **DATE RETURNED:** 28/10/14

SUPERVISION CONSULTANT'S SIGNATURE

For & on behalf of Khatib & Alami (Project Manager)

Name: Engr. Safwan Al Futaieh **Signature:** _____ **Date:** _____

CERTIFICATION

Pre-qualification Submittal

TRADE : CIVIL /STRUCTURAL **Submittal No.:** 120-B-PRQ-S-83 **Revision No.:** 0

Specs. Code & Ref.: 09-900IE **B.O.Q Code Ref.:** 5-1 **Building No.:** 120 **Date Submitted:** 13-09-15

Item no.: _____ **Description:** _____ **Details:** _____

Submitted for:

Approval

Information

Coordination

Review

GULF CRETE LTD. CONTRACTING COMPANY

www.Gulfcrete@outlook.com **Trade:** Structural

Tel: 011-4655034 **Architectural**

MEP Dept.

Material Dept.

Technical Dept.

QA/QC Dept.

Edc. Control

Attachment: Certificates

Technical Brochure

Manufacturer's Data & Specs.

Shop Drawings

Sample

Catalogue

Company Profile

As-Built Drawings

Warranty

Others (Specify) _____

Prepared by: Engr. Hassan Shehata **Checked by:** Engr. Mohamed Eleawa **Noted by:** Engr. Mahmoud Abdul Azim

Senior QA/QC Engineer Acting QA/QC Manager Construction Manager

FOR CONSULTANT USE ONLY: Received by: _____

Remarks: لا مانع من تقديم شروط طبقا لتوقيت المالك
 @ بعد تقديم طلبية للتوريد لا تعاد
 @ بعد تسليم الكميات المقترحة من المورد يتم المضي في تنفيذها لا تعاد
 @ يجب التأكد طبقا لتوقيتات المورد والمواد المطلوبة المسجلة ونفقات الاستلام
 @ يجب مراعاة حوامل الأمتار والبريد أثناء التنفيذ طبقا لخطط الأمتار والسلامة المرصوفة بتفصيل

ACTION taken:

Project Manager: Engr. Ashraf Tantawy Resident Engineer: _____

Approved

Approved with comments

Approved with comments (Resubmit)

Rejected

OWNER **CONSULTANT** **CONTRACTOR**

Contractor's Signature: _____ **Date:** _____





CERTIFICATION



شركة بي إي إس إف السعودية - نواد البناء المحدودة
 برج العمال الطابق رقم 11
 طريق الملك سعود القنطرة، الطويران 31221
 ص.ب 1884 الخبر 31952 - المملكة العربية السعودية
 Saudi BASF For Building Materials Co. Ltd.
 Al-Othman Business Tower 14th Floor
 King Saud Road, Al-Qashshah, Dhahran 34232
 P.O. Box 1884, Al-Khobar 31952

26th February 2017
 Ref:JT/L001/26022017

PRE – QUALIFICATION CERTIFICATE OF CONFIRMITY

This is to acknowledge that **M/S Gulf Crete Ltd. Contracting Company**. Has submitted company profile and other relevant documents to SAUDI BASF, For Building Materials Co Ltd for authorized applicator approval purpose. Hereby we are certifying that they are under review and authorized to apply our products as below.

- WATERPROOFING SYSTEMS
- Epoxy and PU flooring system
- Concrete Repair

Further to their team of supervisor had maintained good quality work. Hence, they are prequalified applicators to the Saudi BASF range of products as described above.

The pre-qualification is valid for one year from this date and subject to remain under constant monitoring for using Saudi BASF – The Chemical Company products. This pre-qualification can be withdrawn, if the quality of application is not to BASF's satisfaction.

For and on Behalf of
 Saudi BASF Co.Ltd.

Jignesh Thakkar.
 Technical Manager

شركة بي إي إس إف السعودية نواد البناء المحدودة
 Saudi BASF
 for Building Mts. Co. Ltd.
 قسم المختبرات والجودة
 Technical Department

المكتب الرئيسي:
 هاتف: +966 13 853 8600, 13 812 1140
 فاكس: +966 13 832 8671, 13 812 1822
 www.master-builders-solutions.sa
 enquiry@saudi@basf.com



شركة ذات مسئولية محدودة في المملكة العربية السعودية رأس المال المدفوع 11 مليون ريال سجل تجاري رقم 2000007920
 المكتب المسجل طريق رقم 88 المنطقة الصناعية الثالثة، الدمام، المملكة العربية السعودية هاتف: +966 13 812 1140 فاكس: +966 13 812 1822
 A private Company Incorporated with limited liability in the KSA, Paid Up Share Capital SR 11 Million, Commercial Registration No. 2000007920
 Registered Office, Street No 58, Dammam 2nd Industrial Area, Saudi Arabia, Tel : +966 13 812 1231. Fax : +966 13 812 3259



Ref : AY/06/22

Date: June 21, 2022.

TO WHOM IT MAY CONCERN

This is to certify that **M/s. Gulferete** have considered as our certified and approved applicator for following Fosam Products' Range as below:

- Concrete Repair.
- Protective Coatings.
- Industrial Flooring.
- Joint Sealants.

This certificate is issued upon their request without any liabilities on Fosam Company Limited and valid for six months from the date of issuance of this certificate.

Yours sincerely,
 For **Fosam Company Limited**



Fosam Company Limited
 Head Office
 PO Box 11081
 Jeddah – 21452
 Saudi Arabia
 C.R. No 31273
 Paid up Capital: SR3,000,000
 www.fosroc.com

فوسام المحدودة
 صندوق بريد 11081
 جدة - 21452
 المملكة العربية السعودية
 رقم التسجيل 31273
 رأس المال المدفوع: 3,000,000 ريال سعودي
 www.fosroc.com





CERTIFICATION



شركة دي سي بي السعودية

Date: 22nd November 2014

TO WHOM IT MAY CONCERN

This is to certify that **M/s Gulf Crete Ltd.** is our approved and certified applicator for all **DCP Saudi Company** Products for following ranges:

- Waterproofing system
- Joint Sealant
- Protective coating for concrete and masonry
- Epoxy Flooring
- Concrete repair
- Injection

This certificate is issued upon their request and without any liabilities on **DCP Saudi Company**, and valid for Six months from the date of issuance of this certificate.

Yours Sincerely,



For
DCP Saudi Co.

DCP Saudi
PO Box 66241 Riyadh 11576
Kingdom of Saudi Arabia
Tel. + 966 11 481 2003
Fax. + 966 11 279 2059
Info.saudi@dcp-ltd.com
www.dcp-ltd.com



expertise quality full range

Capital Paid: 1000000 S.R CR. # 1010267930 Licence: 217074 ٢١٧٠٧٤ رقم الترخيص ١٠١٠٢٦٧٩٣٠ ريال سعودي ١٠٠٠٠٠٠ رأس المال المدفوع



CERTIFICATION

CERTIFICATE

FOR RECOMMENDED SIKA APPLICATORS

This is to certify that

GULF CRETE CONTRACTING

Has successfully executed many Projects after having passed the application training of various Sika systems and is Recommended Sika Applicator for

Concrete repair and protection, Waterproofing (PVC membranes loose laid and full compartment system), Cementitious, Resins, Combiflex range), Joint Sealants and Industrial flooring.

This comprehensive training consisted of practical instructions about proper storage, preparation and application of Sika products.

The recommended applicator has been provided with the relevant Sika Product Data Sheets and all other technical documentation.
This confirmation is valid until the date of expiry below and may be renewed subject to the Recommended Applicator successfully completing any training courses required by Sika. The Recommended Applicator is responsible for ensuring full compliance by its employees with Sika's guidelines, training instructions and any other requirements of third parties.
Sika is not responsible for any loss or damage suffered by any third party as a result of any acts or omissions of the Recommended Applicator arising in anyway, including but not limited to breach of contract, misrepresentation, failure to comply with applicable laws or any other tort including negligence.

Sika Saudi Arabia,

Issuing Date: January 01, 2016

Expiry Date: December 31, 2016



Shehadeh Salman
T.M Waterproofing Manager
Central Region
Sika Saudi Arabia



Emad Al Asqar
Sr. Sales Manager
Central Region
Sika Saudi Arabia

This Recommendation does not assume responsibility for the correct storage, mixing or use of these Products. Sika shall not be liable for damage to persons or property, loss of business or profit or any other direct, indirect, special or consequential damage as caused by the Recommended Applicator. Sika shall also not be responsible for use of these Products in a manner to infringe on any patent or other intellectual property rights held by others. Sika's liability is limited to the quality only of the supplied material. Any failures due to wrong application or storage not in accordance with the given guidelines as stated on the latest Technical Data Sheets, as well as structure or mechanical failures are excluded herein.

BUILDING TRUST







CERTIFICATION



constructive solutions

Ref : KR/0513/05
Date : 22nd November 2014

TO WHOM IT MAY CONCERN

This is to certify that **M/s. Gulf Crete LTD.** is our approved and certified applicators for all Fosam Products for the following range of applications:

- Joint sealing works.
- Specialized protective coating for concrete and masonry.
- Epoxy Flooring
- Concrete Repair

This certificate is issued upon their request and without any liabilities on Fosam Company Limited and valid for three months from the date of issuance of this certificate.

Yours sincerely,
For **Fosam Company Limited**

Kareem Rabayah
Area Sales Manager-Central Region
Mobile: 0553829272



Fosam Company Limited
Riyadh Office
P.O. Box 50391
Riyadh - 11523
C.R. No. 31273
Paid up Capital: SR 3,000,000
www.fosroc.com

Registered Office: Building No.153, Takassul Road, North Maafer

Telephone: 00 966 1 482 8303 Fax: 00 966 1 482 7562 e-mail: fosam_riyadh@fosroc.com



CERTIFICATION

Sika Saudi Arabia Co. Ltd.

شركة سيكا العربية السعودية المحدودة

CERTIFICATE

This is to confirm that **Gulf Crete LTD Co.**
P O Box 20647
Riyadh 11465
Is an approved applicator for the following applications of Sika®-Products.
PVC Membrane, Cementitious & Epoxy Waterproofing

The Approved Applicator **Gulf Crete**, has received practical training in the proper storing, preparation and application of the Sika®-Products.

The approved Applicator is aware of the relevant Sika® Product Data Sheets and all other technical documentation.

This Confirmation is valid for one year from its date of issue and may be renewed subject to the Approved Applicator successfully completing any training courses required by Sika. Sika is not responsible for the Approved Applicator's compliance with Sika's guidelines or training instructions or any other requirements of third parties. Sika is not liable for any acts or omissions of the Approved Applicator arising in any way, including, but not limited to, any breach of contract; or any distort (including negligence); or any breach of statutory duty.

THIS CERTIFICATE IS VALID FOR THE PERIOD 01/06/14 TO 01/06/2015

Sincerely,

Emad Al Ashqar,
Senior Sales Manager,
Sika Saudi Arabia,
Riyadh,
Mobile # 0505 363 569





Jeddah
P. O. Box 112356
Jeddah 21371
Saudi Arabia
Tel: +966-2- 8927979
Fax: +966-2- 8921272
C.R. No: 4082083496
sika.jeddah@sika.com

Dammam
P.O.Box 74577
Dammam 31952
Saudi Arabia
Tel: +966-3-8472448
Fax: +966-3-8471763
sika.dammam@sika.com

Riyadh
P.O.Box 58647
Riyadh 11583
Saudi Arabia
Tel: +966-8-11102220
Fax: +966-8-11102281
sika.riyadh@sika.com

Innovation & Consistency | since 1910





CERTIFICATION

CONSULTANT Omrania	CLIENT مركز الملك سلمان للإيواء King Salman Center for Disability Research Autism Screening Program	CONTRACTOR STRATEGIC CONSTRUCTION PROGRAM SHARQAWI ELECTRO-MECHANICAL COMPANY
PROJECT Radisson Blu Hotel/Furnished Apartments DQ, Riyadh		
SUB-CONTRACTOR PREQUALIFICATION SUBMITTAL		
Ref No: C P Q - A 1 4 1	R D	Date: 26 OCT 2015
<input checked="" type="checkbox"/> New Submittal <input type="checkbox"/> Resubmittal		
Submittal reason: <input type="checkbox"/> INFO <input type="checkbox"/> NOTES <input checked="" type="checkbox"/> APPROVAL Major: <input type="checkbox"/> CV <input checked="" type="checkbox"/> AR <input type="checkbox"/> ST <input type="checkbox"/> AC <input type="checkbox"/> EL <input type="checkbox"/> PL <input type="checkbox"/> OTHER		
Attachments: <input checked="" type="checkbox"/> Brochure <input checked="" type="checkbox"/> Tech. Info <input checked="" type="checkbox"/> Sample <input checked="" type="checkbox"/> Certificate <input type="checkbox"/> Drawing <input type="checkbox"/> Calculations		
Materials/Tools		
Serial	Subcontractor Name, Number & Description	Source Supplier / Manufacturer Specs.Ref Code Status
1	GULF CRETE LTD	KSA APPLICATOR FOR EPOXY COATING B
2		
3		
4		
5		
6		
PREQUALIFICATION FOR (GULF CRETE LTD.) EPOXY APPLICATION KSA 2+ CD Description: (Manufacturer, Model, Type, Size, Colour, etc.) <input type="checkbox"/> Catalogue <input type="checkbox"/> Drawing <input type="checkbox"/> Sample <input type="checkbox"/> Calculation <input checked="" type="checkbox"/> Document		
Having checked this submittal, we certify that it conforms to the requirements of the contract documents in all respects, except as otherwise indicated herein. Material Engineer Name & Signature: _____ Project Manager Name & Signature: _____ Received by: _____ Date: _____ Name & Signature of Consultant: _____		
Remarks / Comments: - The prequalification of sub-contractor GULF CRETE LTD. "epoxy applicator" is approved. - Mock-up sample as per contract is required for final approval. RECEIVED 10 NOV 2015		
Status: <input checked="" type="checkbox"/> Approved <input type="checkbox"/> Approved as noted <input type="checkbox"/> Rejected - Resubmit <input type="checkbox"/> Rejected - Resubmit <input type="checkbox"/> No Action		
Engineer: _____ Date: 05.11.2015	Project Manager: _____ Date: _____	Consultant Head Office: _____ Date: _____

CERTIFICATION

Consultant Omrania	Owner King Saud University	Contractor Sharqawi Electro-Mechanical Company Sharqawi Co.
PROJECT NO: KSUE - BUILDING I No 8		LOCATION: Internal and External
SUBCONTRACTOR SUBMITTAL		
<input checked="" type="checkbox"/> NEW SUBMITTAL <input type="checkbox"/> RESUBMITTAL		SUBMITTAL No: AR-08-01 DATE: 07/12/2016 PREV SUBMITTAL NO: PREV SUBMITTAL DATE:
Submittal reason: <input type="checkbox"/> INFO <input type="checkbox"/> NOTES <input checked="" type="checkbox"/> APPROVAL Major: <input type="checkbox"/> CV <input checked="" type="checkbox"/> AR <input type="checkbox"/> ST <input type="checkbox"/> AC <input type="checkbox"/> EL <input type="checkbox"/> PL <input type="checkbox"/> OTHER		
Attachments: <input checked="" type="checkbox"/> Brochure <input checked="" type="checkbox"/> Tech. Info <input checked="" type="checkbox"/> Sample <input checked="" type="checkbox"/> Certificate <input type="checkbox"/> Drawing <input type="checkbox"/> Calculations		
Materials/Tools		
Serial	Subcontractor Name, Number & Description	Source Supplier / Manufacturer Specs.Ref Code Status
1	GULF CRETE LTD	KSA APPLICATOR FOR EPOXY COATING B
2		
3		
4		
5		
6		
CONTRACTOR Procurement Manager Name: _____ Site Engineer: Ammar khaled Name: Ayman Shaban Signature: _____		
CONSULTANT NOTES Approved as epoxy applicator.		
CONSULTANT Name: Mohamed Toth Position: Consultant Engineer Signature: _____ Date: Dec 10 2016		STRATEGIC CONSTRUCTION PROGRAM Signature: _____ ENG. KHALID FAHD AL-SHAIDDI General Manager of Strategic Construction Program
APPROVAL SITUATION <input checked="" type="checkbox"/> APPROVED <input type="checkbox"/> REJECTED <input checked="" type="checkbox"/> APP WITH COMMENTS <input type="checkbox"/> NO ACTION <input type="checkbox"/> APP AS NOTED/RESUBMITTAL REQUIRED		
INCOMING: SIGNATURE: _____ DATE: _____		OUTGOING: SIGNATURE: _____ DATE: _____
Consultant: Original Contractor: Copy with Stamp Consultant Site Office: Copy		





CERTIFICATION

BASF
The Chemical Company

Saudi BASF For Building Materials Co. Ltd. P.O. Box 1884 Al-Khobar 31952 KSA

شركة ام بي سي السعودية
For Building Materials Co. Ltd.
P.O. Box 1884
الخبور 31952
المملكة العربية السعودية
Kingdom of Saudi Arabia

18th OCTOBER 2015
Ref. RUH/AI/0050-15

Head Office
Tel: +966 3 8121140
Fax: +966 3 8121822
www.mot-saudi-arabia.com
inquiry@saudi@basf.com

M/s. GULF CRETE

PRE – QUALIFICATION CERTIFICATE OF CONFORMITY

This is to certify that M/s GULF CRETE had worked with Saudi BASF range of products with the following product groups:

- Epoxy & PU Flooring systems
- Waterproofing systems
- Concrete repair

Their Team of supervisor had so far demonstrated good quality work in application and workmanship. Hence, they are granted as pre-qualified applicator for the Saudi BASF range of products as described above.

This pre-qualification is valid for one year from this date and subject to remain under constant monitoring for using Saudi BASF - The Chemical Company products. This pre-qualification can be withdrawn during the duration of this period, if the quality of application is not to BASF's Standards and Guidelines.

For and on behalf of
Saudi BASF Co. Ltd.

Technical Manager

Saudi BASF
Technical Department

A Private Company incorporated with limited liability in the Kingdom of Saudi Arabia
Paid up Share Capital SR 5.5 Million
Commercial Registration No. 2055027E20
COC Membership No. 476

ANAB



CERTIFICATION

JOTUN SAUDIA

Facsimile

To :- CC	Engr. Fathi AL-Kosa	Date: 02 January 2014 Facsimile :011 4775771 011 4776484
Company :	Gulf Crete Co.	No. of pages : 1
From (Name):	Engr. Yasser Abdul - Hadi	Tel. # 01 2445883
Company :	Jotun Saudia Co. Ltd., Riyadh	Fax # 01 270 9689
Subject :	APPROVED APPLICATOR	

With reference to the above subject we would like to inform you that, M/S Gulf Crete Co., have adequate experience in application our Protective Coatings in Saudia Arabia like floor coating , fire proofing coating & high performance coating. They are one of our approved coating applicators. This certificate does not imply any responsibility on our part for quality control of workmanship or any contractual liabilities.

This is for your kind information.

Thank you & best regards,

Yasser Abdul-Hadi
Area Sales Manager.
Jotun Paints-Riyadh
Mobile : 0559416947
Tel: 01 2445883 – Exit.1610
Fax: 01 270 9689









**CENTRAL PROJECTS DEPARTMENT
CENTRAL SUBSTATION PROJECTS DIVISION
REVIEW OF CONTRACTOR'S SUBMITTAL**

 الشركة السعودية للكهرباء
 Saudi Electricity Company
 نعمل بإتقان من أجلكم

Submittal No.	9049/CSPD/SEP00III-L-0594-R0	Date:	18 February, 2021
CONTRACT NO.:	4400012943	CONTRACTOR:	SEP00III
BUDGET ITEM NO.		JOB ORDER NO.:	1-1911052.01
PROJECT TITLE : CONSTRUCTION OF LAYLA (9049) 380/132 kV BSP			
TO :	Department Manager, SEC-Central 2 nd Floor, Building-C, Rihana Bint Zaid Street, Al Arid Riyadh-KSA Tel : (01) 8077872	From :	(Contractor) SEP00III ELECTRIC POWER CONSTRUCTION CO.LTD.BRANCH
ACCEPTANCE OF THE FOLLOWING SUBMITTAL IS HEREBY REQUESTED:			
Check in the Appropriate Box: <input type="checkbox"/> Drawings/Sketches <input type="checkbox"/> Materials/Equipment <input type="checkbox"/> Test Reports			
<input type="checkbox"/> Manual <input type="checkbox"/> Reminder <input type="checkbox"/> Weekly/Monthly Report <input checked="" type="checkbox"/> Submittal <i>Others (Specify)</i> _____			
FILL-UP APPLICABLE INFORMATION BELOW:			
Description	: Submission of " Epoxy Applicator For Self Levelling Epoxy Coating (SPECIALIST TRADING CORP & CONTRACTING) & (Gulf Crete Ltd.) " for Substation Layla (9049) 380/132kV BSP.		
Reference Specification	:		
Manufacturer/Supplier	: S.T.C /GULF CRETE LTD		
Drawing Number	:		
Expected Delivery Time	:		
COMPLYING WITH SCOPE OF WORK AND TECHNICAL SPECIFICATIONS? <input checked="" type="checkbox"/> YES <input type="checkbox"/> No			
IF "NO" INDICATE DEVIATIONS: (Provide justification and attach supporting documents)			
Contractor	Project Manager	SEC	Engineer
Signature : 		Received by : Civil Team Head	
Name : Eng'r. Zhu Hailin		Signature : 	
Date : 18 / 2 / 2021		Name : Engr. Nino Celestial Baliguat Baldestamon	
		Date : 18-FEBRUARY-2021	
FOR SEC USE ONLY			
SEC HAVE REVIEWED THE ABOVE SUBMITTAL AND FOUND IT:		Remarks:	
<input type="checkbox"/> A: Acceptable <input checked="" type="checkbox"/> B: Acceptable EXCEPT AS NOTED <input type="checkbox"/> C: Not Acceptable (Resubmit) <input checked="" type="checkbox"/> See Attached Sheet <input checked="" type="checkbox"/> Provide Additional Information		REFER ATTACHMENT FOR COMMENTS ***** NOTHING FOLLOWS*****	
Project Department Group Leader Civil		(Contractor)	
Signature : 		Received by	
Name : Eng'r. Mohammed Al-Khaldi		Signature :	
Ref. No : 21/MAA-2-49-375/12021001		Name :	
Date : 21-FEBRUARY-2021		Date :	
Note: Acceptance does not release the Contractor from his responsibilities in performing the work in strict conformance with Contract, Scope of Work and Technical Specification			







SUBCONTRACTOR PREQUALIFICATION SUBMITTAL FORM

Submittal Ref.	KSP-FHJ-INW-CMT-CIV-PQD-0140	Revision	01	Date	14-Marc-2022
Program	King Salman Park				
Project	CP03 Infrastructure Works Phase 1 & O&M Center	Project No.	CP03		
Client	King Salman Park Foundation (KSPF)				
PMO	Saudi Arabian Parsons Ltd. (SAPL)	Contractor	Freyssinet-Haif JV (FHJ)		
PMC	Faithful Gould (FGS)	PMCM			

Discipline Civil Architecture Mechanical Electrical Information Technology
 Landscape Others: C

Sub-Contractor / Supplier Details	Attachments	P / x
Name: GULF CERTE – Riyadh (APPLICATOR)	Chamber of Commerce Membership.	Y
Trade: All type of Water Proofing & Thermal Insulation (APPLICATOR)	Municipality License	Y
Location: Riyadh KSA	Other Licenses (Specify):	Y
Experience (Total No. of Years): 30 Years	Please refer to PQD documents.	
Experience in KSA: 30 Years		
Contact Name: GULF CERTE Head Office Riyadh Mobile Number: 966 599281826 (Shah Rukh Ali Hassan)		
Is the company certified against any quality standard? Yes	Pre-Qualification Doc's (Specify):	Y
Is the company certified against any Health & Safety and Environment standard? Yes	Please refer to PQD documents.	
Subcontractors / Supplier's Proposed Scope of Work in this project		
- Waterproofing & Damp proofing – EPDM – TPO- FPO – POLYUREA - Spray Polyurethane foam Waterproofing - Geosynthetic Engineering - Concrete Repair and Protection – injection work - Building Renovations - Expansion joint – fire proof – decorative and protective epoxy coating - Stamped Concrete - Light Weight Foam Concrete		
	Completion Certificates for Previous Projects	Y

Contractor Signatures & Stamp			
Discipline Engineer	QA/ QC	HSE	Construction Manager
			
 			

Submittal Status:
 A - Approved B - Approved as Noted C - Revise and Resubmit D - Rejected

Engineer's Comments: Complied our previous comments, contractor to keep all the documentation updated.

PMO/Client' Comments:

Name	Signature	Date

Subcontractor Prequalification Submittal Form
KSP-FGS-GEN-PMC-PRO-TEM-xxxx | xx | xx-xx-xxxx





Doc No: DG-DSQ-314-0000-NSM-PQQ-PR-000108
 Revision: 02
 Date: 28 July 2022
 Page: 1 of 2



(DRF) Document Review Form (PQQ)

Part 1 – Issue / Receive / Distribute

Employer : Diriyah Gate Development Authority
Contractor : NESMA & PARTNERS CONT. CO. LTD.
Project : 314-DSQ Tunnels and Gytratory (Under WRR)
Contract/ Work Package : DG1/DG/DSQ/314-DSQ Tunnels and Gytratory (Under WRR)
Construction Supervisor : AECOM

Document Type	Document Reference
Pre-Qualification / Subcontractor	DG-DSQ-314-0000-NSM-PQQ-PR-000108(02)

Document Description	
Title	Prequalification Submittal for M/S GULF CRETE LTD Co. For SHOTCRETE
Package:	DD-2020-280
Discipline:	CE-CIVIL
Work Location:	DG1/DG/DSQ/314-DSQ Tunnels and Gytratory (Under WRR)

List of Attachments (If Any)
 Company profile, Table Content, Organization Chart, List of Projects, Chamber of Commerce Commercial Registrations, Gosi Certificate Saudization Certificate Iso Certificate, Zakat Certificate, Quality & HSE Plan Previous Approval Submittal,

Issued By: Contractor	
Name:	AYHAM BSHARA
Date:	28-07-2022
Role:	PROJECT MANAGER
Signature & Stamp:	

Part 2 – Review and Response

Review Comments (to be completed by the Construction Supervisor/ Consultant)

Classification | Internal

Doc No: DG-DSQ-314-0000-NSM-PQQ-PR-000108
 Revision: 02
 Date: 28 July 2022
 Page: 2 of 2



Reviewed By: Consultant / Construction Supervisor	
Name:	Ebrahim Saif
Date:	01-08-2022
Signature:	

Part 3 – Approval

A. Approved B. Approved with Comments C. Revise and Resubmit D. Rejected

Approved By: Consultant / Construction Supervisor	
Name:	SAMER ODEH
Role:	RESIDENT ENGINEER
Signature:	

Classification | Internal



APPROVED APPLICATOR CERTIFICATE

GULF CRETE CO.

This is to advise that, **M/S GULF CRETE CO.** has been registered as an approved applicator and the company demonstrated competence in applying the following Master Builders Solutions Saudi Arabia product/s range below:

- » Epoxy & PU Flooring Systems
- » Waterproofing system
- » Concrete Repair

This certificate has been issued upon the request of **GULF CRETE CO.** without having any liability on Master Builders Solutions Saudi Arabia. It is the sole responsibility of **GULF CRETE CO.** to strictly follow the written Method Statement, use proper tools/equipment and maintain good workmanship while applying the products.

This certificate is valid for **6 months** from this date and Master Builders Solutions Saudi Arabia reserve the right to cancel / withdraw the certificate any time if the application of the products is not in line with our written Method Statement. In the occurrence of the above, this certificate become null and void.

For and on behalf of
Master Builders Solutions Saudi Arabia for Manufacturing LLC

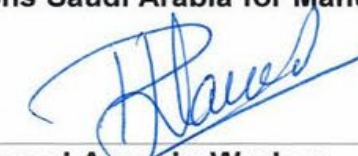

Prasad Anandu Warkar
Quality Manager

Date : 19th June 2022
Ref. No. : AA/PW/030/2022





PROJECT / PARCEL		Area 1 - CL J01- Parcel 504		PROGRAMME No.		KAFD 0112			
OCS NUMBER		KAFD-A1-504-SAB-COM-PQD-00001-R3		DATE		26-May-21			
ORIGINATOR		SAB		TRANSMITTAL No. / DATE		WF-000389 QAQC			
DOCUMENT No.		KAFD-A1-504-SAB-COM-PQD-00001-R3		DISCIPLINE		Structure			
DOCUMENT TITLE		OCS - J01-P504-PQD-Structural Strength work for columns (Retrofitting) and repair (Gulf Crete Ltd) KAFD-A1-504-SAB-COM-PQD-00001-R3		DOCUMENT TYPE		PQD			
Comments / Replies Legends & Status				Comment Code Legend (for individual comments): 1 = Action Required; 2 = Note / Advisory / Recommendation		Reply Code Legend: i = Incorporated; ii = Not incorporated for reason stated in reply		Open / Closed	
No.	Initial	Page / Section / Sheet	Comment Code	Reviewer Comment	Reply Code	Originator Reply	Reply Status by Reviewer		
1	MI	Gen	2	Years of Experience: 20 Years (Operating Experience in KSA)					
2	MI	Gen	2	JASARA PQD form is attached. Commercial registration certificate from Ministry of commerce attached and valid, ZAKAT & Tax Certificate attached and valid, GOSI certificate attached and valid.					
3	MI	Gen	2	Chamber of commerce (attached in hard copy)- valid, VAT Registration Certificate attached , Saudization Certificate attached and valid.					
4	MI	Gen	2	List of Previous Projects with documented evidences such as List of Partnerships & Valued Costumers, Major Projects & References are attached. Customers Approval and certificates from clients for completed works are included.					
5	MI	Gen	2	ISO Certificates provided , Quality Management System (QMS) is attached, HSE Policy & Manual is attached, Key Management and Company Organizational Chart attached, Technical Resources CVs are attached.					
6	MI	Gen	2	Contractor submitted Training certificates of applicators for CFRP jacketing works, Previous Project list accomplished for CFRP works attached, Attached Method statement of CFRP from supplier, Attached Test reports of CFRP, Attached Approvals from clients					
6	MI	Gen	2	Comments are made on the documents as presented. The content remains the responsibility of the author in all respects					
7	MI	Gen	1	Acceptance of the PQD is subjected to JLL approval					
Review Status Code:			B	A-Approved D - No Objection		B - Approved with Comments E - No Objection with Comments		C - Objection	
Reviewer Name(s) / Initials		Position	Supervision Consultant (SC)		Project Management-Construction Management (PMCM)		Programme Management Office (PMO)		Originator
Mohammed Imranuddin (MI)		Structural Engineer	COMMENTS / STATUS RECOMMENDED BY SC		COMMENTS / STATUS RECOMMENDED BY PMCM		COMMENTS / STATUS ADVISED BY PMO		REPLY APPROVED BY
Name:			Name: Paul Atkinson		Name:		Name:		Name:
Position:			Position: Project Director		Position:		Position:		Position:
Signature:			Signature:		Signature:		Signature:		Signature:
Date:			Date:		Date:		Date:		Date:









الرقم: ١٤ / ١
 التاريخ: ٢٠٢٠ / ٨ / ٣
 المجلس الفيدرالي للمقاولين العرب - الأمانة العامة
 الملكة العربية السعودية - ص.ب ٧١٥٣ الرياض ١١٤٦٢
 تلفون ٤٨٢٧٧٧٧ فاكس ٤٨٢٩٠٨٩

((شهادة إنجاز))

رقم التعميد	4700000078	التاريخ	2020/05/22م
المعهد	شركة خليج الغرسانة		
بشان	تنفيذ أعمال التدميم الانشائي لقرن سكن معالي الامين العام		
تاريخ الاستلام	2020/08/02م		
الملاحظات	لا يوجد		

مدير إدارة الخدمات العامة
 خالد عبدالله المبارك

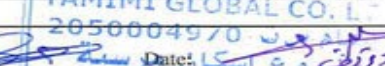
قسم المشاريع الهندسية والخدمات الفنية
 م/ بدر عبدالعزيز الهومي

							
Client : National Housing Company		PMC : Dar al-handasah		Consultant : Khatib & Alami		General Contractor : Tamimi Global Company Ltd.	
SUPPLIER PRE-QUALIFICATION							
AR	ME	CV	LA	Submittal No.	S	P	-
ST	EE	QS	OT	Date : 7/13/2020	1	2	4
To: Khatib & Alami				From: Tamimi Global Company Ltd.			
Supplier Description				Attachments			
Name: GULF CRETE LTD THE SPECIALIZED CO.				<input checked="" type="checkbox"/> Company Profile			
Telephone No.: 0114655034				<input checked="" type="checkbox"/> Valid Commercial Registration Certificate			
Address: RIYADH-KSA				<input checked="" type="checkbox"/> Valid Membership of Chamber of Commerce			
Person in Charge and His Mobile No: 599281826				<input checked="" type="checkbox"/> Valid VAT Registration Certificate			
Supplier's Qualifying Log:				<input checked="" type="checkbox"/> Valid Zakat & Tax Certificate			
Years of Experience (In Total): 20 YEARS				<input checked="" type="checkbox"/> Valid General Organization of Social Insurance			
Years of Experience In Saudi Arabia: 20 YEARS				<input checked="" type="checkbox"/> Valid Saudization Certificate			
				<input type="checkbox"/> Valid Contractor Classification Certificate			
				<input type="checkbox"/> Valid SASO Certificate			
				<input checked="" type="checkbox"/> Authorized Signatory of Responsible Person			
Material to Supply: WATERPROOFING, INSULATION, FIREPROOFING, CONCRETE REPAIRS, AND FLOOR COATINGS							
Approval of Supplier does not relieve contractor of his responsibilities under contract's terms.							
Contractor's Remarks: Hardcopy of company profil (3) , cd -softcopy (3)							
Contractor Incoming: Signature:  Date: 2020/08/04				Contractor Outgoing: Signature: _____ Date: _____			
Consultant Comments: MURCIA HOUSING PROJECT							
<p>SUPPLIER APPROVED TO PROVIDE THE ABOVE MENTIONED MATERIAL.</p> <p>MATERIAL TO BE PROVIDED AND AREA OF APPLICATION IS SUBJECT TO CONSULTANT APPROVAL.</p> <p>ANY MISSING CERTIFICATE, OR OUTDATED CERTIFICATE TO BE PROVIDED.</p>							
For K&A : Signature:  Date: 14/7/20							
ACTION CODE: A = Approved <input checked="" type="checkbox"/> B = Approved as noted <input checked="" type="checkbox"/> C = Resubmit as Noted <input type="checkbox"/> D = Disapproved <input type="checkbox"/>							
NOTE: The Client - National Housing Company (NHC) has the authority to approve/disapprove the supplier without any objection from _____ sides.							



TRANSMITTAL DETAILS

Program: 7 Construction Supervision
 Project: KAFD-A1-CJ01-GEN-CS-TRN-00814
 Transmittal ID: PQD-Prequalification No.00044-R1
 Subject: and 00052-R0 PGEN for Approval
 Purpose: For Approval
 Issue date: 9/5/2023
 Response due date: 9/20/2023

SENDER

Issued by: Ahmad, Ahlaq
 Email: a.hlaq.ahmad@daralriyadh.com
 Phone (1):
 Phone (2):

RECIPIENTS

Recipient name	Response required	Company	Recipient title	Email
Mohamed Farooq	NO	DAR-AL Riyadh	QA QC Engineer	Mohamed.Farooq@daralriyadh.com
Paul Atkinson	NO	DAR-AL Riyadh	Project Manager	Paul.Atkinson@daralriyadh.com
Abda Ikader Al-Bakour	YES	JLL	Project Manager	Abdalikader.Bakour@eu.jll.com
Ahmed Batoot	YES	JLL	Project Manager	Ahmed.Batoot@eu.jll.com
Brad Adams	NO	JLL	Construction Director	Brad.Adams@eu.jll.com
David Connolly	NO	JLL	Technical Director	David.Connolly@eu.jll.com
Desai Birju	NO	JLL	Sr. Planner	Birju.Desai@eu.jll.com
Fazal Reman	NO	JLL	Document Controller	Fazal.Reman@eu.jll.com
Greg Potts	NO	JLL		Greg.Potts@eu.jll.com
Ian Armstrong	YES	JLL	Project Director	Ian.Armstrong@eu.jll.com
JLL KAFD Document Control	NO	JLL	Document Control	JLL.MENAKAFDDocumentControls@eu.jll.com
Mervyn Nicholl	YES	JLL	Delivery Team	Mervyn.Nicholl@eu.jll.com
Ricardo Fachin	YES	JLL	Sr. Project Manager	Ricardo.Fachin@eu.jll.com
Wilus VanZyl	YES	JLL	Associate Director	Wilus.VanZyl@eu.jll.com
Ziad Sinno	YES	JLL	Project Manager	Ziad.Sinno@eu.jll.com

NOTES

All,
 Please find the attached PQD's No 00044-R1 and 00052-R0 for your information and approval as well.
 Regards,
 Ahlaq Ahmad

ATTACHMENT

Item no.	File name	Version	State	Description	Review Code
1	KAFD-RY-RIA1-PGEN-SAB-COM-PQD-00044-R1.pdf	R01	Published	PQD for Alkur Mamariyah Est to Cover Steel and Grating Works	
2	KAFD-RY-RIA1-PGEN-SAB-COM-PQD-00052.pdf	R00	Published	PQD for Epoxy Applicator (Gulf Crete Ltd)	B

REFERENCES

Item no.	File name	Version	State	Reference of
1				

GENERAL INFORMATION

Discipline		Document Type	Hard Copy Received	
PMT	MEP	LTR	Hard Copy	
PCM	ELE	DWG	Soft Copy (CD/DVD)	
DCM	CON	Tech Dec		
BSK	QMS	MOM	Hard Copy Received By:	
COM	HSE	RPT	Name:	RECEIVED BY
ENG	SHM	WPR	Title:	
ARC	ADM	MPR	Signature:	08 SEP 2023
Civil	HRM	Other		

FOR RECIPIENT/REVIEWER USE ONLY

Review Status	Approved-A	No Objection-D	Incomplete Document to Review
Approved with Comment-B	<input checked="" type="checkbox"/>	No Objection with Comment-E	Accepted for Construction
Objection C	<input type="checkbox"/>	No Review Required	Accepted As-Built

Reviewer Comment

Refer to OCS sheet

Reviewed By:	Approved By:
Name: Ziad Sinno	Name: [Signature]
Title: PM	Title: [Signature]
Signature: [Signature]	Signature: [Signature]



APPROVED APPLICATOR CERTIFICATE

GULF CRETE CO.

This is to advise that, M/S GULF CRETE CO. has been registered as an approved applicator and the company demonstrated competence in applying the following Master Builders Solutions Saudi Arabia product/s range below:

- » Epoxy & PU Flooring Systems
- » Waterproofing system
- » Concrete Repair

This certificate has been issued upon the request of GULF CRETE CO. without having any liability on Master Builders Solutions Saudi Arabia. It is the sole responsibility of GULF CRETE CO. to strictly follow the written Method Statement, use proper tools/equipment and maintain good workmanship while applying the products.

This certificate is valid for **6 months** from this date and Master Builders Solutions Saudi Arabia reserve the right to cancel / withdraw the certificate any time if the application of the products is not in line with our written Method Statement. In the occurrence of the above, this certificate become null and void.

For and on behalf of
Master Builders Solutions Saudi Arabia for Manufacturing LLC

Date : 2nd April 2023
 Ref. No. : AA/PW/075/2023

Prasad Anandu Warkar
 Quality Manager

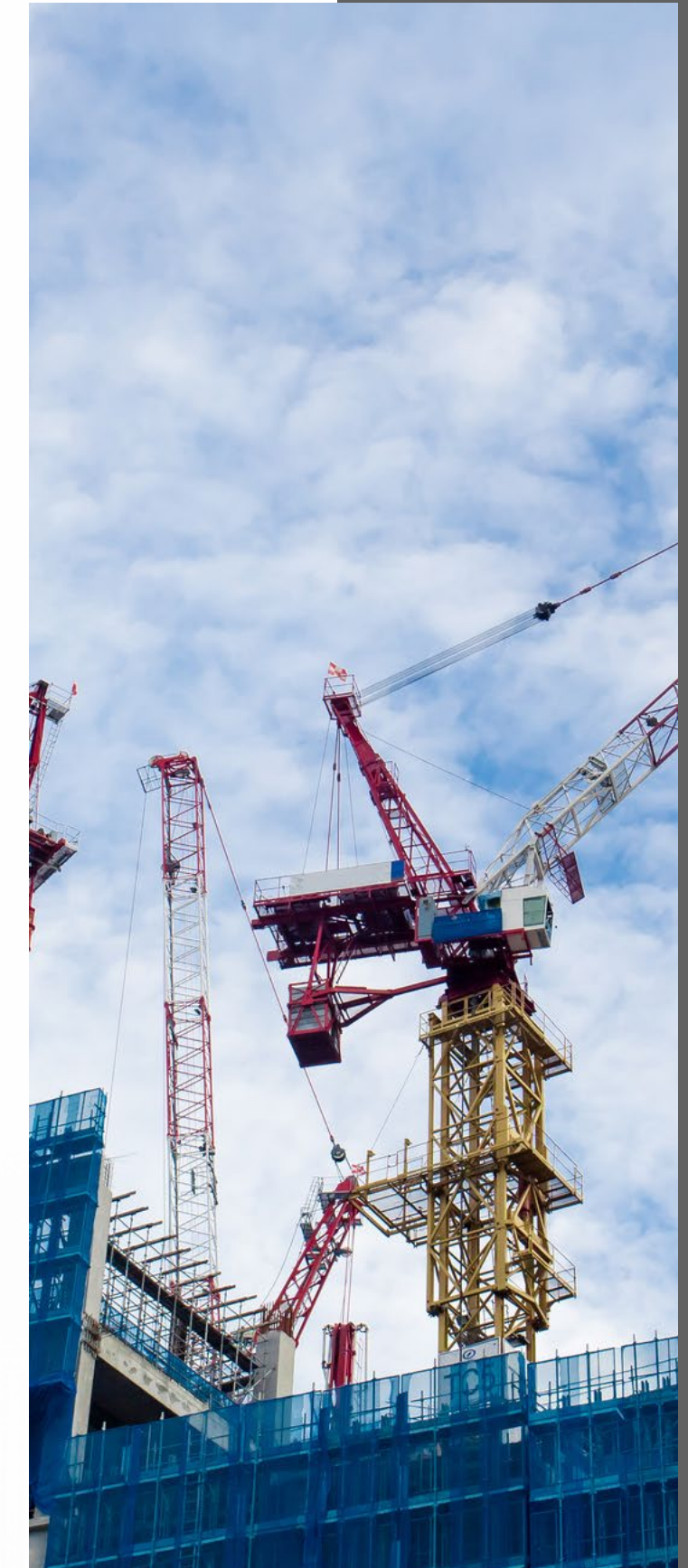



Ref : AY/06/22

Date: June 21, 2022.

TO WHOM IT MAY CONCERN

This is to certify that M/s. **Gulferete** have considered as our certified and approved applicator for following Fosam Products' Range as below:

- Concrete Repair.
- Protective Coatings.
- Industrial Flooring.
- Joint Sealants.

This certificate is issued upon their request without any liabilities on Fosam Company Limited and valid for six months from the date of issuance of this certificate.

Yours sincerely,
For Fosam Company Limited



Fosam Company Limited
Head Office
PO Box 11061
Jeddah - 21453
Saudi Arabia
C.R. No. 31273
Paid up Capital: SR3,000,000
www.fosroc.com

Phone: +966 (0) 537 5325 Fax: +966 (0) 537 5327
Email: team@fosroc.com



Client : National Housing Company		PMC : Dar al-handasah		Consultant : Khatib & Alami		General Contractor : Tamimi Global Company Ltd.	
SUPPLIER PRE-QUALIFICATION							
AR	ME	CV	LA	Submittal No.	S	P	- 1 2 4 Rev. 0 0
ST	EE	QS	OT	Date: 7/13/2020	Contract Drawing No.		
To: Khatib & Alami				From: Tamimi Global Company Ltd.			
Supplier Description				Attachments			
Name: GULF CRETE LTD THE SPECIALIZED CO.				<input checked="" type="checkbox"/> Company Profile			
Telephone No.: 0114655034				<input checked="" type="checkbox"/> Valid Commercial Registration Certificate			
Address: RIYADH-KSA				<input checked="" type="checkbox"/> Valid Membership of Chamber of Commerce			
Person in Charge and His Mobile No: 599281826				<input checked="" type="checkbox"/> Valid VAT Registration Certificate			
Supplier's Qualifying Log:				<input checked="" type="checkbox"/> Valid Zakat & Tax Certificate			
Years of Experience (In Total): 20 YEARS				<input checked="" type="checkbox"/> Valid General Organization of Social Insurance			
Years of Experience In Saudi Arabia: 20 YEARS				<input checked="" type="checkbox"/> Valid Saudization Certificate			
				<input type="checkbox"/> Valid Contractor Classification Certificate			
				<input type="checkbox"/> Valid SASO Certificate			
				<input checked="" type="checkbox"/> Authorized Signatory of Responsible Person			
Material to Supply: WATERPROOFING, INSULATION, FIREPROOFING, CONCRETE REPAIRS, AND FLOOR COATINGS							
Approval of Supplier does not relieve contractor of his responsibilities under contract's terms.							
Contractor's Remarks: Hardcopy of company profil (3) , cd -softcopy (3) TAMIMI GLOBAL CO. L.							
Contractor Incoming: Signature: Date: 14/7/20				Contractor Outgoing: Signature: _____ Date: _____			
Consultant Comments: MURCIA HOUSING PROJECT							
<p>• SUPPLIER APPROVED TO PROVIDE THE ABOVE MENTIONED MATERIAL.</p> <p>• MATERIAL TO BE PROVIDED AND AREA OF APPLICATION IS SUBJECT TO CONSULTANT APPROVAL.</p> <p>• ANY MISSING CERTIFICATE, OR OUTDATED CERTIFICATE TO BE PROVIDED</p>							
For K&A : Signature: Date: 14/7/20							
ACTION CODE: A = Approved <input type="checkbox"/> C = Resubmit as Noted <input type="checkbox"/> B = Approved as noted <input checked="" type="checkbox"/> D = Disapproved <input type="checkbox"/>							
NOTE: The Client - National Housing Company (NHC) has the authority to approve/disapprove the supplier without any objection from all sides.							





شركة بي إي إس إف السعودية - غواد البناء المحدودة
 برج العثمان الطابق رقم 14
 طريق الملك سعود، الشقة 31142 - الظهران 31142
 ص. ب. الخبر 31142 - المملكة العربية السعودية
Saudi BASF For Building Materials Co. Ltd.
 Al-Othman Business Tower 14th Floor
 King Saud Road, Al Qashlah, Dhahran 34232
 P.O. Box 1884, Al Khobar 31952

26th February 2017
 Ref:/JT/L001/26022017

PRE – QUALIFICATION CERTIFICATE OF CONFIRMITY

This is to acknowledge that **M/S Gulf Crete Ltd. Contracting Company.** Has submitted company profile and other relevant documents to **SAUDI BASF, For Building Materials Co Ltd** for authorized applicator approval purpose. Hereby we are certifying that they are under review and authorized to apply our products as below.

- WATERPROOFING SYSTEMS
- Epoxy and PU flooring system
- Concrete Repair

Further to their team of supervisor had maintained good quality work. Hence, they are prequalified applicators to the Saudi BASF range of products as described above.

The pre-qualification is valid for one year from this date and subject to remain under constant monitoring for using **Saudi BASF – The Chemical Company** products. This pre-qualification can be withdrawn, if the quality of application is not to BASF's satisfaction.

For and on Behalf of
Saudi BASF Co.Ltd.

(Signature)

Jignesh Thakkar.
 Technical Manager



Head Office: المكتب الرئيسي:
 Tel : +966 13 853 8600, 13 812 1140 فاكس: +٩٦٦ ١٣ ٨٥٣ ٨٦٠٠/١٣ ٨١٢ ١١٤٠
 Fax: +966 13 832 8671, 13 812 1822 فاكس: +٩٦٦ ١٣ ٨٣٢ ٨٦٧٧/١٣ ٨١٢ ١٨٢٢
 www.master-builders-solutions.sa
 enquiry@saudi@basf.com



شركة ذات مسئولية محدودة في المملكة العربية السعودية رأس المال المدفوع 11 مليون ريال سجل تجاري رقم ٢٠٠٠٢٧٢٠
 المكتب المسجل، طريق رقم ٥٨ المنطقة الصناعية الثالثة، الدمام، المملكة العربية السعودية هاتف: +٩٦٦ ١٣ ٨١٢ ١٢٢١ فاكس: +٩٦٦ ١٣ ٨١٢ ٢٣٦٦
 A private Company Incorporated with limited liability in the KSA, Paid Up Share Capital SR 11 Million, Commercial Registration No. 2050037620
 Registered Office, Street No 58, Dammam 2nd Industrial Area, Saudi Arabia, Tel : +966 13 812 1231. Fax : +966 13 812 3269



CERTIFICATION

CERTIFICATE

FOR RECOMMENDED SIKA APPLICATORS

This is to certify that

GULF CRETE CONTRACTING

Has successfully executed many Projects after having passed the application training of various Sika systems and is Recommended Sika Applicator for

Concrete repair and protection, Waterproofing (PVC membranes loose laid and full comparmet system), Cementitious, Resins, Combiflex range), Joint Sealants and Industrial flooring.

This comprehensive training consisted of practical instructions about proper storage, preparation and application of Sika products.

The recommended applicator has been provided with the relevant Sika Product Data Sheets and all other technical documentation.

This confirmation is valid until the date of expiry below and may be renewed subject to the Recommended Applicator successfully completing any training courses required by Sika. The Recommended Applicator is responsible for ensuring full compliance by its employees with Sika's guidelines, training instructions and any other requirements of third parties.

Sika is not responsible for any loss or damage suffered by any third party as a result of any acts or omissions of the Recommended Applicator arising in anyway, including but not limited to breach of contract, misrepresentation, failure to comply with applicable laws or any other tort including negligence.

Sika Saudi Arabia,

Issuing Date: January 01, 2016

Expiry Date: December 31, 2016

(Signature)

Shehadeh Salman
 T.M Waterproofing Manager
 Central Region
 Sika Saudi Arabia



(Signature)

Emad Al Asqar
 Sr. Sales Manager
 Central Region
 Sika Saudi Arabia

This Recommendation does not assume responsibility for the correct storage, mixing or use of these Products. Sika shall not be liable for damage to persons or property, loss of business or profit or any other direct, indirect, incidental, special or consequential damage so caused by the Recommended Applicator. Sika shall also not be responsible for use of these Products in a manner to infringe on any patent or other intellectual property rights held by others. Sika's liability is limited to the quality only of the supplied material. Any failures due to wrong application or storage not in accordance with the given guidelines as stated on the label, Technical Data sheet, as well as structural or mechanical failures are excluded herein.



CERTIFICATION

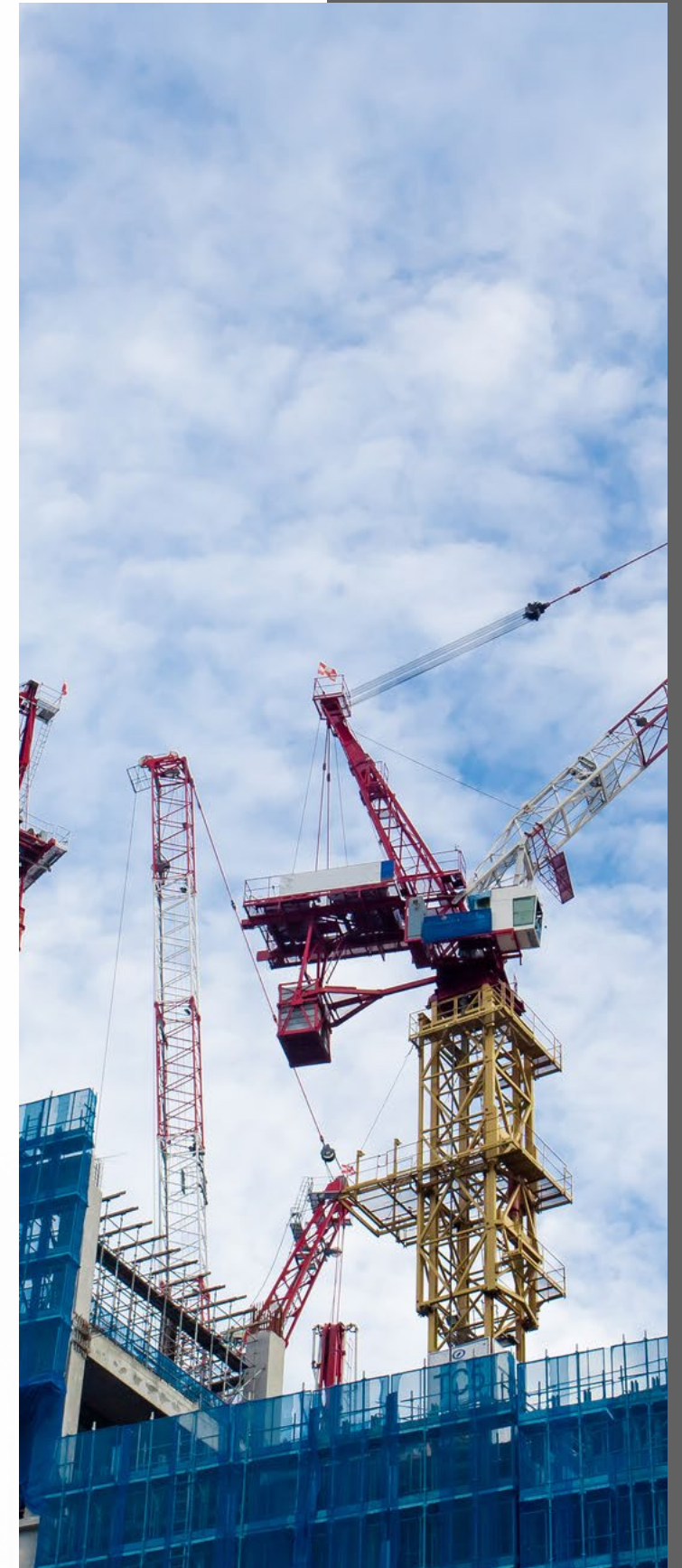

شركة دي سي بي السعودية

DCP Saudi

Date: 22nd November 2014

TO WHOM IT MAY CONCERN

This is to certify that **M/s Gulf Crete Ltd.** is our approved and certified applicator for all **DCP Saudi Company** Products for following ranges:

- Waterproofing system
- Joint Sealant
- Protective coating for concrete and masonry
- Epoxy Flooring
- Concrete repair
- Injection

This certificate is issued upon their request and without any liabilities on **DCP Saudi Company**, and valid for Six months from the date of issuance of this certificate.

Yours Sincerely,



For
DCP Saudi Co.

DCP Saudi
PO Box 6241 Riyadh 11576
Kingdom of Saudi Arabia
Tel. + 966 11 461 2003
Fax + 966 11 279 2059
Info.saudi@dcp-saudi.com
www.dcp-saudi.com

experience quality full range

رأس المال المملووع ١٠٠٠٠٠٠٠ ريال سعودي، ص.ن. ١٠١٠٢١٧١٢٠ رقم العضوية ٢١٧٠٧١ Licence: 217074 Capital Paid: 1000000 S.R CR. # 1010267930



CERTIFICATE

FOR RECOMMENDED SIKA APPLICATORS

This is to certify that

GULF CRETE CONTRACTING

Has successfully executed many Projects after having passed the application training of various Sika systems and is Recommended Sika Applicator for

Concrete repair and protection, Waterproofing (PVC membranes loose laid and full compartment system), Cementitious, Resins, Combiflex range), Joint Sealants and Industrial flooring.

This comprehensive training consisted of practical instructions about proper storage, preparation and application of Sika products.

The recommended applicator has been provided with the relevant Sika Product Data Sheets and all other technical documentation.

This confirmation is valid until the date of expiry below and may be renewed subject to the Recommended Applicator successfully completing any training courses required by Sika. The Recommended Applicator is responsible for ensuring full compliance by its employees with Sika's guidelines, training instructions and any other requirements of third parties.

Sika is not responsible for any loss or damage suffered by any third party as a result of any acts or omissions of the Recommended Applicator arising in anyway, including but not limited to breach of contract, misrepresentation, failure to comply with applicable laws or any other tort including negligence.

Sika Saudi Arabia,

Issuing Date: January 01, 2016 Expiry Date: December 31, 2016

Shehadeh Salman
 T.M Waterproofing Manager
 Central Region
 Sika Saudi Arabia

Emad Al Asqar
 Sr. Sales Manager
 Central Region
 Sika Saudi Arabia

This Recommendation does not assume responsibility for the correct storage, mixing or use of these Products. Sika shall not be liable for damage to persons or property, loss of business or profit or any other direct, indirect, incidental, special or consequential damage so caused by the Recommended Applicator. Sika shall also not be responsible for use of these Products in a manner to infringe on any patent or other intellectual property rights held by others. Sika's liability is limited to the quality only of the supplied material. Any failures due to wrong application or storage not in accordance with the given guidelines as stated on the latest Technical Data Sheets, as well as structural or mechanical failures are excluded herein.

BUILDING TRUST 



BASF
The Chemical Company

Saudi BASF For Building Materials Co. Ltd. PO Box 1884 Al-Khobar 31922 KSA
شركة أم بي بي اسفودج
For Building Materials Co. Ltd.
جودة البناء المحدودة
P.O. Box 1884
الخبور 31952
المملكة العربية السعودية
Kingdom of Saudi Arabia

18th OCTOBER 2015
Ref. RUH/AI/0050-15

M/s. GULF CRETE

PRE – QUALIFICATION CERTIFICATE OF CONFORMITY

This is to certify that M/s GULF CRETE had worked with Saudi BASF range of products with the following product groups:

- Epoxy & PU Flooring systems
- Waterproofing systems
- Concrete repair

Their Team of supervisor had so far demonstrated good quality work in application and workmanship. Hence, they are granted as pre-qualified applicator for the Saudi BASF range of products as described above.

This pre-qualification is valid for one year from this date and subject to remain under constant monitoring for using Saudi BASF - The Chemical Company products. This pre-qualification can be withdrawn during the duration of this period, if the quality of application is not to BASF's Standards and Guidelines.

For and on behalf of
Saudi BASF Co. Ltd.

Technical Manager



Head Office
Tel: +966 3 8121140
Fax: +966 3 8121822
www.mot-saudi-arabia.com
inquiry@saudi@basf.com

A Private Company incorporated with limited liability in the Kingdom of Saudi Arabia
Paid up Share Capital SR. 8.5 Million
Commercial Registration No. 2050027820
COC Membership No. 476







FOSROC
constructive solutions

Ref : KR/0513/05
Date : 22nd November 2014

TO WHOM IT MAY CONCERN

This is to certify that **M/s. Gulf Crete LTD.** is our approved and certified applicators for all Fosam Products for the following range of applications:

- Joint sealing works.
- Specialized protective coating for concrete and masonry.
- Epoxy Flooring
- Concrete Repair

This certificate is issued upon their request and without any liabilities on Fosam Company Limited and valid for three months from the date of issuance of this certificate.

Yours sincerely,
For **Fosam Company Limited**

Kareem Rabayah
Area Sales Manager-Central Region
Mobile: 0553829272

شركة فوسام المحدودة
Fosam Company Limited
مبنى 153 - طريق تكاسوس - الرياض 11523
C.R. No. 31273
Tel: 482 9303 8124242

Fosam Company Limited
Riyadh Office
P.O. Box 50391
Riyadh - 11523
C.R. No. 31273
Paid up Capital: SR 3,000,000
www.fosroc.com

Registered Office: Building No. 153, Takasos' Road, North Makkah

telephone: 00 966 1 482 9303 fax: 00 966 1 482 7562 e-mail: fosam_riyadh@fosroc.com

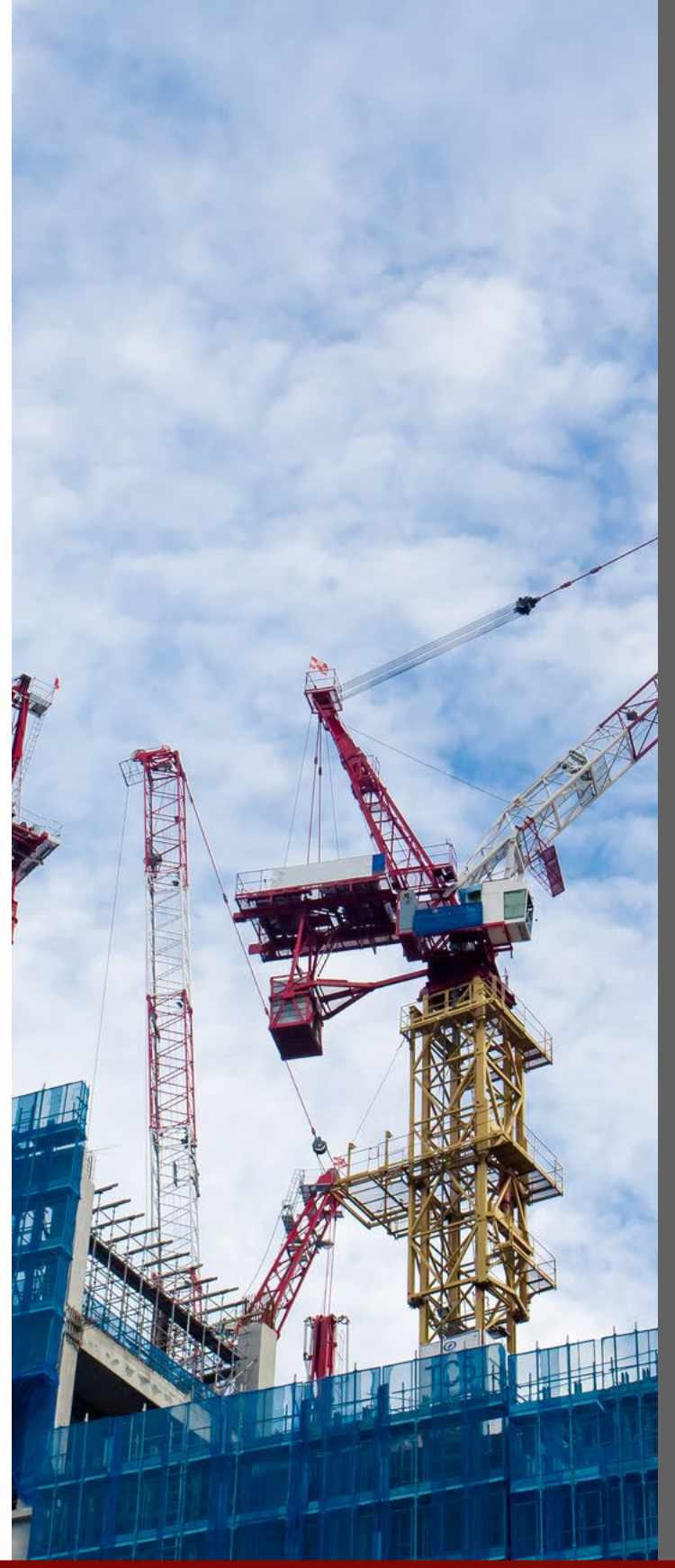

A1 -Parcel 5.04 Mixed Use (Office + Retail + Residential)
 King Abdullah Financial District
 King Fahd Rd 11564
 Central Region 13519
 Riyadh
 Riyadh Saudi Arabia



MAIL TYPE: Workflow Transmittal
 MAIL NUMBER: DAR-WTRAN-001464
 REFERENCE NUMBER: DAR-WTRAN-001464

Final (WF-000387) DAR WF (Baytur) - J01-P504-PQD-Structural Strength work for columns (Retrofitting) and repair (Gulf Crete Ltd) REV-03

From: Mr Paul Atkinson - Dar Al Riyadh Engineering & Architecture
 To (2): Mr Paul Atkinson - Dar Al Riyadh Engineering & Architecture (+1 more...)
 Cc (3): Mr fazal rehman - Jones Lang Lasalle (+2 more...)
 Sent: Wednesday, 26 May 2021 3:07:05 PM AST (GMT +03:00)
 Status: N/A



DOCUMENT ATTACHMENTS (1)

File	Document No	Revision	Revision Date	Title	Status
	KAFD-A1-504-SAB-COM-PQD-00001	03	24/05/2021	J01-P504-PQD-Structural Strength work for columns (Retrofitting) and repair (Gulf Crete Ltd)	B - Approved with Comments

ATTRIBUTES

Attribute 1: ARC - Architect, ELE - Electrical, MEC - Mechanical, MEP - Mechanical & Electrical & Plumbing, SST - Steel Structure, STL - Structural

MESSAGE

Workflow Review History

The attached documents have completed the "DAR WF (Baytur) - J01-P504-PQD-Structural Strength work for columns (Retrofitting) and repair (Gulf Crete Ltd) REV-03" workflow with the following results :

This transmittal was automatically generated.

Doc No	Step	Participant	Review Outcome	Comments
KAFD-A1-504-SAB-COM-PQD-00001	PD	P Atkinson	B - Approved with Comments	No Objection, PQD only, no materials approved.

CERTIFICATION

Consultant 	Client 	Contractor 	
PROJECT NO: KSUEH-BUILDING 04		LOCATION: RIYADH-KSA	
MATERIALS SUBMITTAL			
SUBMITTAL NO: KSUEH-45-AR-0010		PREV. SUBMITTAL NO:	
DATE: 19 Feb-17		PREV. SUB AL DATE:	
Submittal reason: <input type="checkbox"/> INFO <input type="checkbox"/> NOTES <input checked="" type="checkbox"/> APPROVAL			
Major: <input type="checkbox"/> CV <input checked="" type="checkbox"/> AR <input type="checkbox"/> ST <input type="checkbox"/> AC <input type="checkbox"/> EL <input type="checkbox"/> PL <input type="checkbox"/> OTHER			
Attachments: <input checked="" type="checkbox"/> Brochure <input checked="" type="checkbox"/> Tech. Info <input type="checkbox"/> Sample <input checked="" type="checkbox"/> Certificate <input type="checkbox"/> Drawing <input type="checkbox"/> Calculations			
Materials/Tools			
Serial	Material Name, Number & Description	Source	Supplier / Manufacturer
1	Concrete Repairs	Local	Gulf Crete LTD.
2	Protective Coating (Epoxy)		
3	Fire Proofing		
4	Water Proofing		
CONTRACTOR			
Procurement Manager		Project Manager	
Name:		Name: Ayman Shaban	
Signature:		Site Engr. Muhamed Zyadeh	
Signature:		Signature:	
CONSULTANT NOTES			
*Accepted as a subcontractor and to be provide complete information and materials details and data sheet for review and approval.			
#provide warranty certificate as per project specs and contract.			
CONSULTANT		STRATEGIC CONSTRUCTION PROGRAM	
Name: Avazag Najjar		Date:	
Position: Arch		Signature:	
Signature:		Signature:	
Date: 24/2/2017		Date:	
Date:		Date:	
APPROVAL SITUATION			
<input checked="" type="checkbox"/> APPROVED		<input type="checkbox"/> REJECTED	
<input type="checkbox"/> APP. WITH COMMENTS		<input type="checkbox"/> NO ACTION	
<input type="checkbox"/> APP. AS NOTED/RESUBMITTAL REQUIRED			
INCOMING SIGNATURE: DATE:		OUTGOING SIGNATURE: DATE:	
DATE:		DATE:	
Consultant: Original Contractor: Copy with Stamp Consultant Site Office: Copy (Authority to proceed with work does not relieve the contractor from contractual responsibilities)			



A1 -Parcel 5.04 Mixed Use (Office + Retail + Residential)
 King Abdullah Financial District
 King Fahd Rd 11564
 Central Region 13519
 Riyadh
 Riyadh Saudi Arabia



MAIL TYPE: Workflow Transmittal
 MAIL NUMBER: DAR-WTRAN-001464
 REFERENCE NUMBER: DAR-WTRAN-001464

Final (WF-000387) DAR WF (Baytur) - J01-P504-PQD-Structural Strength work for columns (Retrofitting) and repair (Gulf Crete Ltd) REV-03

From: Mr Paul Atkinson - Dar Al Riyadh Engineering & Architecture
 To (2): Mr Paul Atkinson - Dar Al Riyadh Engineering & Architecture (+1 more...)
 Cc (3): Mr fazal rehman - Jones Lang Lasalle (+2 more...)
 Sent: Wednesday, 26 May 2021 3:07:05 PM AST (GMT +03:00)
 Status: N/A



DOCUMENT ATTACHMENTS (1)

File	Document No	Revision	Revision Date	Title	Status
	KAFD-A1-504-SAB-COM-PQD-00001	03	24/05/2021	J01-P504-PQD-Structural Strength work for columns (Retrofitting) and repair (Gulf Crete Ltd)	B - Approved with Comments

ATTRIBUTES

Attribute 1: ARC - Architect, ELE - Electrical, MEC - Mechanical, MEP - Mechanical & Electrical & Plumbing, SST - Steel Structure, STL - Structural

MESSAGE

Workflow Review History

The attached documents have completed the "DAR WF (Baytur) - J01-P504-PQD-Structural Strength work for columns (Retrofitting) and repair (Gulf Crete Ltd) REV-03" workflow with the following results:

This transmittal was automatically generated.

Doc No	Step	Participant	Review Outcome	Comments
KAFD-A1-504-SAB-COM-PQD-00001	PD	P Atkinson	B - Approved with Comments	No Objection, PQD only, no materials approved.

SUBCONTRACTOR PREQUALIFICATION SUBMITTAL FORM

Submittal Ref.	KSP-FHJ-INW-CMT-CIV-PQD-0140	Revision	01	Date	14-Marc-2022
Program	King Salman Park				
Project	CP03 Infrastructure Works Phase 1 & O&M Center	Project No.	CP03		
Client	King Salman Park Foundation (KSPF)				
PMO	Saudi Arabian Parsons Ltd. (SAPL)	Contractor	Freyssinet-Haif JV (FHJ)		
PMC	Faithful Gould (FGS)	PMCM			

Discipline: Civil Architecture Mechanical Electrical Information Technology
 Landscape Others: C

Sub-Contractor / Supplier Details	Attachments	P / x
Name: GULF CERTE – Riyadh (APPLICATOR)	Chamber of Commerce Membership.	Y
Trade: All type of Water Proofing & Thermal Insulation (APPLICATOR)	Municipality License	Y
Location: Riyadh KSA	Other Licenses (Specify):	Y
Experience (Total No. of Years): 30 Years	Please refer to PQD documents.	
Experience in KSA: 30 Years		
Contact Name: GULF CERTE Head Office Riyadh Mobile Number: 966 599281826 (Shah Rukh Ali Hassan)		
Is the company certified against any quality standard? Yes	Pre-Qualification Doc's (Specify):	Y
Is the company certified against any Health & Safety and Environment standard? Yes	Please refer to PQD documents.	
Subcontractors / Supplier's Proposed Scope of Work in this project		
- Waterproofing & Damp proofing – EPDM – TPO- FPO – POLYUREA - Spray Polyurethane foam Waterproofing - Geosynthetic Engineering - Concrete Repair and Protection – injection work - Building Renovations - Expansion joint – fire proof – decorative and protective epoxy coating - Stamped Concrete - Light Weight Foam Concrete		
	Completion Certificates for Previous Projects	Y

Contractor Signatures & Stamp

Discipline Engineer	QA/ QC	HSE	MEP	Construction Manager

Submittal Status:
 A - Approved B - Approved as Noted C - Revise and Resubmit D - Rejected

Engineer's Comments: Complied our previous comments, contractor to keep all the documentation updated.

PMO/Client' Comments:

Name	Signature	Date



TRANSMITTAL DETAILS
 Program: 7 Construction Supervision
 Project: KAFD-A1-CJ01-GEN-CS-TRN-00814
 Transmittal ID: PQD-Prequalification No.00044-R1
 Subject: and 00052-R0 PGEN for Approval
 Purpose: For Approval
 Issue date: 9/5/2023
 Response due date: 9/20/2023

SENDER
 Issued by: Ahmad, Ahlaq
 Email: a.hlaq.ahmad@daralriyadh.com
 Phone (1):
 Phone (2):

Recipient name	Response required	Company	Recipient title	Email
Mohamed Farooq	NO	DAR-AL Riyadh	QA QC Engineer	Mohamed.Farooq@daralriyadh.com
Paul Atkinson	NO	DAR-AL Riyadh	Project Manager	Paul.Atkinson@daralriyadh.com
Abda Ikader Al-Bakour	YES	JLL	Project Manager	Abdalkader.Bakour@eu.jll.com
Ahmed Batoot	YES	JLL	Project Manager	Ahmed.Batoot@eu.jll.com
Brad Adams	NO	JLL	Construction Director	Brad.Adams@eu.jll.com
David Connolly	NO	JLL	Technical Director	David.Connolly@eu.jll.com
Desai Birju	NO	JLL	Sr. Planner	Birju.Desai@eu.jll.com
Fazal Reman	NO	JLL	Document Controller	Fazal.Rehman@eu.jll.com
Greg Potts	NO	JLL		Greg.Potts@eu.jll.com
Ian Armstrong	YES	JLL	Project Director	Ian.Armstrong@eu.jll.com
JLL KAFD Document Control	NO	JLL	Document Control	JLL.MENAKAFDDocumentControls@eu.jll.com
Mervyn Nicholl	YES	JLL	Delivery Team	Mervyn.Nicholl@eu.jll.com
Ricardo Fachin	YES	JLL	Sr. Project Manager	Ricardo.Fachin@eu.jll.com
Wilus VanZyl	YES	JLL	Associate Director	Wilus.VanZyl@eu.jll.com
Ziad Sinno	YES	JLL	Project Manager	Ziad.Sinno@eu.jll.com

NOTES
 All
 Please find the attached PQD's No 00044-R1 and 00052-R0 for your information and Approval as well.
 Regards,
 Ahlaq Ahmad

Item no.	File name	Version	State	Description	Review Code
1	KAFD-RY-RIA1-PGEN-SAB-COM-PQD-00044-R1.pdf	R01	Published	PQD for Alkur Mamariyah Est to Cover Steel and Grating Works	
2	KAFD-RY-RIA1-PGEN-SAB-COM-PQD-00052.pdf	R00	Published	PQD for Epoxy Applicator (Gulf Crete Ltd)	B

Item no.	File name	Version	State	Reference of
1				

GENERAL INFORMATION			Hard Copy Received	
Discipline	Discipline	Document Type	Hard Copy	
PMT	MEP	LTR	Soft Copy (CD/DVD)	
PCM	ELE	DWG		
DCM	CON	Tech.Dec		
BSK	QMS	MOM		
COM	HSE	RPT		
ENG	SHM	WPR		
ARC	ADM	MPR		
Civil	HRM	Other		

Hard Copy Received By:
RECEIVED BY
 Name: *[Signature]*
 Title: *[Signature]*
 Signature: *[Signature]*
 08 SEP 2023
 KAFD PROJECT

FOR RECIPIENT/REVIEWER USE ONLY

Review Status	Approved-A	No Objection-D	Incomplete Document to Review
Approved with Comment-B	No Objection with Comment-E	Accepted for Construction	
Objection C	No Review Required	Accepted As-Built	

Reviewer Comment
Refer to OCS sheet

Reviewed By: *Ziad Sinno*
 Name: *Ziad Sinno*
 Title: *PM*
 Signature: *[Signature]*

Approved By: *[Signature]*
 Name:
 Title:
 Signature: *[Signature]*



APPROVED APPLICATOR CERTIFICATE

GULF CRETE CO.

This is to advise that, M/S GULF CRETE CO. has been registered as an approved applicator and the company demonstrated competence in applying the following Master Builders Solutions Saudi Arabia product/s range below:

- » Epoxy & PU Flooring Systems
- » Waterproofing system
- » Concrete Repair

This certificate has been issued upon the request of GULF CRETE CO. without having any liability on Master Builders Solutions Saudi Arabia. It is the sole responsibility of GULF CRETE CO. to strictly follow the written Method Statement, use proper tools/equipment and maintain good workmanship while applying the products.

This certificate is valid for **6 months** from this date and Master Builders Solutions Saudi Arabia reserve the right to cancel / withdraw the certificate any time if the application of the products is not in line with our written Method Statement. In the occurrence of the above, this certificate become null and void.

For and on behalf of
Master Builders Solutions Saudi Arabia for Manufacturing LLC

Date : 2nd April 2023
 Ref. No. : AA/PW/075/2023

Prasad Anandu Warkar
 Quality Manager

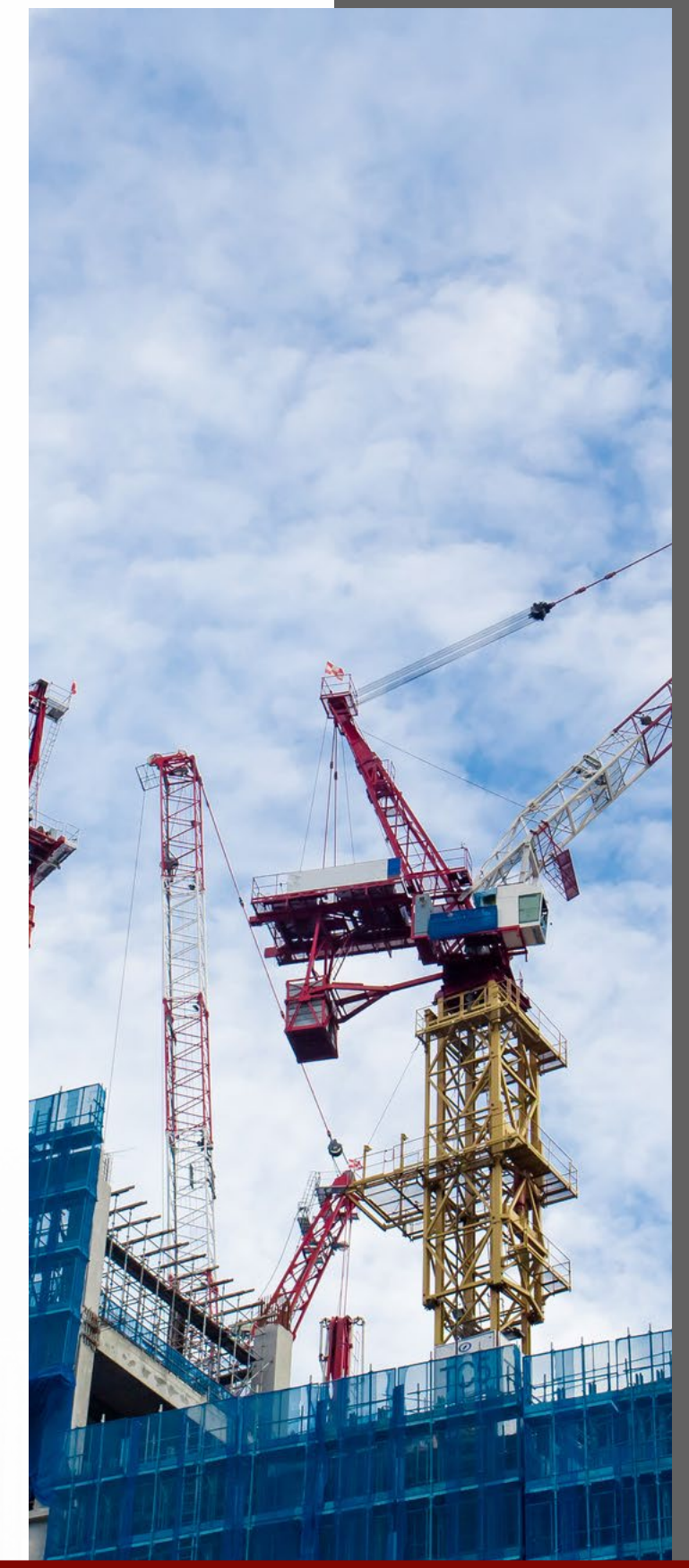

APPROVED APPLICATOR CERTIFICATE

GULF CRETE CO.

This is to advise that, **M/S GULF CRETE CO.** has been registered as an approved applicator and the company demonstrated competence in applying the following Master Builders Solutions Saudi Arabia product/s range below:

- » Epoxy & PU Flooring Systems
- » Waterproofing system
- » Concrete Repair

This certificate has been issued upon the request of **GULF CRETE CO.** without having any liability on Master Builders Solutions Saudi Arabia. It is the sole responsibility of **GULF CRETE CO.** to strictly follow the written Method Statement, use proper tools/equipment and maintain good workmanship while applying the products.

This certificate is valid for **6 months** from this date and Master Builders Solutions Saudi Arabia reserve the right to cancel / withdraw the certificate any time if the application of the products is not in line with our written Method Statement. In the occurrence of the above, this certificate become null and void.

For and on behalf of
Master Builders Solutions Saudi Arabia for Manufacturing LLC



Prasad Anandu Warkar
Quality Manager

Date : 19th June 2022
Ref. No. : AA/PW/030/2022





CERTIFICATION



شركة دي سي بي السعودية

Date: 22nd November 2014

TO WHOM IT MAY CONCERN

This is to certify that **M/s Gulf Crete Ltd.** is our approved and certified applicator for all **DCP Saudi Company** Products for following ranges:

- Waterproofing system
- Joint Sealant
- Protective coating for concrete and masonry
- Epoxy Flooring
- Concrete repair
- Injection

This certificate is issued upon their request and without any liabilities on **DCP Saudi Company**, and valid for Six months from the date of issuance of this certificate.

Yours Sincerely,



For
DCP Saudi Co.

DCP Saudi
PO Box 60241 Riyadh 11576
Kingdom of Saudi Arabia
Tel : + 966 11 461 2003
Fax : + 966 11 279 2059
Info.saudi@dcp-int.com
www.dcp-int.com



Capital Paid: 1000000 S.R CR. # 1010267930 Licence: 217074 رقم الترخيص: ٢١٧٠٧٤ ص.ب. ١٠١٠٢٦٧٩٣٠ الرياض ١١٥٧٦ رأس المال المدفوع: ١٠٠٠٠٠٠ ريال سعودي



CERTIFICATION

CERTIFICATE

FOR RECOMMENDED SIKA APPLICATORS

This is to certify that

GULF CRETE CONTRACTING

Has successfully executed many Projects after having passed the application training of various Sika systems and is Recommended Sika Applicator for

Concrete repair and protection, Waterproofing (PVC membranes loose laid and full compartment system), Cementitious, Resins, Combiflex range), Joint Sealants and Industrial flooring.

This comprehensive training consisted of practical instructions about proper storage, preparation and application of Sika products.

The recommended applicator has been provided with the relevant Sika Product Data Sheets and all other technical documentation.

This confirmation is valid until the date of expiry below and may be renewed subject to the Recommended Applicator successfully completing any training courses required by Sika. The Recommended Applicator is responsible for ensuring full compliance by its employees with Sika's guidelines, training instructions and any other requirements of third parties.

Sika is not responsible for any loss or damage suffered by any third party as a result of any acts or omissions of the Recommended Applicator arising in anyway, including but not limited to breach of contract, misrepresentation, failure to comply with applicable laws or any other tort including negligence.

Sika Saudi Arabia,

Issuing Date: January 01, 2016

Expiry Date: December 31, 2016



Shehadeh Salman
T.M Waterproofing Manager
Central Region
Sika Saudi Arabia





Emad Al Asqar
Sr. Sales Manager
Central Region
Sika Saudi Arabia

This Recommendation does not assume responsibility for the correct storage, mixing or use of these Products. Sika shall not be liable for damage to persons or property, loss of business or profit or any other direct, indirect, incidental, special or consequential damage so caused by the Recommended Applicator. Sika shall also not be responsible for use of these Products in a manner not in accordance with the given guidelines as stated on the latest Technical Data Sheet, as well as structural or mechanical failures are excluded herein.

BUILDING TRUST







CERTIFICATION

BASF
The Chemical Company

Saudi BASF For Building Materials Co.Ltd. PO Box1884 Al-Khobar 31952.KSA

18th OCTOBER 2015
Ref. RUH/AI/0050-15

M/s. GULF CRETE

Saudi BASF
شركة المواد الإنشائية
For Building Materials Co.Ltd.
P.O.Box 1884
Al-Khobar 31952
Kingdom of Saudi Arabia

Head Office
Tel: +966 3 8121140
Fax: +966 3 8121822
www.mot-saudi-arabia.com
inquiryco.saudi@basf.com

PRE – QUALIFICATION CERTIFICATE OF CONFORMITY

This is to certify that M/s GULF CRETE had worked with Saudi BASF range of products with the following product groups:

- Epoxy & PU Flooring systems
- Waterproofing systems
- Concrete repair

Their Team of supervisor had so far demonstrated good quality work in application and workmanship. Hence, they are granted as pre-qualified applicator for the Saudi BASF range of products as described above.

This pre-qualification is valid for one year from this date and subject to remain under constant monitoring during using Saudi BASF - The Chemical Company products. This pre-qualification can be withdrawn during the duration of this period, if the quality of application is not to BASF's Standards and Guidelines.

For and on behalf of
Saudi BASF Co. Ltd.

Technical Manager

Saudi BASF
For Building Materials Co. Ltd.

القسم الفني
Technical Department

A Private Company incorporated with limited liability in the Kingdom of Saudi Arabia
Paid up Share Capital SR 5.5 Million
Commercial Registration No. 2050037620
COC Membership No: 476



CERTIFICATION

Sika Saudi Arabia Co. Ltd.
شركة سيكا العربية السعودية المحدودة

CERTIFICATE

This is to confirm that *Gulf Crete LTD Co.*
P O Box 20647
Riyadh 11465
Is an approved applicator for the following applications of Sika®-Products.
PVC Membrane, Cementitious & Epoxy Waterproofing

The Approved Applicator *Gulf Crete*, has received practical training in the proper storing, preparation and application of the Sika®-Products.

The approved Applicator is aware of the relevant Sika® Product Data Sheets and all other technical documentation.

This Confirmation is valid for one year from its date of issue and may be renewed subject to the Approved Applicator successfully completing any training courses required by Sika. Sika is not responsible for the Approved Applicator's compliance with Sika's guidelines or training instructions or any other requirements of third parties. Sika is not liable for any acts or omissions of the Approved Applicator arising in any way, including, but not limited to, any breach of contract; or any distort (including negligence); or any breach of statutory duty.

THIS CERTIFICATE IS VALID FOR THE PERIOD 01/06/14 TO 01/06/2015

Sincerely,

Emad Al Ashqar,
Senior Sales Manager,
Sika Saudi Arabia,
Riyadh,
Mobile # 0505 363 569













Jeddah
P.O. Box 112356
Jeddah 21311
Saudi Arabia
Tel: +966-2-8827879
Fax: +966-2-8821272
C.R. No: 402003496
sika.jeddah@sika.com

Dammam
P.O.Box 74577
Dammam 31952
Saudi Arabia
Tel: +966-3-8472448
Fax: +966-3-8471763
sika.dammam@sika.com

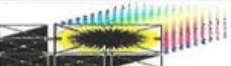
Riyadh
P.O.Box 58647
Riyadh 11583
Saudi Arabia
Tel: +966-6-111002230
Fax: +966-6-111002881
sika.riyadh@sika.com

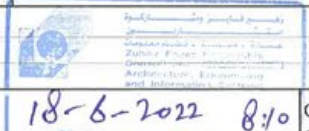
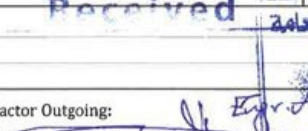
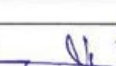
Innovation & since
Consistency 1910



							
Client : National Housing Company		PMC : Dar al-handasah		Consultant : Zuhair Fayeze		General Contractor : ANSAB CO.	
SUPPLIER PREQUALIFICATIONS & MATERIAL SUBMITTAL							
AR	ME	CV	LA	M2P-ANB-MOCKUP-MAT-ARCH-072 - REV 00			
ST	EE	QS	OT	Date : 6/16/2022	Contract Drawing No.		
To: Zuhair Fayeze				From: ANSAB CO.			
Material Details				List of Enclosure			
Application: MOCKUP VILLA Specification Ref.: 075552 - 072119 BOQ Reference(s): DIV - 07 Drawing Ref.:				<input checked="" type="checkbox"/> Copy of Related Drawing			
Specified Material ROOFING INSULATION SYSTEM				<input checked="" type="checkbox"/> Compliance Statement			
Proposed Material شركة أنساب للمقاولات العامة				<input checked="" type="checkbox"/> Catalogue			
Manufacturer / Local Supplier GULF CRETE LTD.				<input checked="" type="checkbox"/> Others (Specify)			
Reasons for Alternative (if any) مشروع تطوير منضبط مسبق 25/6/2022				<input checked="" type="checkbox"/> Test Certificate			
Contractor's Remarks:  				شركة أنساب للمقاولات العامة			
Contractor Incoming : Signature: 18-6-2022 8:10		Contractor Outgoing : Signature: 					
Consultant Comments: <i># The submitted pre-qualification for the proposed supplier has been reviewed & found acceptable subject to client approval -</i> <i># For Ms Contractor to submit compliance status & samples of materials for review & client approval -</i> <i>* Mock-up samples on site to be applied after the final approval of material by client.</i> <i># Method of statement (MOS) to be provided prior start mock-up onsite.</i>  22/06/2022							
For:ZFP Signature: 		Date: 23 June 2022					
ACTION CODE: <input checked="" type="checkbox"/> A = Approved <input type="checkbox"/> C = Resubmit as Noted <input type="checkbox"/> E = No action taken <input type="checkbox"/> B = Approved as noted <input type="checkbox"/> D = Disapproved <input type="checkbox"/> F = Retained for Info.							

CERTIFICATION



Dated: 15th June 2015

To whom it may concern,

This is to certify that M/S Gulf Crete is working at Centro Riyadh Hotel project under SCC supervision for water proofing & epoxy coating with the satisfaction of SCC site management.

Moreover, we are satisfied with the method of statement and standard of work done at site & comply with the specification of work.





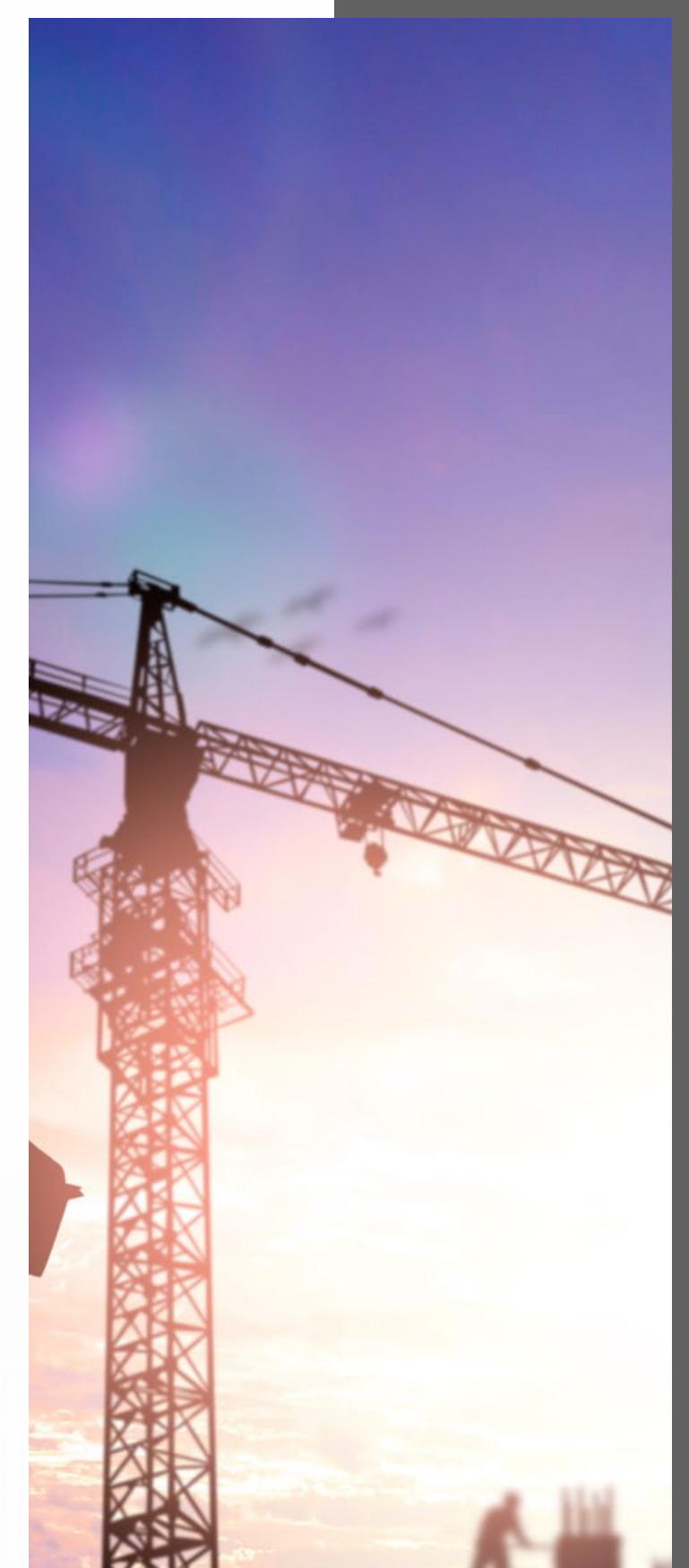

We wish them all success in future.

Thank you and best regards,



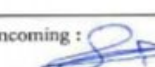

Eng. Nicolas Haddad
 SCC Project Manager
 Centro Riyadh Hotel project.

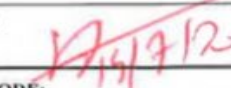

							
Client : National Housing Company		PMC : Dar al-handasah		Consultant : Khatib & Alami		General Contractor : Tamimi Global Company Ltd.	
MATERIAL SUBMITTAL							
AR	ME	CV	LA	Submittal No.	M	S	- 2 2 2 Rev. 0 0
ST	EE	QS	OT	Date : 7/13/2020	Contract Drawing No.		
To: Khatib & Alami				From: Tamimi Global Company Ltd.			
List of Enclosure							
Specs / BOQ / Drawings Reference		Application for: Wet Areas Waterproofing System. Specification Ref. as per project specification (Sec.071416). BOQ Reference(s): MURCIA BOQ Drawing Ref:		<input type="checkbox"/>	Copy of Related Drawing		
Specified Material		Cementitious Waterproofing System.		<input checked="" type="checkbox"/>	Compliance Statement		
Proposed Material		Cementitious Waterproofing System.		<input checked="" type="checkbox"/>	Catalogue		
Manufacturer / Local Supplier		GULF CRETE LTD THE SPECIALIZED.CO(Material from BASF).		<input checked="" type="checkbox"/>	Others (Specify)		
Reasons for Alternative (if any)				<input checked="" type="checkbox"/>	Test Certificate		
Contractor's Remarks:							
							
Contractor Incoming : Signature:  Date: 2050004970				Contractor Outgoing: Signature: _____ Date: _____			
Consultant Comments:							
<p>• MASTER TILE WP 667 IS APPROVED AS A WATERPROOF MATERIAL FOR WET AREAS ONLY.</p> <p>• MOCKUP SAMPLE WITH TEST AS PER ASTM C856 TO BE DONE PRIOR DELIVERY.</p>							
							
For K&A: Signature:  Date: 15/7/20							
ACTION CODE: <input type="checkbox"/> A = Approved <input checked="" type="checkbox"/> B = Approved as noted <input type="checkbox"/> C = Resubmit as Noted <input type="checkbox"/> D = Disapproved <input type="checkbox"/> E = No action taken <input type="checkbox"/> F = Retained for Info.							

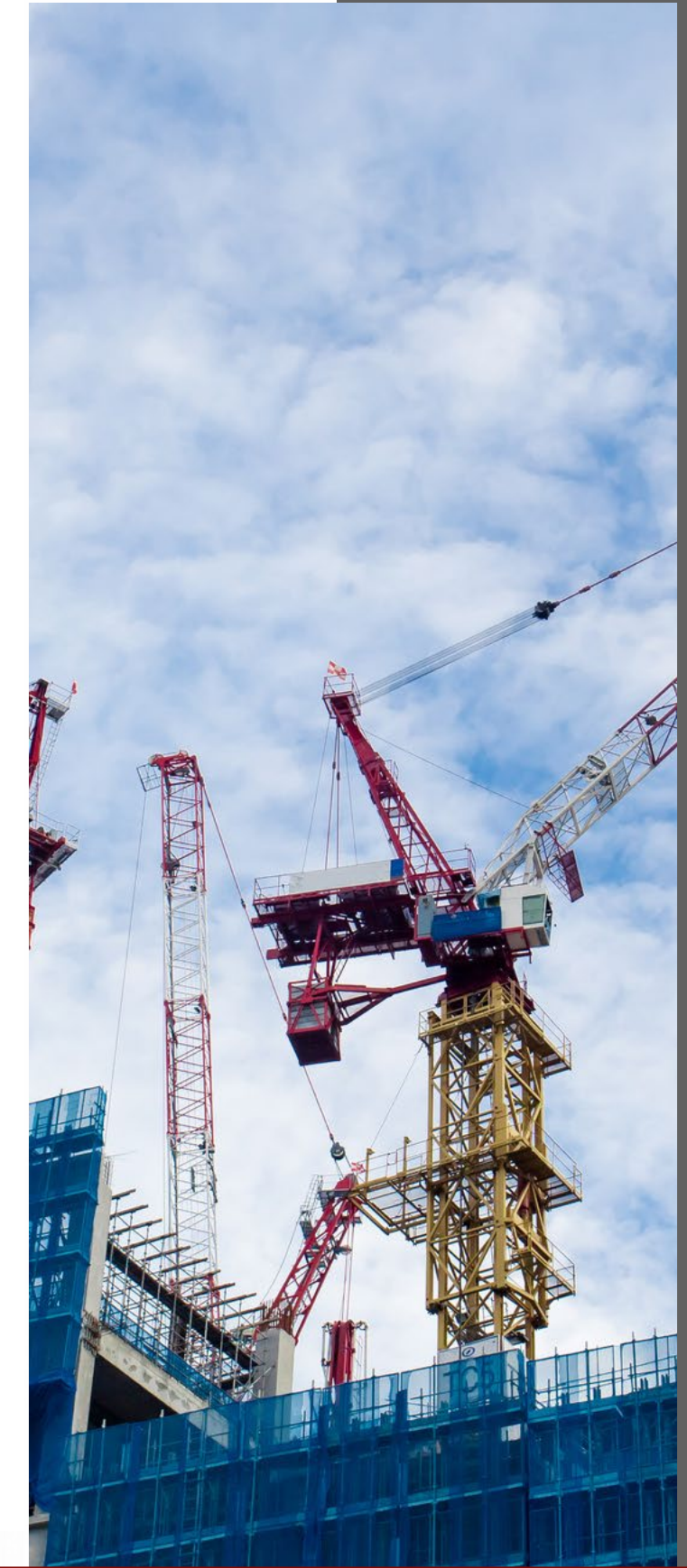
							
Client : National Housing Company		PMC : Dar al-handasah		Consultant : Khatib & Alami		General Contractor : Tamimi Global Company Ltd.	
MATERIAL SUBMITTAL							
AR	ME	CV	LA	Submittal No.	M	S	- 2 3 0 Rev. 0 0
ST	EE	QS	OT	Date : 7/13/2020	Contract Drawing No.		
To: Khatib & Alami				From: Tamimi Global Company Ltd.			
List of Enclosure							
Specs / BOQ / Drawings Reference		Application for: Wet Areas Waterproofing System. Specification Ref. as per project specification (Sec.071416). BOQ Reference(s): MURCIA BOQ Drawing Ref:		<input type="checkbox"/>	Copy of Related Drawing		
Specified Material		Cementitious Waterproofing System.		<input checked="" type="checkbox"/>	Compliance Statement		
Proposed Material		Cementitious Waterproofing System.		<input checked="" type="checkbox"/>	Catalogue		
Manufacturer / Local Supplier		GULF CRETE LTD THE SPECIALIZED.CO(Material from FOSROC)		<input checked="" type="checkbox"/>	Others (Specify)		
Reasons for Alternative (if any)				<input checked="" type="checkbox"/>	Test Certificate		
Contractor's Remarks:							
							
Contractor Incoming : Signature:  Date: 2050004970				Contractor Outgoing: Signature: _____ Date: _____			
Consultant Comments:							
<p>• NITOCUTE CM 210 IS APPROVED AS A WATERPROOF MATERIAL FOR WET AREAS ONLY.</p> <p>• MOCKUP SAMPLE WITH TEST AS PER ASTM C856 TO BE DONE PRIOR DELIVERY.</p>							
							
For K&A: Signature:  Date: 15/7/20							
ACTION CODE: <input type="checkbox"/> A = Approved <input checked="" type="checkbox"/> B = Approved as noted <input type="checkbox"/> C = Resubmit as Noted <input type="checkbox"/> D = Disapproved <input type="checkbox"/> E = No action taken <input type="checkbox"/> F = Retained for Info.							



Material Submittal Form			
Submittal Ref:	NHC-KAT-PMO-MAT-CI-0081	Rev No:	00
Date:	07/07/2020		
Program Title:	Developmental Housing Project of MOH WAVE		
Project Title:	All Projects		
The Employer:	NHC		
Third party:	Saudi Arabian Parsons Ltd.-SAPL		
Consultant:	OMRAN Engineering and Consultant		
Contractor:	Kattera Saudi Arabian LLC		

RECEIVED
 07 JUL 2020
 OMRAN Engineering Consultants

Guidance notes:
 The submission should only include materials which are compliant with the SOPR and CODE requirements and have been reviewed and coordinated between the Contractor and Designer (and Engineer if applicable) and should include any authorised variations/changes as instructed.

Material Details
 Notes: SAPL review will recommend either Objection or No Objection to each item. Non-Objected shall be issued to the NHC with the recommendation to approve. Objected shall be returned to the Contractor with an Objection report. This sheet must be signed by any specialist sub-contractor applicable to the Material element Design/Production (e.g. Pre-cast panel manufacturer)

Proposed by:	The Contractor	The Consultant (Designer & The Engineer)	Specialist/Sub-Contractor
Sign/Stamp:			

Material Information & Checklist
 SAPL REVIEW
 Objection No Objection



Location /element Ref:	Specified Material:	Proposed Material:	SOPR/CODE Ref(s):	Manufacturer & Product code ref:	Remarks/Notes:
All Projects	Waterproofing	Roof Waterproofing System (Including Material Datasheet, Method statement)		Supplier: Gulf Crete Ltd.	
					Sample (available) Photo Attached (Sample available in Kattera office, we will provide upon request.)

THE ENGINEER*	Review date:	Approved Date:
	Signed:	Print Name:
Third Party	Review date:	Recommendation Date:
	Signed:	Print Name:
The Employer	Review date:	Review Date:
	Signed:	Print Name:

NHC Program - Material Submittal Form Company Confidential
RECEIVED
 27 JUL 2020
 OMRAN Engineering Consultants

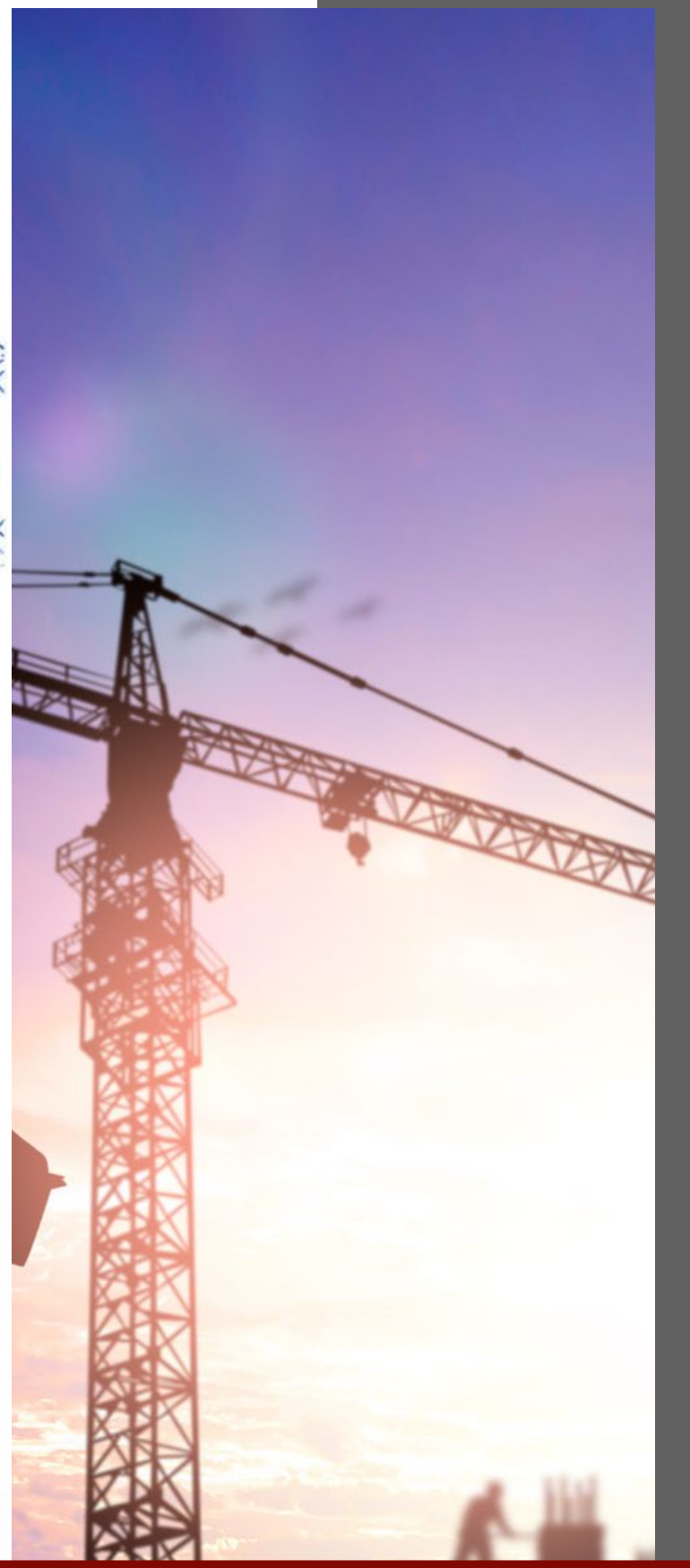
Client : National Housing Company PMC : Dar al-handasah Consultant : Khatib & Alami General Contractor : Tamimi Global Company Ltd.																												
SUPPLIER PRE-QUALIFICATION																												
<table border="1"> <tr> <td>AR</td><td>ME</td><td>CV</td><td>LA</td><td>Submittal No.</td><td>S</td><td>P</td><td>-</td><td>1</td><td>2</td><td>4</td><td>Rev.</td><td>0</td><td>0</td> </tr> <tr> <td>ST</td><td>EE</td><td>QS</td><td>OT</td><td>Date :</td><td colspan="3">7/13/2020</td><td colspan="6">Contract Drawing No.</td> </tr> </table>	AR	ME	CV	LA	Submittal No.	S	P	-	1	2	4	Rev.	0	0	ST	EE	QS	OT	Date :	7/13/2020			Contract Drawing No.					
AR	ME	CV	LA	Submittal No.	S	P	-	1	2	4	Rev.	0	0															
ST	EE	QS	OT	Date :	7/13/2020			Contract Drawing No.																				
To: Khatib & Alami From: Tamimi Global Company Ltd.																												
<table border="1"> <thead> <tr> <th>Supplier Description</th> <th>Attachments</th> </tr> </thead> <tbody> <tr> <td>Name: GULF CRETE LTD THE SPECIALIZED CO.</td> <td><input checked="" type="checkbox"/> Company Profile</td> </tr> <tr> <td>Telephone No.: 0114655034</td> <td><input checked="" type="checkbox"/> Valid Commercial Registration Certificate</td> </tr> <tr> <td>Address: RIYADH-KSA</td> <td><input checked="" type="checkbox"/> Valid Membership of Chamber of Commerce</td> </tr> <tr> <td>Person in Charge and His Mobile No: 599281826</td> <td><input checked="" type="checkbox"/> Valid VAT Registration Certificate</td> </tr> <tr> <td>Supplier's Qualifying Log:</td> <td><input checked="" type="checkbox"/> Valid Zakat & Tax Certificate</td> </tr> <tr> <td>Years of Experience (In Total): 20 YEARS</td> <td><input checked="" type="checkbox"/> Valid General Organization of Social Insurance</td> </tr> <tr> <td>Years of Experience In Saudi Arabia: 20 YEARS</td> <td><input checked="" type="checkbox"/> Valid Saudization Certificate</td> </tr> <tr> <td></td> <td><input type="checkbox"/> Valid Contractor Classification Certificate</td> </tr> <tr> <td></td> <td><input type="checkbox"/> Valid SASO Certificate</td> </tr> <tr> <td></td> <td><input checked="" type="checkbox"/> Authorized Signatory of Responsible Person</td> </tr> </tbody> </table>	Supplier Description	Attachments	Name: GULF CRETE LTD THE SPECIALIZED CO.	<input checked="" type="checkbox"/> Company Profile	Telephone No.: 0114655034	<input checked="" type="checkbox"/> Valid Commercial Registration Certificate	Address: RIYADH-KSA	<input checked="" type="checkbox"/> Valid Membership of Chamber of Commerce	Person in Charge and His Mobile No: 599281826	<input checked="" type="checkbox"/> Valid VAT Registration Certificate	Supplier's Qualifying Log:	<input checked="" type="checkbox"/> Valid Zakat & Tax Certificate	Years of Experience (In Total): 20 YEARS	<input checked="" type="checkbox"/> Valid General Organization of Social Insurance	Years of Experience In Saudi Arabia: 20 YEARS	<input checked="" type="checkbox"/> Valid Saudization Certificate		<input type="checkbox"/> Valid Contractor Classification Certificate		<input type="checkbox"/> Valid SASO Certificate		<input checked="" type="checkbox"/> Authorized Signatory of Responsible Person						
Supplier Description	Attachments																											
Name: GULF CRETE LTD THE SPECIALIZED CO.	<input checked="" type="checkbox"/> Company Profile																											
Telephone No.: 0114655034	<input checked="" type="checkbox"/> Valid Commercial Registration Certificate																											
Address: RIYADH-KSA	<input checked="" type="checkbox"/> Valid Membership of Chamber of Commerce																											
Person in Charge and His Mobile No: 599281826	<input checked="" type="checkbox"/> Valid VAT Registration Certificate																											
Supplier's Qualifying Log:	<input checked="" type="checkbox"/> Valid Zakat & Tax Certificate																											
Years of Experience (In Total): 20 YEARS	<input checked="" type="checkbox"/> Valid General Organization of Social Insurance																											
Years of Experience In Saudi Arabia: 20 YEARS	<input checked="" type="checkbox"/> Valid Saudization Certificate																											
	<input type="checkbox"/> Valid Contractor Classification Certificate																											
	<input type="checkbox"/> Valid SASO Certificate																											
	<input checked="" type="checkbox"/> Authorized Signatory of Responsible Person																											
Material to Supply: WATERPROOFING, INSULATION, FIREPROOFING, CONCRETE REPAIRS, AND FLOOR COATINGS Approval of Supplier does not relieve contractor of his responsibilities under contract's terms.																												
Contractor's Remarks: Hardcopy of company profil (3) , cd -softcopy (3) TAMIMI GLOBAL CO. L. 2050004970																												
Contractor Incoming: Signature: Date: 14/7/20 Contractor Outgoing: Signature: _____ Date: _____																												
Consultant Comments: MURCIA HOUSING PROJECT - SUPPLIER APPROVED TO PROVIDE THE ABOVE MENTIONED MATERIAL. - MATERIAL TO BE PROVIDED AND AREA OF APPLICATION IS SUBJECT TO CONSULTANT APPROVAL. - ANY MISSING CERTIFICATE, OR OUTDATED CERTIFICATE TO BE PROVIDED																												
For K&A : Signature: Date: 14/7/20																												
ACTION CODE: A = Approved <input type="checkbox"/> C = Resubmit as Noted <input type="checkbox"/> B = Approved as noted <input checked="" type="checkbox"/> D = Disapproved <input type="checkbox"/>																												
NOTE: The Client - National Housing Company (NHC) has the authority to approve/disapprove the supplier without any objection from _____ sides.																												



							
Client : National Housing Company		PMC : Dar al-handasah		Consultant : Khatib & Alami		General Contractor : Tamimi Global Company Ltd.	
SUPPLIER PRE-QUALIFICATION							
AR	ME	CV	LA	Submittal No.	S	P	-
ST	EE	QS	OT	Date : 7/13/2020	1	2	4
To: Khatib & Alami				From: Tamimi Global Company Ltd.			
Supplier Description				Attachments			
Name: GULF CRETE LTD THE SPECIALIZED CO.				<input checked="" type="checkbox"/> Company Profile			
Telephone No.: 0114655034				<input checked="" type="checkbox"/> Valid Commercial Registration Certificate			
Address: RIYADH-KSA				<input checked="" type="checkbox"/> Valid Membership of Chamber of Commerce			
Person in Charge and His Mobile No: 599281826				<input checked="" type="checkbox"/> Valid VAT Registration Certificate			
Supplier's Qualifying Log:				<input checked="" type="checkbox"/> Valid Zakat & Tax Certificate			
Years of Experience (In Total): 20 YEARS				<input checked="" type="checkbox"/> Valid General Organization of Social Insurance			
Years of Experience In Saudi Arabia: 20 YEARS				<input checked="" type="checkbox"/> Valid Saudization Certificate			
				<input type="checkbox"/> Valid Contractor Classification Certificate			
				<input type="checkbox"/> Valid SASO Certificate			
				<input checked="" type="checkbox"/> Authorized Signatory of Responsible Person			
Material to Supply: WATERPROOFING, INSULATION, FIREPROOFING, CONCRETE REPAIRS, AND FLOOR COATINGS							
Approval of Supplier does not relieve contractor of his responsibilities under contract's terms.							
Contractor's Remarks: Hardcopy of company profil (3) , cd -softcopy (3) TAMIMI GLOBAL CO. L. 2050004970							
Contractor Incoming Signature:  Date: 14/7/20				Contractor Outgoing Signature: _____ Date: _____			
Consultant Comments: MURCIA HOUSING PROJECT							
<p><i>SUPPLIER APPROVED TO PROVIDE THE ABOVE MENTIONED MATERIAL.</i></p> <p><i>MATERIAL TO BE PROVIDED AND AREA OF APPLICATION IS SUBJECT TO CONSULTANT APPROVAL.</i></p> <p><i>ANY MISSING CERTIFICATE, OR OUTDATED CERTIFICATE TO BE PROVIDED</i></p>							
For K&A : Signature:  Date: 14/7/20							
ACTION CODE: A = Approved <input type="checkbox"/> C = Resubmit as Noted <input type="checkbox"/> B = Approved as noted <input checked="" type="checkbox"/> D = Disapproved <input type="checkbox"/>							
NOTE: The Client - National Housing Company (NHC) has the authority to approve/disapprove the supplier without any objection from all sides.							

  			
PREQUALIFICATION APPROVAL REQUEST			
Project:	Riyadh Township - Phase 01a - (Southern)	Ref No.:	TNHP-RY-RY1-A01-RW002-SPJ-CIV-PQD-00018
Client:	ROSHN	Rev. No.:	R00
Engineer:	Akaria Hanmi for Project Management	Submittal:	Civil Date: 24-Jan-21
Contractor:	Shapoorji Pallonji Mideast (L.L.C)	Purpose/Use:	Villa
PREQUALIFICATION DESCRIPTION			
Description:	Waterproofing <input checked="" type="checkbox"/>	Company Name:	Gulf Crete Ltd for Contracting Company
Project Name.:	Riyadh Township - Phase 01a - (Southern)	Contract Ref:	RW002
Attachments:	<input checked="" type="checkbox"/> GOSI Zakat <input checked="" type="checkbox"/> Saudization Certificate <input checked="" type="checkbox"/> Ministry of Industry <input checked="" type="checkbox"/> Chamber of Commerce <input type="checkbox"/> SASO Specilized Lab Tests Certificate <input type="checkbox"/> Technical Catalog <input checked="" type="checkbox"/> Other Certificates (ISO, ,etc.) <input type="checkbox"/> Certificate of Original <input type="checkbox"/> Warranty Certificate		
MANUFACTURER DETAILS		SUPPLIER DETAILS	
Company Name: Gulf Crete Ltd for Contracting Company		Company Name: Gulf Crete Ltd for Contracting Company	
Address: KSA		Address: KSA	
Discipline/Trade: Civil / CIV		Specification: 07 13 55 & 07 11 50	
Project Name.: Southern Building: Villa		BOQ Ref. No.: -	
For the Contractor:			
Name: MURUGAN PAPAAYAN		Signature:  Date: 24.01-2021	
ENGINEER REVIEW			
Remarks: Pre-qualification of Gulf Crete Ltd is accepted. Material submittal required with sample & system warranty as per project requirement. For specific use only (Waterproofing)			
Name: _____ Signature: _____ Date: _____			
Status Code: <input type="checkbox"/> Approved (A) <input checked="" type="checkbox"/> Approved with Comments (B) <input type="checkbox"/> Revise & Resubmit (C) <input type="checkbox"/> Rejected (D)			
PM (CORE TEAM) REVIEW			
All legal documents should be valid throughout the life of the project.			
Name: ABSEER UDDIHA		Signature:  Date: 25/01/2021	
CM Comements:		CLIENT'S APPROVAL (If Required) <input type="checkbox"/> Yes <input type="checkbox"/> No	
Remarks:		Remarks:	
Name: _____ Signature: _____ Date: 24/1/2021		Name: _____ Signature: _____ Date: _____	
Approval shall not relieve the Contractor of its obligations and liabilities under the Contract or constitute authorization of any change to Contract Documents, and therefore, shall not imply on recognition whatsoever of additional time or cost to the Contractor.			
			

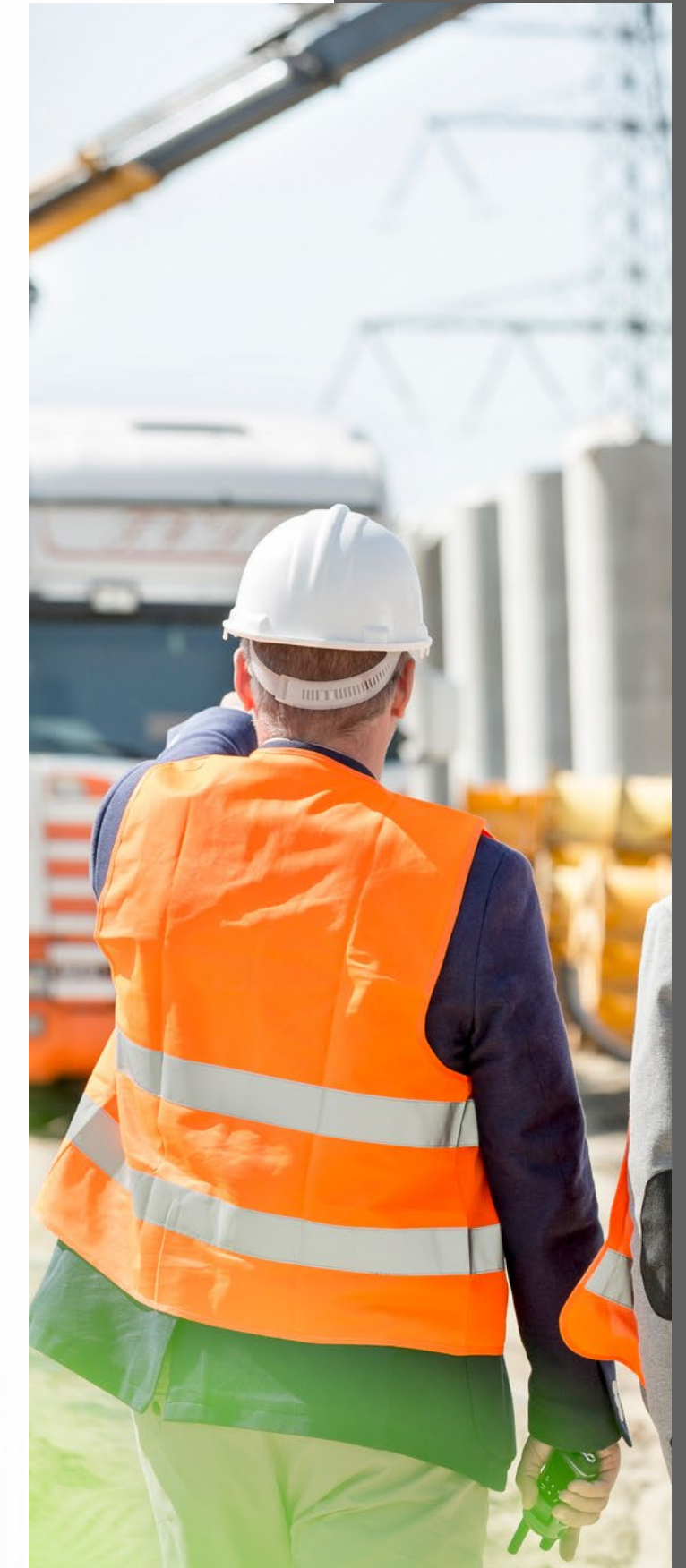



شركة المطاط الفني المحدودة
Techno Rubber Company Limited

Date: 12/06/2022

Sub: Approved Applicator Certificate

TO WHOMSOEVER IT MAY CONCERN

This is to inform the concerned that **Gulf Crete Ltd.** is an approved applicator for **TECHNO RUBBER EPDM** waterproofing system. They have sufficient experience in installing **TECHNO RUBBER EPDM** waterproofing system and they are eligible for our standard roofing warranty.

For Techno Rubber Company Limited

Authorized Signatory
Saleh Alhashem



C.R. 2050044267
Second Industrial City
Tel.: +966 13 8123333
Fax: +966 13 8123322

س.ر. ٢٠٥٠٠٤٤٢٦٧
المدينة الصناعية الثانية
هاتف: +٩٦٦ ١٣ ٨١٢٣٣٣٣
فاكس: +٩٦٦ ١٣ ٨١٢٣٣٢٢

Arabian Chemical Company Ltd.
(Polystyrene)

A Joint Venture of E. A. Juffali & Brothers and The Dow Chemical Co.
Paid-up Capital S.R 7,500,000
C.R. No. 4030047091



الشركة العربية الكيماوية المحدودة
(بوليستيرين)

شركة متضامنة بين شركة إبراهيم الجفالي وإخوانه وشركة داو كامييل
مدفوع بالكامل ٧.٥٠٠.٠٠٠ ريال سعودي
سجل تجاري رقم ٤٠٣٠٠٤٧٠٩١

Date: 13-July-2022
Ref #: AZ/GC/136/22

TO WHOM IT MAY CONCERN

We, The Arabian Chemical Company (Polystyrene) Ltd - (ACC), one of EA Juffali & Brothers group of companies, do hereby certify that M/S "Gulf Crete Ltd. Co." have a good and adequate experience in installing our Insulation Products in Saudi Arabia. They are one of our approved Installing Contractors.

This Certificate does not imply any responsibility on our part for quality control of workmanship or any contractual liabilities.

Validity of this certificate till end of 2022 and is subject to ACC's regular and annual evaluation.

إلى من يهمه الأمر

تشهد الشركة العربية الكيماوية (بوليستيرين) المحدودة إحدى شركات إبراهيم الجفالي وإخوانه، بأن شركة "خليج الخرسانة المحدودة" هي شركة متخصصة و معتمدة في مجال تركيب أنظمة العزل التي تنتجها الشركة العربية الكيماوية ولديها خبرة جيدة و مناسبة لتنفيذ المشاريع داخل المملكة العربية السعودية.

أعطيت هذه الشهادة بناء على طلبهم دون أدنى مسؤولية على الشركة العربية الكيماوية المحدودة فيما يتعلق بأي أضرار مترتبة على عيوب قد تنشأ عن أخطاء في تركيب المنتجات أو خلافه.

هذه الشهادة صالحة حتى نهاية عام 2022 وتخضع للتقييم السنوي المعتاد.

Best Regards
The Arabian Chemical Company
(Polystyrene) Ltd

Eng. Ahmad Zimmo
National Sales Manager



Sales Office, E.A. Juffali & Bros., Exclusive Agent for Arabian Chemical Co. Ltd.

Jeddah: P.O.Box 5728, Jeddah 21432 - Tel. (012) 667 4818 / 667 4620 - Fax (012) 660 9028
Riyadh: P.O.Box 66, Riyadh 11411 - Tel. (011) 465 5272 / 465 5274 - Fax (011) 465 5274
Dammam: P.O.Box 5348, Dammam 31422 - Tel. (013) 827 1652 / 827 2077 - Fax (013) 827 3623



Factory Location: Jeddah Industrial Estate (3rd Phase)

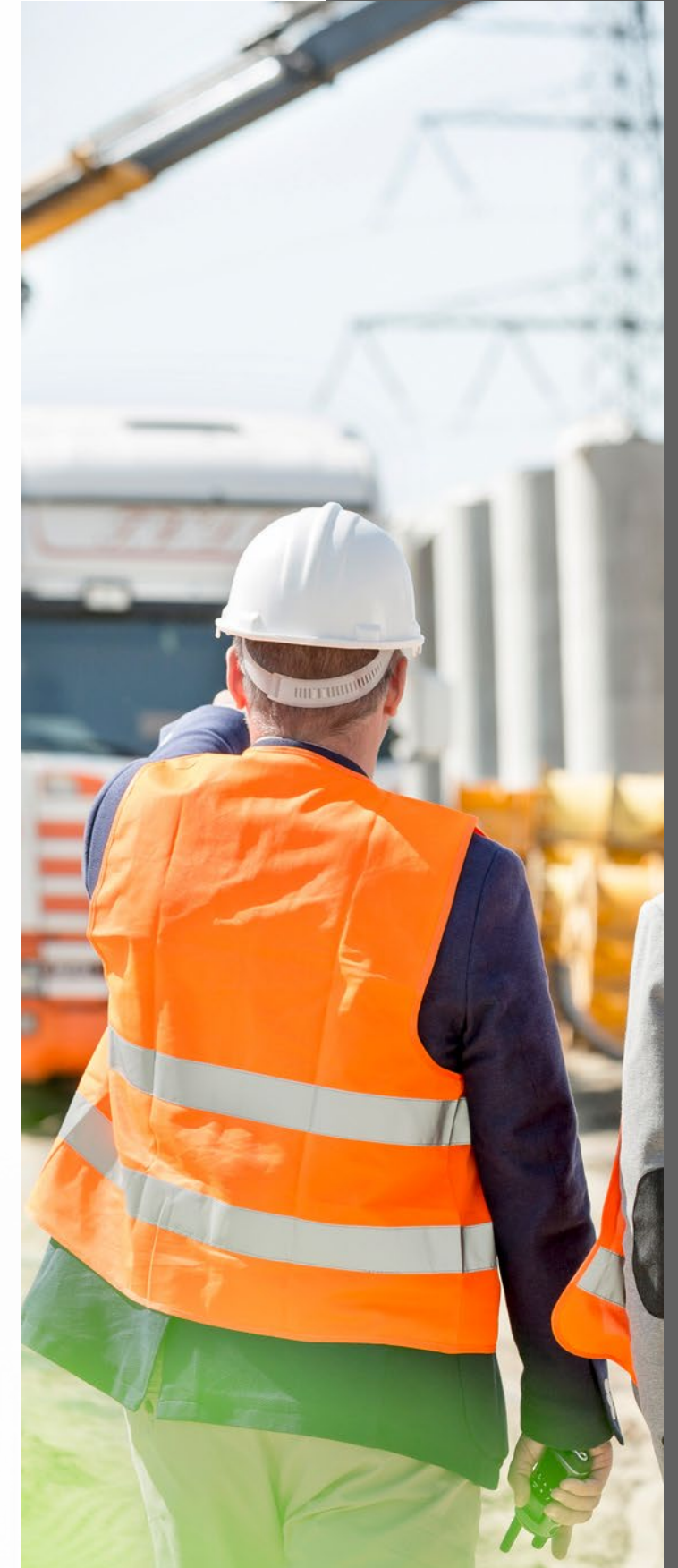

CERTIFICATE

FOR RECOMMENDED SIKA APPLICATORS

This is to certify that

GULF CRETE CONTRACTING

Has successfully executed many Projects after having passed the application training of various Sika systems and is Recommended Sika Applicator for

Concrete repair and protection, Waterproofing (PVC membranes loose laid and full compartment system), Cementitious, Resins, Combiflex range), Joint Sealants and Industrial flooring.

This comprehensive training consisted of practical instructions about proper storage, preparation and application of Sika products.

The recommended applicator has been provided with the relevant Sika Product Data Sheets and all other technical documentation.

This confirmation is valid until the date of expiry below and may be renewed subject to the Recommended Applicator successfully completing any training courses required by Sika. The Recommended Applicator is responsible for ensuring full compliance by its employees with Sika's guidelines, training instructions and any other requirements of third parties.

Sika is not responsible for any loss or damage suffered by any third party as a result of any acts or omissions of the Recommended Applicator arising in anyway, including but not limited to breach of contract, misrepresentation, failure to comply with applicable laws or any other tort including negligence.

Sika Saudi Arabia,

Issuing Date: January 01, 2016 Expiry Date: December 31, 2016



Shehadeh Salman
T.M Waterproofing Manager
Central Region
Sika Saudi Arabia



Emad Al Asqar
Sr. Sales Manager
Central Region
Sika Saudi Arabia

This Recommendation does not assume responsibility for the correct storage, mixing or use of these Products. Sika shall not be liable for damage to persons or property, loss of business or profit or any other direct, indirect, special or consequential damage so caused by the Recommended Applicator. Sika shall also not be responsible for use of these Products in a manner to infringe on any patent or other intellectual property rights held by others. Sika's liability is limited to the quality only of the supplied material. Any failures due to wrong application or storage not in accordance with the given guidelines as stated on the latest Technical Data Sheets, as well as structural or mechanical failures are excluded herein.



BUILDING TRUST





BASF
We create chemistry

شركة بي أس إف السعودية - مواد البناء المحدودة
برج العثمان الطابق رقم 14
طريق الملك سعود، المنطقة، الخبر رقم 31941
ص. ب. 1884، الخبر 31941 - المملكة العربية السعودية
Saudi BASF For Building Materials Co. Ltd.
Al-Othman Business Tower 14th Floor
King Saud Road, Al Qashlah, Dhahran 34232
P.O. Box 1884, Al Khobar 31952

26th February 2017
Ref:JT/L001/26022017

PRE – QUALIFICATION CERTIFICATE OF CONFIRMITY

This is to acknowledge that **M/S Gulf Crete Ltd. Contracting Company.** Has submitted company profile and other relevant documents to SAUDI BASF, For Building Materials Co Ltd for authorized applicator approval purpose. Hereby we are certifying that they are under review and authorized to apply our products as below.

- WATERPROOFING SYSTEMS
- Epoxy and PU flooring system
- Concrete Repair

Further to their team of supervisor had maintained good quality work. Hence, they are prequalified applicators to the Saudi BASF range of products as described above.

The pre-qualification is valid for one year from this date and subject to remain under constant monitoring for using **Saudi BASF – The Chemical Company** products. This pre-qualification can be withdrawn, if the quality of application is not to BASF's satisfaction.

For and on Behalf of
Saudi BASF Co.Ltd.



Jignesh Thakkar.
Technical Manager

شركة بي أس إف السعودية لمواد البناء المحدودة
Saudi BASF
for Building Mts. Co. Ltd.
قسم المختبرات والجودة
Technical Department

Head Office:
Tel : +966 13 853 8600, 13 812 1140 هاتفنا: +٩٦٦ ١٣ ٨٥٣ ٨٦٠٠/١٣ ٨١٢ ١١٤٠
Fax: +966 13 852 8671, 13 812 1822 فاكسنا: +٩٦٦ ١٣ ٨٥٢ ٨٦٧٧/١٣ ٨١٢ ١٨٢٢
www.master-builders-solutions.sa
enquiry@saudi.basf.com



MASTER®
BUILDERS
SOLUTIONS

شركة ذات مسئولية محدودة في المملكة العربية السعودية رأس المال المدفوع 11 مليون ريال سجل تجاري رقم ٢٠٠٠٢٧٦٢٠
الكتاب التسجيل طريق رقم ٥٨ المنطقة الصناعية الثانية، الدمام، المملكة العربية السعودية هاتفنا: +٩٦٦ ١٣ ٨١٢ ١١٢١ فاكسنا: +٩٦٦ ١٣ ٨١٢ ٢٢٦٦
A private Company Incorporated with limited liability in the KSA, Paid Up Share Capital SR 11 Million, Commercial Registration No. 2050037620
Registered Office, Street No 58, Dammam 2nd Industrial Area, Saudi Arabia, Tel : +966 13 812 1231. Fax : +966 13 812 3269



شركة دي سي بي السعودية

DCP Saudi

Date: 22nd November 2014

TO WHOM IT MAY CONCERN

This is to certify that **M/s Gulf Crete Ltd.** is our approved and certified applicator for all **DCP Saudi Company** Products for following ranges:

- Waterproofing system
- Joint Sealant
- Protective coating for concrete and masonry
- Epoxy Flooring
- Concrete repair
- Injection

This certificate is issued upon their request and without any liabilities on **DCP Saudi Company**, and valid for Six months from the date of issuance of this certificate.

Yours Sincerely,



For
DCP Saudi Co.

DCP Saudi
PO Box 64241 Riyadh 11576
Kingdom of Saudi Arabia
Tel : + 966 11 461 2003
Fax : + 966 11 279 2059
Info.saudi@dcp-int.com
www.dcp-int.com

Capital Paid: 1000000 S.R CR. # 1010267930 Licence: 217074 رقم الترخيص: ٢١٧٠٧٤ ص.ت. ١٠١٠٢١٧٩٣٠ ريال سعودي ١٠٠٠٠٠٠ رأس المال المدفوع

expertise quality full-range

Msg: 7024/RWA/17 Our Ref:
Via: Email Date: 19-Jun-17
Your Ref: No. of Pages: 1

To Whom It May Concern

Subject : Authorized Applicator Certificate
Project : Wadi Al Hada Compound -Riyadh

This is to confirm that M/s Gulf Crete Ltd. Co., Kingdom of Saudi Arabia, based upon its experience, knowledge of product and expertise in application has met the criteria established and is hereby certified as an Authorized Applicator for Carlisle Sure-Seal, EPDM waterproofing system.

This certificate serves the above mentioned project only and it is valid for 2 (Two) years from issuing date.

Best Regards,
Rabih Adra
Technical Manager – Saudi Arabia



شركة صناعات المواد العازلة للماء ديرمابيت المحدودة
DWI, DERMABIT Waterproofing Industries Co. Ltd.

Fully Paid up Capital S. R. 11.5 Million
C. R. : 1010048740

RIYADH BRANCH : P. O. BOX 5945,
RIYADH 11432 - SAUDI ARABIA
TEL.: (011) 4645988 FAX : (011) 4634100
Email : dermabit@dermabit.com.sa
Website : http://www.dermabit.net

Date : 2/2/2020
Ref.: 20/22

رأس المال المدفوع بالكامل 11,5 مليون ريال سعودي
سجل تجاري : ١٠١٠٠٤٨٧٤٠

فرع الرياض : ص.ب ٥٩٤٥
الرياض ١١٤٣٢ - المنطقة العربية السعودية
تلفون : ٤٦٤٥٩٨٨ (٠١١) فاكس : ٤٦٣٤١٠٠ (٠١١)
بريد إلكتروني : dermabit@dermabit.com.sa
الترقيم البريدي : http://www.dermabit.net

التاريخ : 2020/2/2 م
الرقم : 22/20



TO WHOM IT MAY CONCERN

We, DWI, Dermabit Waterproofing Industries Co., Ltd, 100% Saudi manufacturer of waterproofing systems, do hereby certify that M/S.GULF CRETE CONTRACTING. - Riyadh, have a good and an adequate experience for a long period in installing our waterproofing products in Saudi Arabia. They are one of our approved waterproofing contractors.

This certificate does not imply any responsibility on our part for quality control of workmanship or any contractual liabilities.

Validity of this certificate is for one year from the above mentioned date and is subject to Dermabit's regular and annual evaluation.

Best regards,

DWI, DERMABIT WATERPROOFING INDUSTRIES CO., LTD



MONZIR MUSHTAHA
Regional Manager
Central Province

إلى من يهمه الأمر

تشهد شركة صناعات المواد العازلة للماء ديرمابيت المحدودة شركة سعودية 100% ومنتجة لأنظمة العزل المائي البيتومينية بأن شركة خليج الخرسانة ومقرها الرياض هي متخصصة ومعتمدة في مجال تركيب أنظمة العزل المائي التي تنتجها شركة ديرمابيت لفترة طويلة ولديها خبرة جيدة ومناسبة لتنفيذ المشاريع داخل المملكة العربية السعودية.

اعطيت هذه الشهادة بناء على طلبهم دون أدنى مسؤولية على شركة ديرمابيت فيما يتعلق بأي أضرار مترتبة على عيوب قد تنشأ عن أخطاء في تركيب المنتجات وخلافه.

صلاحية هذه الشهادة لمدة عام واحد من تاريخه وتخضع للتقييم السنوي المعتاد.



المكتب الرئيسي : ص.ب ١٠٣٠٨ مدينة الجبيل الصناعية ٣١٩٦١ المنطقة العربية السعودية تلفون : ٣٤١٠٤٦٤ (٠١٣) فاكس : ٣٤١٠٤٨١ (٠١٣) س.ت : ٢٠٥٥٠١٠٢٤
HEAD OFFICE : P. O. BOX 10308, JUBAIL INDUSTRIAL CITY 31961 SAUDI ARABIA TEL.: (013) 3410464 FAX : (013) 3410481 C.R.: 2055001024

CERTIFICATION

Arabian Waterproofing Industries Co. (A Saudi Joint Stock Co.)
شركة صناعات العزل العربية (شركة مساهمة سعودية)



شهادة مركب معتمد

Date : 13/03/2019

التاريخ : 13/03/2019 م

* CERTIFICATE *

* شهادة *

ARABIAN WATERPROOFING INDUSTRIES CO.

شركة صناعات العزل العربية

AWAZEL

عوازل

CERTIFIES THAT :

تشهد بأن :

GULF CRETE LTD.
For Construction, Maintenance Restoration Works
C.R 1010419075

شركة خليج الخرسانة
للإنشاءات والصيانة
ميدان تجاري / 1010419075

P.O.BOX 285893 Riyadh 11323

ص. ب 285893 الرياض 11323

Tel: 011-4655034 Fax: 011- 2939553

هاتف / 4655034-011 فاكس / 2939553-011

Is an approved applicator of our products and systems in the following fields: -

مقاول معتمد تركيب مواد وأنظمة شركتنا في مجالات العمل التالية :-

- External Waterproofing systems for underground structures including basements, tunnels, underground water tanks and swimming pools.
- Waterproofing systems for concrete roofs of public buildings and private villas.
- Waterproofing systems for metal decks of factories, warehouses and others.
- Waterproofing systems for bathrooms, kitchens and terraces.
- Joint Sealing works.
- Protective coating systems for foundations.

- ** العزل المائي للإنشاءات تحت الأرض وتشمل الأقبية والأفانق والخزانات الأرضية والمساح من الخارج.
- ** العزل المائي للأسطح الخرسانية للمباني العامة والفيلات.
- ** العزل المائي للأسطح المعدنية للمصانع والمستودعات وغيرها.
- ** العزل المائي لدورات المياه والمطابخ والبلكونات.
- ** معالجة وملء فواصل التمدد.
- ** الدهانات الواقية للأساسات.

* اعطيت هذه الشهادة بناء على طلب العميل دون أدنى مسؤولية على الشركة *

Arabian Waterproofing Industries Co.

شركة صناعات العزل العربية

AWAZEL

عوازل

Eng. Osama Al Bani



د. أوسامة الباني

شركة صناعات العزل العربية - صنع الرياض : ص.ب ١١٤٦١ المنطقة العربية السعودية - صنع الرياض : ص.ب ١١٤٦١ - ٤٦٤٥٩٨٨ تلفون : ٤٦٤٥٩٨٨ (٠١١) فاكس : ٤٦٣٤١٠٠ (٠١١) س.ت : ٢٠٥٥٠١٠٢٤
A Saudi Joint Stock Co. Capital SR. 272,969,780 P.O. Box 2965 Riyadh 11461 KSA-Email: info@awazel.com Riyadh Factory Tel. 4981904 Fax 4981707 Jeddah Factory Tel. 6374244 Fax 6367527 - C.R. 39627 C.C. 8317
Sales Marketing Offices Riyadh Tel. 4762876 Fax 4761078 Jeddah Tel. 6637460 Fax 6636989 Dammam Tel. 6341653 Fax 6330252 Doha Tel. 3380600 Fax 3360996 Kuwait Tel. 35712223 Fax 25749228 Qatar Tel. 44405371 Fax 44413104
Website: www.awazel.com

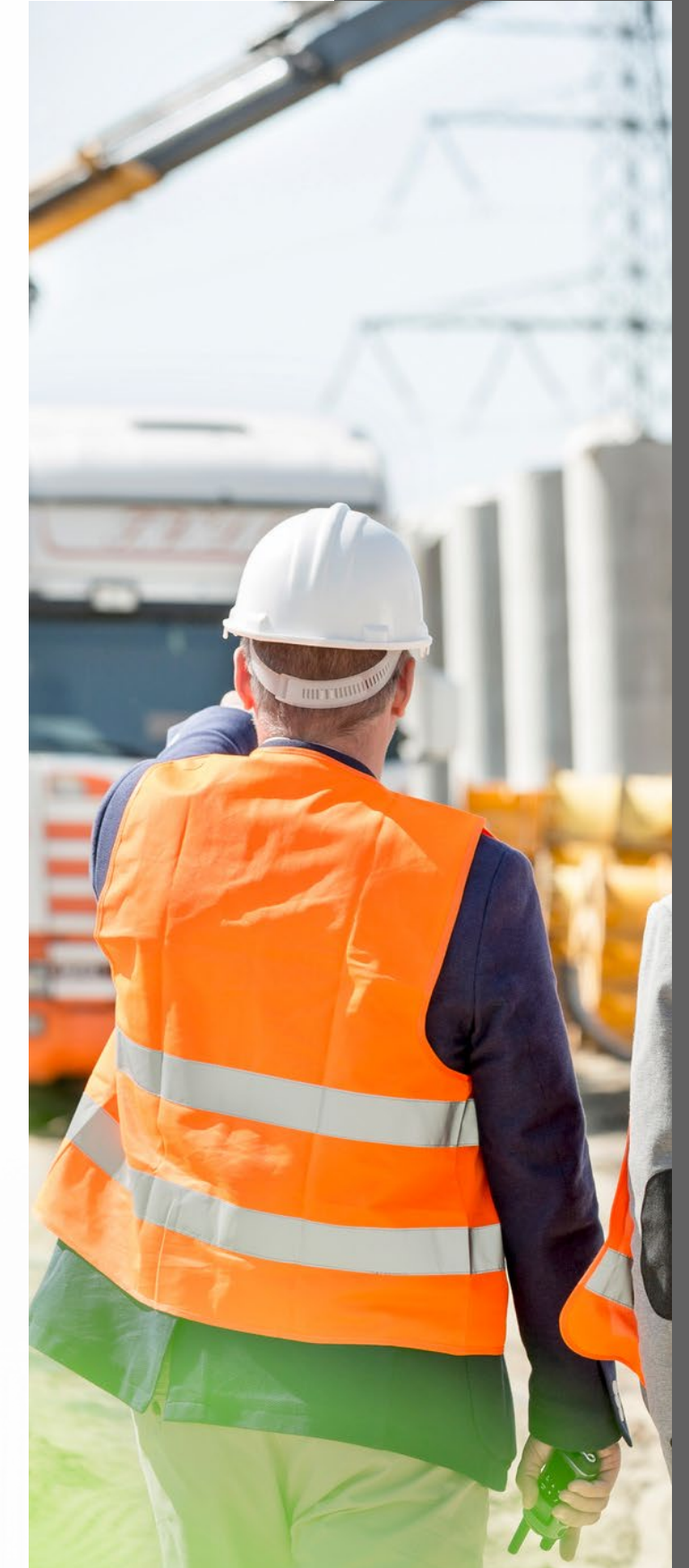

Consultant Strategic Construction Program	Client Kafuhabl Arabi	Contractor Sharqawi EIM Qofuf Al Jazeera
PROJECT NO: PROJECT NAME	LOCATION: RIYADH- KSA KSUEH- BUILDING 04	
MATERIALS SUBMITTAL		
<input checked="" type="checkbox"/> IN SUBMITTAL	SUBMITTAL NO: KSUEH45-AR-0010	PREV. SUBMITTAL NO:
<input type="checkbox"/> SUBMITTAL	DATE: 19 Feb-17	PREV. SUB AL DATE:
Submital reason	<input type="checkbox"/> INFO	<input type="checkbox"/> NOTES
Major	<input checked="" type="checkbox"/> APPROVAL	
<input type="checkbox"/> CV	<input checked="" type="checkbox"/> AR	<input type="checkbox"/> ST
<input type="checkbox"/> AC	<input type="checkbox"/> EL	<input type="checkbox"/> PL
<input type="checkbox"/> OTHER		
Attachments	<input checked="" type="checkbox"/> Brochure	
	<input checked="" type="checkbox"/> Tech. Info	
	<input type="checkbox"/> Sample	
	<input checked="" type="checkbox"/> Certificate	
	<input type="checkbox"/> Drawing	
	<input type="checkbox"/> Calculations	
Materials/Tools		
Serial	Material Name, Number & Description	Source
1	Concrete Repairs	Local
2	Protective Coating (Epoxy)	
3	Fire Proofing	
4	Water Proofing	
		Supplier / Manufacturer
		Gulf Crete LTD.
		Specs. Ref
		Code Status
CONTRACTOR		
Procurement Manager	Project Manager	
Name:	Name: Aymen Shaban	
Signature:	Site Engr. Muhaned Zyadeh	
Signature:	Signature:	
CONSULTANT NOTES		
*Accepted as a subcontractor and to be provide complete information and materials details and data sheet for review and approval.		
*Provide warranty certificate as per project specs and contract.		
CONSULTANT		
Name: Avazag Najjar	STRATEGIC CONSTRUCTION PROGRAM	
Position: Arch	Date:	
Signature:	Signature:	
Date: 2/12/2017	ENG. KHALID FAHD AL-SHAIDDI	
	General Manager of Strategic Construction Program	
APPROVAL SITUATION		
<input checked="" type="checkbox"/> APPROVED	<input type="checkbox"/> REJECTED	
<input type="checkbox"/> APP. WITH COMMENTS	<input type="checkbox"/> NO ACTION	
<input type="checkbox"/> APP. AS NOTED / RESUBMITTAL REQUIRED		
INCOMING	SIGNATURE:	OUTGOING
DATE:	DATE:	DATE:
Consultant: Original Contractor: Copy with Stamp Consultant Site Office: Copy (Authority to proceed with work does not relieve the contractor from contractual responsibilities)		



شركة الشرق للإنشاءات - ويفرز المحدودة - شركة مسودة للمباني - رأس المال 100 مليون ريال سعودي

Oriant Construction Company Ltd. **WEAVERS** - 100% OF CAPITAL IS SAUDI OWNED

الخرج
17/06/15

الى من يهمه الامر

بهذا تشهد شركة الشرق للإنشاءات- ويفرز المحدودة بأن شركة خليج الخرسانة قد قامت بتنفيذ مشروع " اعمال العزل المائي لمشروع CPP3 المراعي بمدينة الخرج كما يشهد المجلس بأن شركة خليج الخرسانة قد أوفت بكافة التزاماتها. وقد أعطيت هذه الشهادة لشركة خليج الخرسانة كشهادة انجاز لأعمال المشروع بنجاح.

شركة الشرق للإنشاءات و يفرز المحدودة

شركة الشرق للإنشاءات و يفرز المحدودة

RIYADH : C.R. 1018025339 - P.O.Box 41384 - Tel: 4760571 الرياض برت 11112 - صرب 11248 - هاتفنا ٤٧٦٠٥٧١
JEDDAH : C.R. 4030042887 JCC : 19756 - P.O.Box 11163 Jeddah 21463 جدة ٢١٤٦٣ - صرب ١١١٦٣ - هاتفنا ٤٧٦٠٥٧١
Telf: 051 774145, 053 2852 - Teler: 095814 WEAVER SA - Fax: 051 2884 هاتفنا ٥١٧٧١٤ / ٥٣٢٨٥٢ و ٥١٢٨٨٤ - فاكس: ٥١٧٧١٤







SUBCONTRACTOR PREQUALIFICATION SUBMITTAL FORM

Submittal Ref.	KSP-FHJ-INW-CMT-CIV-PQD-0140	Revision	01	Date	14-Marc-2022
Program	King Salman Park				
Project	CP03 Infrastructure Works Phase 1 & O&M Center	Project No.	CP03		
Client	King Salman Park Foundation (KSPF)				
PMO	Saudi Arabian Parsons Ltd. (SAPL)	Contractor	Freyssinet-Haif JV (FHJ)		
PMC	Faithful Gould (FGS)	PMCM			

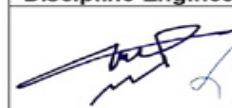
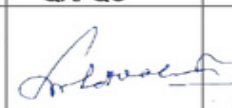





Discipline	<input checked="" type="checkbox"/> Civil	<input type="checkbox"/> Architecture	<input type="checkbox"/> Mechanical	<input type="checkbox"/> Electrical	<input type="checkbox"/> Information Technology
	<input type="checkbox"/> Landscape	<input type="checkbox"/> Others: C			

Sub-Contractor / Supplier Details	Attachments	P / x
Name: GULF CERTE – Riyadh (APPLICATOR)	Chamber of Commerce Membership.	Y
Trade: All type of Water Proofing & Thermal Insulation (APPLICATOR)	Municipality License	Y
Location: Riyadh KSA	Other Licenses (Specify):	Y
Experience (Total No. of Years): 30 Years	Please refer to PQD documents.	
Experience in KSA: 30 Years		
Contact Name: GULF CERTE Head Office Riyadh Mobile Number: 966 599281826 (Shah Rukh Ali Hassan)		
Is the company certified against any quality standard? Yes	Pre-Qualification Doc's (Specify):	Y
Is the company certified against any Health & Safety and Environment standard? Yes	Please refer to PQD documents.	
Subcontractors / Supplier's Proposed Scope of Work in this project		
- Waterproofing & Damp proofing – EPDM – TPO- FPO – POLYUREA - Spray Polyurethane foam Waterproofing - Geosynthetic Engineering - Concrete Repair and Protection – injection work - Building Renovations - Expansion joint – fire proof – decorative and protective epoxy coating - Stamped Concrete - Light Weight Foam Concrete		
	Completion Certificates for Previous Projects	Y

Contractor Signatures & Stamp			
Discipline Engineer	QA/ QC	HSE	Construction Manager
			
			

Submittal Status:	<input checked="" type="checkbox"/> A - Approved	<input type="checkbox"/> B - Approved as Noted	<input type="checkbox"/> C - Revise and Resubmit	<input type="checkbox"/> D - Rejected
Engineer's Comments:	Complied our previous comments, contractor to keep all the documentation updated.			

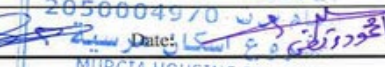
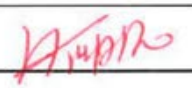
PMO/Client' Comments:	
Name	Signature
	Date

							
Client : National Housing Company		PMC : Dar al-handasah		Consultant : Khatib & Alami		General Contractor : Tamimi Global Company Ltd.	
SUPPLIER PRE-QUALIFICATION							
AR	ME	CV	LA	Submittal No.	S	P	1 2 4 Rev. 0 0
ST	EE	QS	OT	Date : 7/13/2020	Contract Drawing No.		
To: Khatib & Alami				From: Tamimi Global Company Ltd.			
Supplier Description				Attachments			
Name: GULF CRETE LTD THE SPECIALIZED CO.				<input checked="" type="checkbox"/> Company Profile			
Telephone No.: 0114655034				<input checked="" type="checkbox"/> Valid Commercial Registration Certificate			
Address: RIYADH-KSA				<input checked="" type="checkbox"/> Valid Membership of Chamber of Commerce			
Person in Charge and His Mobile No: 599281826				<input checked="" type="checkbox"/> Valid VAT Registration Certificate			
Supplier's Qualifying Log:				<input checked="" type="checkbox"/> Valid Zakat & Tax Certificate			
Years of Experience (In Total): 20 YEARS				<input checked="" type="checkbox"/> Valid General Organization of Social Insurance			
Years of Experience In Saudi Arabia: 20 YEARS				<input checked="" type="checkbox"/> Valid Saudization Certificate			
				<input type="checkbox"/> Valid Contractor Classification Certificate			
				<input type="checkbox"/> Valid SASO Certificate			
				<input checked="" type="checkbox"/> Authorized Signatory of Responsible Person			
Material to Supply: WATERPROOFING, INSULATION, FIREPROOFING, CONCRETE REPAIRS, AND FLOOR COATINGS							
Approval of Supplier does not relieve contractor of his responsibilities under contract's terms.							
Contractor's Remarks: Hardcopy of company profil (3) , cd -softcopy (3)							
Contractor Incoming: Signature:  Date: 20/06/2020				Contractor Outgoing: Signature: _____ Date: _____			
Consultant Comments: MURCIA HOUSING PROJECT							
<p>SUPPLIER APPROVED TO PROVIDE THE ABOVE MENTIONED MATERIAL.</p> <p>MATERIAL TO BE PROVIDED AND AREA OF APPLICATION IS SUBJECT TO CONSULTANT APPROVAL.</p> <p>ANY MISSING CERTIFICATE, OR OUTDATED CERTIFICATE TO BE PROVIDED</p>							
For K&A : Signature:  Date: 14/7/20							
ACTION CODE: A = Approved <input type="checkbox"/> C = Resubmit as Noted <input type="checkbox"/> B = Approved as noted <input checked="" type="checkbox"/> D = Disapproved <input type="checkbox"/>							
NOTE: The Client - National Housing Company (NHC) has the authority to approve/disapprove the supplier without any objection from its sides.							





مستشفى الملك فيصل التخصصي ومركز الأبحاث
King Faisal Specialist Hospital & Research Centre
Gen. Org. مؤسسة عامة
FACILITY PROJECTS MANAGEMENT DIVISION
PROJECTS SUPERVISION DEPARTMENT
MBC=38 Fax No. 442-7681 Tel No. 442-7661



Address: P.O.Box 92505, Riyadh City 11663 Saudi Arabia
Contractor: Equipment & Technical Services Co. (ETECHS)

Submittal Revision

TO: KING FAISAL SPECIALIST HOSPITAL & RESEARCH CENTER		FROM: Equipment & Technical Services Co. (ETECHS)		
PROJECT TITLE: REPLACEMENT-UPGRADING OF FIRE PROTECTION SYSTEM IN OFFICE AND RESIDENTIAL BUILDINGS		REF.# Contract # C/0060/40 End of Contract		
Submittal No.:SBMT-C/0060/40-0135		Rev # : 0		Submitted Date: 27-Apr-2022
Type of Submittal : <input type="checkbox"/> Drawing <input type="checkbox"/> Materials <input type="checkbox"/> Samples <input type="checkbox"/> Catalogue <input type="checkbox"/> Mock-up <input type="checkbox"/> Others				
Prequalification				
Trade: <input type="checkbox"/> Arch't <input type="checkbox"/> I.D. <input type="checkbox"/> Str/Cvl <input type="checkbox"/> Elect'rl. <input type="checkbox"/> Mech. <input type="checkbox"/> Safety				
SUBJECT: THERMAL & MOISTURE PROTECTION APPLICATOR				
ITEM No.	DESCRIPTION OF ITEM	TRADE	REVIEWER'S REMARKS	ACTION CODE
1	GULF CRETE LTD.	Arch, Str. Civil	The proposed supplier/applicator is approved with the following requirements: 1.) The supplier shall provide a 10-year warranty attested by the Chamber of Commerce for all completed works. 2.) The supplier's representatives shall be available during the warranty period in case of any defects/water leaks from the completed works. A/C:B	B
CONTRACTOR'S REMARKS FIELD: BOQ Part- 02 DIV.07 THERMAL & MOISTURE PROTECTION Item no.1		WE CERTIFY THAT THE ABOVE SUBMITTED ITEMS HAVE BEEN REVIEWED IN DETAILS & ARE IN CONFORMANCE WITH THE INTENT OF CONTRACT, DRAWING & SPECIFICATION EXCEPT AS OTHERWISE CLEARLY STATED ON CONTRACTOR'S REMARKS FIELD. Mohamed Eldosoky Contractor, Project Manager		
ACTION CODE LEGEND:				
A. Approved as submitted		D. Not approved (Work shall not proceed)		
B. Approved as noted. (Work may proceed, resubmission not required)		E. Others. (Specify)		
C. Approved as noted. (Work may proceed, resubmission required)				
REVIEWED BY: (PRSD Staff)				

Submittal of Documents or Materials for Approval on

Page 1 of 2
KFSH-PRSD

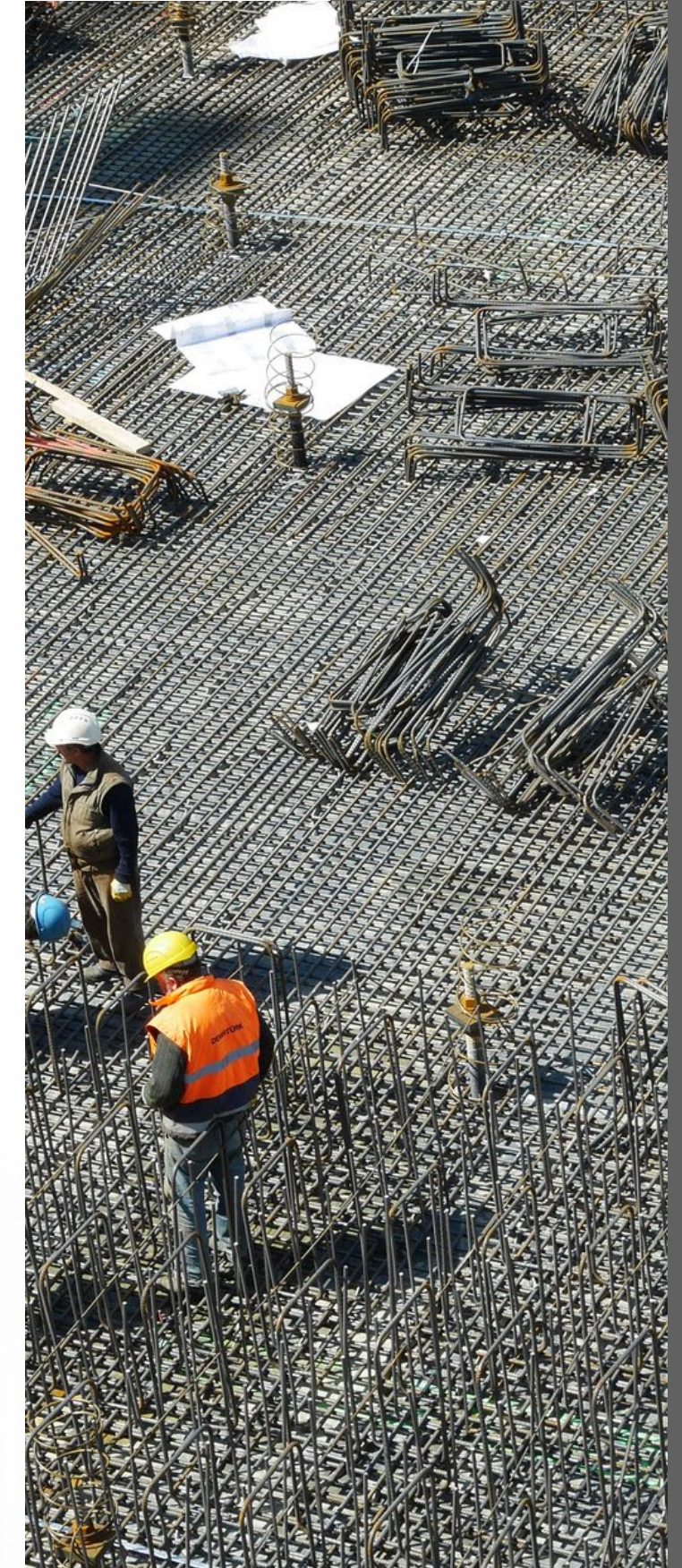



مستشفى الملك فيصل التخصصي ومركز الأبحاث
King Faisal Specialist Hospital & Research Centre
Gen. Org. مؤسسة عامة
FACILITY PROJECTS MANAGEMENT DIVISION
PROJECTS SUPERVISION DEPARTMENT
MBC=38 Fax No. 442-7681 Tel No. 442-7661



Address: P.O.Box 92505, Riyadh City 11663 Saudi Arabia
Contractor: Equipment & Technical Services Co. (ETECHS)

/	/	
Architect/Date	Mechanical Engr. /Date	Project Manager
/	/	
Interior/Date	Electrical Engr. / Date	PM Comment
/	/	
Structural Engr. / Date	Safety Officer / Date	Decision date

Submittal of Documents or Materials for Approval on

Page 2 of 2
KFSH-PRSD

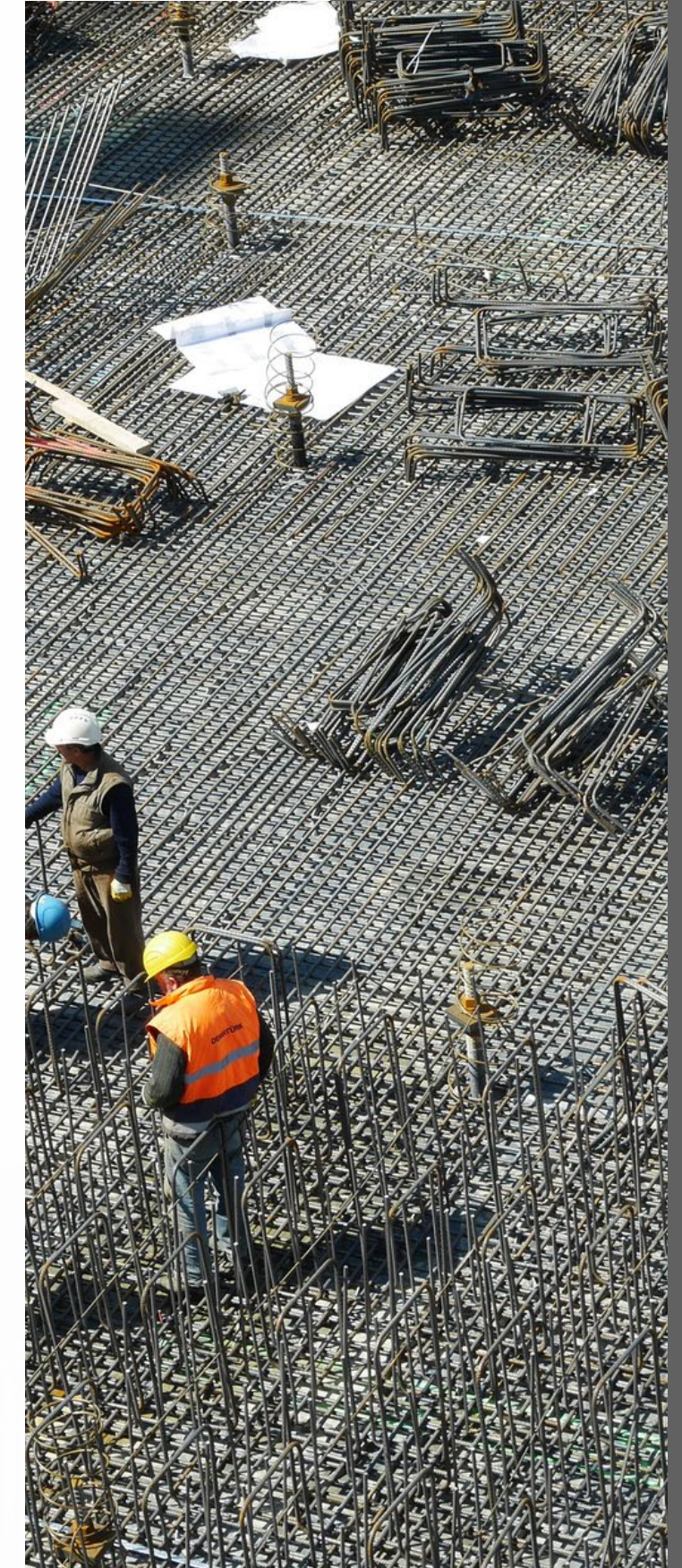

Date and Time Information

Date & Time of Print: 09/08/2021 14:08:21 – Time Zone: Arabia Time

Organisation Details

Organisation Name (English input will be accepted only)	Gulf Crete Ltd
Trade Market Name (English input will be accepted only)	Construction, Maintenance
Address	Riyadh
Country	SAUDI ARABIA
Region	منطقة الرياض / Riyadh
ZIP/Postal Code	11323
Main Organisation Phone Number	0114655034
Organisation Fax Number	0112939553
Organisation Email Address	gulfcrite@outlook.com
Web site	www.gulfcrite.com

Organisation Legal Structure

Private Limited or Limited Liability Company (شركة ذات مسؤولية محدودة)

Company Registration Number	1010419075
VAT Number	301099174300003

User Details

Title	Mr.
First Name	
Last Name	
Telephone	0114655034
Mobile	+966599281826
Email	shahrukh@gulfcrite.com
Username	shahrukh@gulfcrite.com
Preferred Language	English (UK)
Time Zone	(GMT + 3:00) Kuwait, Riyadh, Doha, Manama

Contact List

Last Name	First Name	Email	Phone Number
1		shahrukh@gulfcrite.com	0114655034

Registration Date

30/06/2020

List of Forms

No Forms found

Path	Category Title	Last Modification Date	Status Summary	Assessments Present
1	Status Completed MAINTENANCE AND REPAIR FACILITY	11/01/2021	Assessment Status not visible	0
2	Status Completed ADHESIVE AND SEALANTS	11/01/2021	Assessment Status not visible	1
3	Status Completed INTERIOR FINISHING	11/01/2021	Assessment Status not visible	1
4	Status Completed OPERATION AND MAINTINANCE	11/01/2021	Assessment Status not visible	1
5	Status Completed FIRE FIGHTING SYSTEMS	11/01/2021	Assessment Status not visible	1
6	Status Completed CARGO HANDLING FACILITIES	11/01/2021	Assessment Status not visible	1
7	Status Completed TERMINAL	11/01/2021	Assessment Status not visible	1
8	Status Completed CAR PARKING	11/01/2021	Assessment Status not visible	1
9	Status Completed CIVIL WORKS	11/01/2021	Assessment Status not visible	1
10	Status Completed ROOFING MATERIALS	01/07/2020	Assessment Status not visible	1
11	Status Completed PAINTS & COATING SUPPLIES	01/07/2020	Assessment Status not visible	1
12	Status Completed METAL/STEEL STRUCTURE	01/07/2020	Assessment Status not visible	1

Path	Title	Date	Status Summary	Present
13	Status Completed AIRPORTS CONTRACTING	01/07/2020	Assessment Status not visible	1
14	Status Completed MAIN,MINOR SEWERAGE, NETWORK	11/01/2021	Assessment Status not visible	1
15	Status Completed CAR PARKING,OTHER SHADES STRCT	01/07/2020	Assessment Status not visible	1
16	Status Completed HANGERS,WAREHOUSE WORKS	01/07/2020	Assessment Status not visible	1
17	Status Completed MAIN ROADS,STREETS RELATED WRK	11/01/2021	Assessment Status not visible	1
18	Status Completed COOLANT AND ADDITIVES	01/07/2020	Assessment Status not visible	1
19	Status Completed ADHESIVE AND SEALANTS	01/07/2020	Assessment Status not visible	1
20	Status Completed INFRASTRUCTURE,BUILDING WORKS	01/07/2020	Assessment Status not visible	1
21	Status Completed GEOPHYSICAL	11/01/2021	Assessment Status not visible	1
22	Status Completed CAR PARKING SYSTEM	01/07/2020	Assessment Status not visible	1
23	Status Completed JOINTING,PACKING	11/01/2021	Assessment Status not visible	1
24	Status Completed VESSELS AND TANKS	01/07/2020	Assessment Status not visible	1
25	Status Completed DIGGING AND PILING WORKS	11/01/2021	Assessment Status not visible	1
26	Status Completed RESIDENT ENGINEERING SERVICES	11/01/2021	Assessment Status not visible	1
27	Status Completed MASONRY,STONE WORK TILE	01/07/2020	Assessment Status not visible	1
28	Status Completed MAINTENANCE SERVICES	11/01/2021	Assessment Status not visible	1
29	Status Completed MATERIALS	01/07/2020	Assessment Status not visible	1
30	Status Completed CLADDING WORKS	01/07/2020	Assessment Status not visible	1
31	Status Completed FORWARDING FACILITY	11/01/2021	Assessment Status not visible	1
32	Status Completed GENERAL WORKS	01/07/2020	Assessment Status not visible	1
33	Status Completed INDUSTRIAL WORKS	01/07/2020	Assessment Status not visible	1
34	Status Completed ROAD MARKINGS	01/07/2020	Assessment Status not visible	1
35	Status Completed EXTERIOR RENOVATION WORKS	11/01/2021	Assessment Status not visible	1
36	Status Completed INTERIOR RENOVATION WORKS	11/01/2021	Assessment Status not visible	1
37	Status Completed FIRE SUPPRESSION SYSTEMS	11/01/2021	Assessment Status not visible	1
38	Status Completed CARPET AND FLOORING	11/01/2021	Assessment Status not visible	1
39	Status Completed TOPOGRAPHIC & OTHER	11/01/2021	Assessment Status not visible	1
40	Status Completed PAINT	01/07/2020	Assessment Status not visible	0
41	Status Completed SEALANT	11/01/2021	Assessment Status not visible	0
42	Status Completed SEALER	11/01/2021	Assessment Status not visible	0
43	Status Completed SEAL	11/01/2021	Assessment Status not visible	0
44	Status Completed JOINT	11/01/2021	Assessment Status not visible	0
45	Status Completed INSULATION	01/07/2020	Assessment Status not visible	0

No Segmentation Assessment found

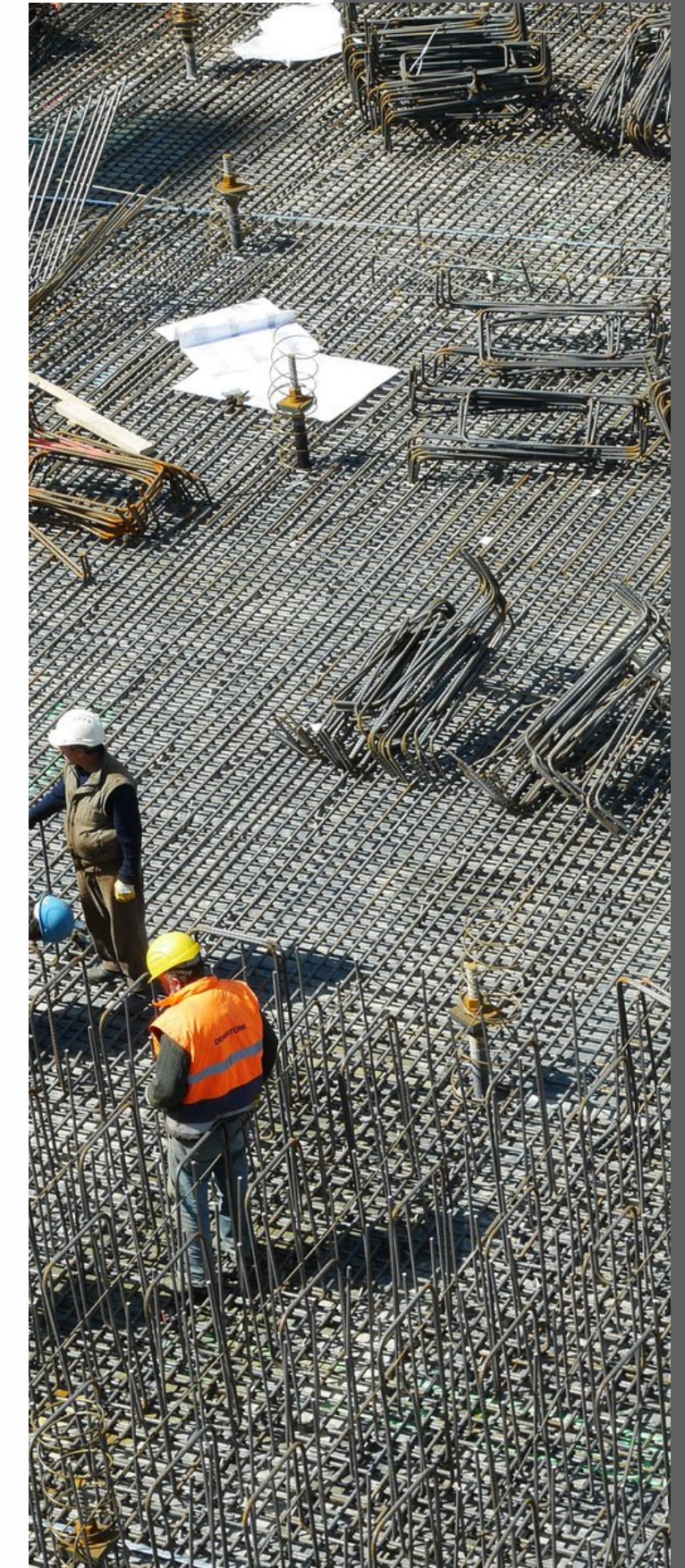

Date and Time Information

Date & Time of Print: 09/08/2021 14:08:21 – Time Zone: Arabia Time

Organisation Details

Organisation Name (English input will be accepted only)	Gulf Crete Ltd
Trade Market Name (English input will be accepted only)	Construction, Maintenance
Address	Riyadh
Country	SAUDI ARABIA
Region	منطقة الرياض / Riyadh
ZIP/Postal Code	11323
Main Organisation Phone Number	0114655034
Organisation Fax Number	0112939553
Organisation Email Address	gulfcrete@outlook.com
Web site	www.gulfcrete.com

Organisation Legal Structure

Private Limited or Limited Liability Company (شركة ذات مسؤولية محدودة)

Company Registration Number	1010419075
VAT Number	301099174300003

User Details

Title	Mr.
First Name	
Last Name	
Telephone	0114655034
Mobile	+966599281826
Email	shahrukh@gulfcrete.com
Username	shahrukh@gulfcrete.com
Preferred Language	English (UK)
Time Zone	(GMT + 3:00) Kuwait, Riyadh, Doha, Manama

Contact List

Last Name	First Name	Email	Phone Number
1		shahrukh@gulfcrete.com	0114655034

Registration Date

30/06/2020

List of Forms

No Forms found

Path	Category Title	Last Modification Date	Status Summary	Assessments Present
1	Status Completed MAINTENANCE AND REPAIR FACILITY	11/01/2021	Assessment Status not visible	0
2	Status Completed ADHESIVE AND SEALANTS	11/01/2021	Assessment Status not visible	1
3	Status Completed INTERIOR FINISHING	11/01/2021	Assessment Status not visible	1
4	Status Completed OPERATION AND MAINTINANCE	11/01/2021	Assessment Status not visible	1
5	Status Completed FIRE FIGHTING SYSTEMS	11/01/2021	Assessment Status not visible	1
6	Status Completed CARGO HANDLING FACILITIES	11/01/2021	Assessment Status not visible	1
7	Status Completed TERMINAL	11/01/2021	Assessment Status not visible	1
8	Status Completed CAR PARKING	11/01/2021	Assessment Status not visible	1
9	Status Completed CIVIL WORKS	11/01/2021	Assessment Status not visible	1
10	Status Completed ROOFING MATERIALS	01/07/2020	Assessment Status not visible	1
11	Status Completed PAINTS & COATING SUPPLIES	01/07/2020	Assessment Status not visible	1
12	Status Completed METAL/STEEL STRUCTURE	01/07/2020	Assessment Status not visible	1

Path	Title	Date	Status Summary	Present
13	Status Completed AIRPORTS CONTRACTING	01/07/2020	Assessment Status not visible	1
14	Status Completed MAIN,MINOR SEWERAGE, NETWORK	11/01/2021	Assessment Status not visible	1
15	Status Completed CAR PARKING,OTHER SHADES STRCT	01/07/2020	Assessment Status not visible	1
16	Status Completed HANGERS,WAREHOUSE WORKS	01/07/2020	Assessment Status not visible	1
17	Status Completed MAIN ROADS,STREETS RELATED WRK	11/01/2021	Assessment Status not visible	1
18	Status Completed COOLANT AND ADDITIVES	01/07/2020	Assessment Status not visible	1
19	Status Completed ADHESIVE AND SEALANTS	01/07/2020	Assessment Status not visible	1
20	Status Completed INFRASTRUCTURE,BUILDING WORKS	01/07/2020	Assessment Status not visible	1
21	Status Completed GEOPHYSICAL	11/01/2021	Assessment Status not visible	1
22	Status Completed CAR PARKING SYSTEM	01/07/2020	Assessment Status not visible	1
23	Status Completed JOINTING,PACKING	11/01/2021	Assessment Status not visible	1
24	Status Completed VESSELS AND TANKS	01/07/2020	Assessment Status not visible	1
25	Status Completed DIGGING AND PILING WORKS	11/01/2021	Assessment Status not visible	1
26	Status Completed RESIDENT ENGINEERING SERVICES	11/01/2021	Assessment Status not visible	1
27	Status Completed MASONRY,STONE WORK TILE	01/07/2020	Assessment Status not visible	1
28	Status Completed MAINTENANCE SERVICES	11/01/2021	Assessment Status not visible	1
29	Status Completed MATERIALS	01/07/2020	Assessment Status not visible	1
30	Status Completed CLADDING WORKS	01/07/2020	Assessment Status not visible	1
31	Status Completed FORWARDING FACILITY	11/01/2021	Assessment Status not visible	1
32	Status Completed GENERAL WORKS	01/07/2020	Assessment Status not visible	1
33	Status Completed INDUSTRIAL WORKS	01/07/2020	Assessment Status not visible	1
34	Status Completed ROAD MARKINGS	01/07/2020	Assessment Status not visible	1
35	Status Completed EXTERIOR RENOVATION WORKS	11/01/2021	Assessment Status not visible	1
36	Status Completed INTERIOR RENOVATION WORKS	11/01/2021	Assessment Status not visible	1
37	Status Completed FIRE SUPPRESSION SYSTEMS	11/01/2021	Assessment Status not visible	1
38	Status Completed CARPET AND FLOORING	11/01/2021	Assessment Status not visible	1
39	Status Completed TOPOGRAPHIC & OTHER	11/01/2021	Assessment Status not visible	1
40	Status Completed PAINT	01/07/2020	Assessment Status not visible	0
41	Status Completed SEALANT	11/01/2021	Assessment Status not visible	0
42	Status Completed SEALER	11/01/2021	Assessment Status not visible	0
43	Status Completed SEAL	11/01/2021	Assessment Status not visible	0
44	Status Completed JOINT	11/01/2021	Assessment Status not visible	0
45	Status Completed INSULATION	01/07/2020	Assessment Status not visible	0

No Segmentation Assessment found

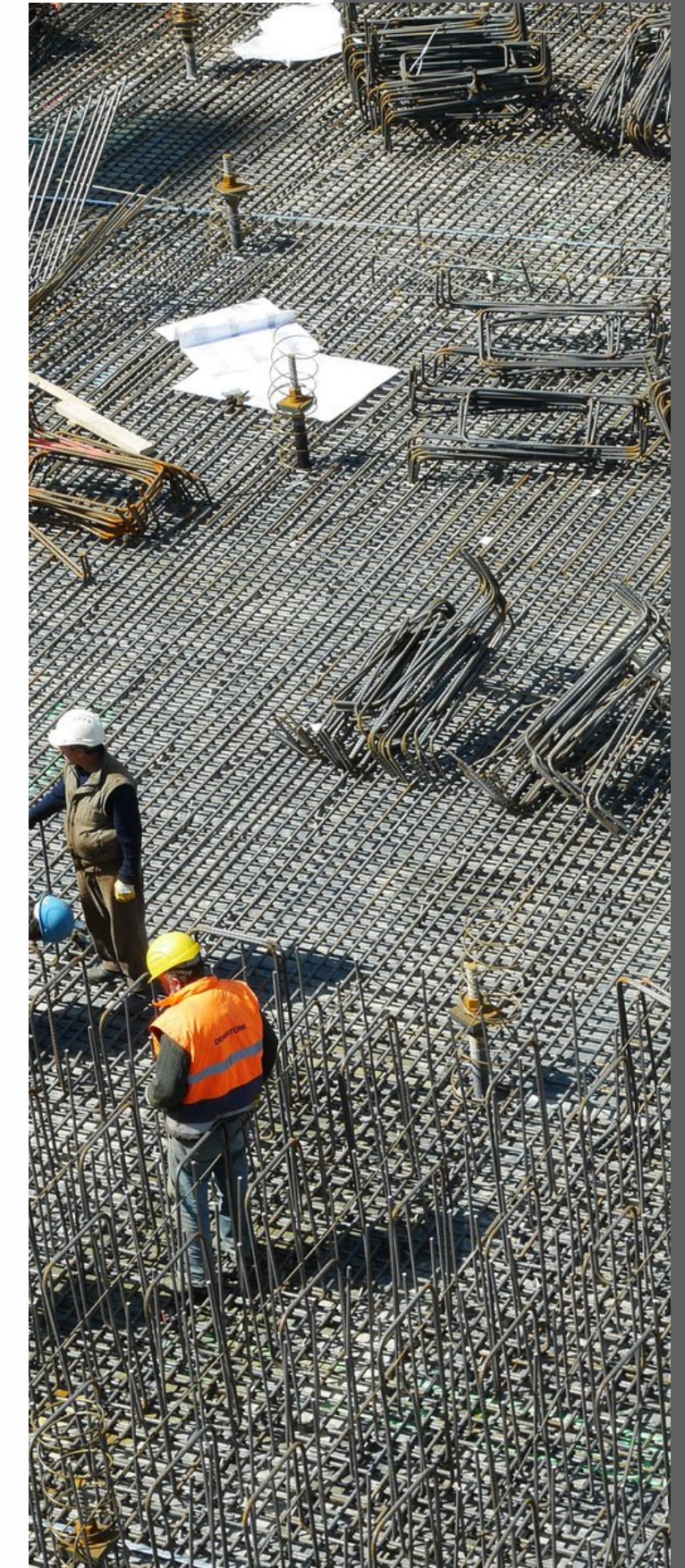

CERTIFICATION

Consultant Strategic Construction Program		Client Innovative Labs		Contractor Sharqawi E/M Qituf Al Jazeera	
PROJECT NO:			LOCATION: RIYADH- KSA		
PROJECT NAME: KSUEH- BUILDING 04					
MATERIALS SUBMITTAL					
<input checked="" type="checkbox"/> SUBMITTAL		SUBMITTAL NO: KSUEH-04-AR-0015		PREV. SUBMITTAL NO:	
<input type="checkbox"/> SUBMITTAL		DATE: 19 Feb-17		PREV. SUB. AL DATE:	
Submittal reason		<input type="checkbox"/> INFO		<input type="checkbox"/> NOTES	
Major		<input type="checkbox"/> CV		<input type="checkbox"/> AR	
		<input type="checkbox"/> ST		<input type="checkbox"/> AC	
		<input type="checkbox"/> EL		<input type="checkbox"/> PL	
		<input type="checkbox"/> OTHER			
Attachments					
<input type="checkbox"/> Brochure		<input type="checkbox"/> Tech. Info		<input type="checkbox"/> Sample	
<input type="checkbox"/> Materials/Tools		<input checked="" type="checkbox"/> Certificate		<input type="checkbox"/> Drawing	
<input type="checkbox"/> Calculations					
Serial	Material Name, Number & Description	Source	Supplier / Manufacturer	Specs. Ref	Code Status
1	Concrete Repairs	Local	Gulf Crete LTD.		B
2	Protective Coating (Epoxy)				
3	Fire Proofing				
4	Water Proofing				
CONTRACTOR					
Procurement Manager			Project Manager		
Name: _____			Name: Ayman Shaban		
Signature: _____			Site Engr. Muhaned Zyadeh		
Signature: _____			Signature: _____		
CONSULTANT NOTES					
*Accepted as a subcontractor and to be provide complete information and materials details and data sheet for review and approval.					
*Provide warranty certificate as per project spec and Contract.					
CONSULTANT			STRATEGIC CONSTRUCTION PROGRAM		
Name: Avazag Najjar			Date: _____		
Position: Arch			Signature: _____		
Signature: _____			ENG. KHALID FAHD AL-SHAIDDI		
Date: 2/2/2017			General Manager of Strategic Construction Program		
APPROVAL SITUATION					
<input checked="" type="checkbox"/> APPROVED		<input type="checkbox"/> REJECTED			
<input type="checkbox"/> APP WITH COMMENTS		<input type="checkbox"/> NO ACTION			
<input type="checkbox"/> APP. AS NOTED/RESUBMITTAL REQUIRED					
INCOMING	SIGNATURE:	OUTGOING:	SIGNATURE:	DATE:	DATE:
Consultant: Original		Contractor: Copy with Stamp		Consultant Site Office: Copy	
(Authority to proceed with work does not relieve the contractor from contractual responsibilities)					



CERTIFICATION

 AL-JAZEERA PAINTS

Date : 23/11/2013
Ref. # : GSM-AG-87-14

CERTIFICATION

TO WHOM SO IT MAY CONCERN :

This is to certify that **M/S. Gulf Crete Ltd Co.** Is our qualified paint Contractor / applicator in **Protective coatings & intumescent fire proof** in the kingdom of Saudi Arabia .

This certification is valid for 1 year and will be subject to review on **23/11/2015**

Furthermore, this recommendation is made by Al-Jazeera paints Co. without Prejudice / or legal liability.

Ahmed Taleb
Projects General Manager

 GULF CRETE LTD CO.

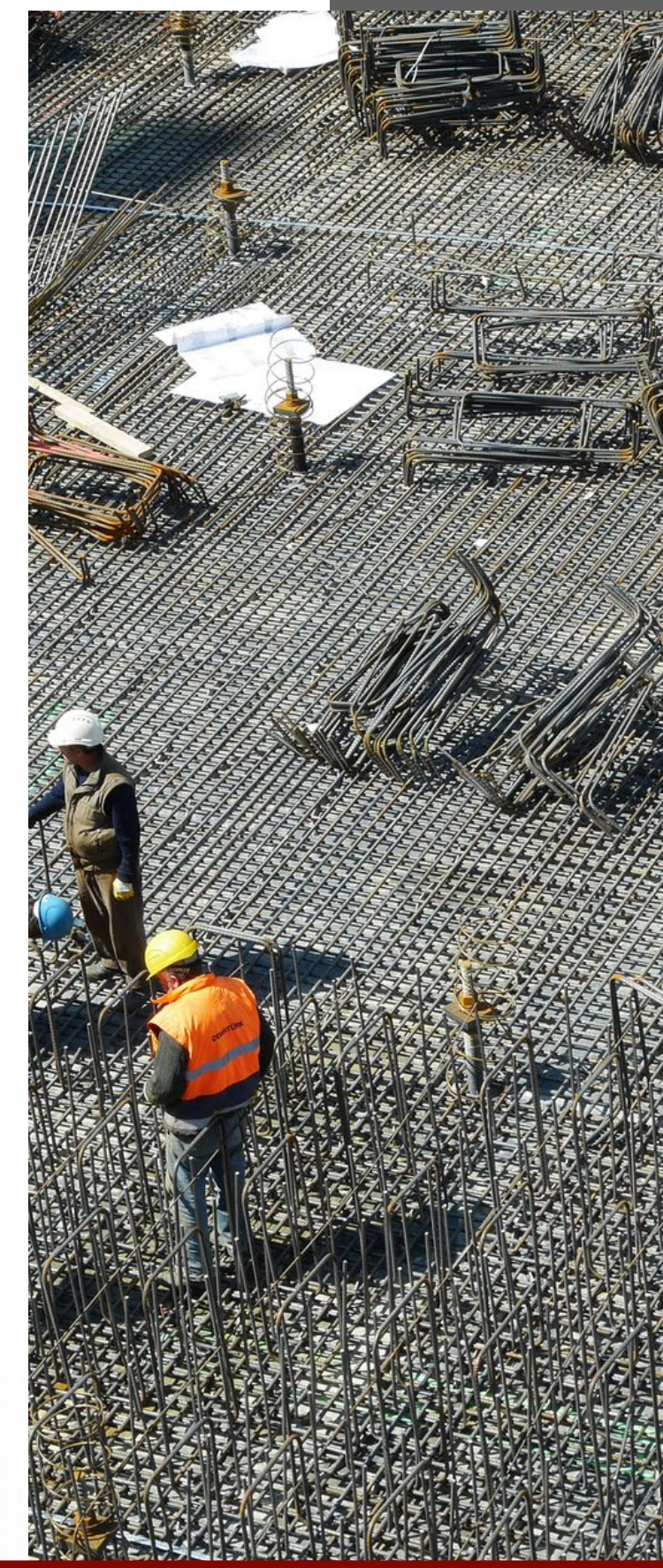

Date and Time Information

Date & Time of Print: 09/08/2021 14:08:21 – Time Zone: Arabia Time

Organisation Details

Organisation Name (English input will be accepted only)	Gulf Crete Ltd
Trade Market Name (English input will be accepted only)	Construction, Maintenance
Address	Riyadh
Country	SAUDI ARABIA
Region	منطقة الرياض / Riyadh
ZIP/Postal Code	11323
Main Organisation Phone Number	0114655034
Organisation Fax Number	0112939553
Organisation Email Address	gulfcrite@outlook.com
Web site	www.gulfcrite.com

Organisation Legal Structure

Private Limited or Limited Liability Company (شركة ذات مسؤولية محدودة)

Company Registration Number	1010419075
VAT Number	301099174300003

User Details

Title	Mr.
First Name	
Last Name	
Telephone	0114655034
Mobile	+966599281826
Email	shahrukh@gulfcrite.com
Username	shahrukh@gulfcrite.com
Preferred Language	English (UK)
Time Zone	(GMT + 3:00) Kuwait, Riyadh, Doha, Manama

Contact List

Last Name	First Name	Email	Phone Number
1		shahrukh@gulfcrite.com	0114655034

Registration Date

30/06/2020

List of Forms

No Forms found

Path	Category Title	Last Modification Date	Status Summary	Assessments Present
1	Status Completed MAINTENANCE AND REPAIR FACILITY	11/01/2021	Assessment Status not visible	0
2	Status Completed ADHESIVE AND SEALANTS	11/01/2021	Assessment Status not visible	1
3	Status Completed INTERIOR FINISHING	11/01/2021	Assessment Status not visible	1
4	Status Completed OPERATION AND MAINTINANCE	11/01/2021	Assessment Status not visible	1
5	Status Completed FIRE FIGHTING SYSTEMS	11/01/2021	Assessment Status not visible	1
6	Status Completed CARGO HANDLING FACILITIES	11/01/2021	Assessment Status not visible	1
7	Status Completed TERMINAL	11/01/2021	Assessment Status not visible	1
8	Status Completed CAR PARKING	11/01/2021	Assessment Status not visible	1
9	Status Completed CIVIL WORKS	11/01/2021	Assessment Status not visible	1
10	Status Completed ROOFING MATERIALS	01/07/2020	Assessment Status not visible	1
11	Status Completed PAINTS & COATING SUPPLIES	01/07/2020	Assessment Status not visible	1
12	Status Completed METAL/STEEL STRUCTURE	01/07/2020	Assessment Status not visible	1

Path	Title	Date	Status Summary	Present
13	Status Completed AIRPORTS CONTRACTING	01/07/2020	Assessment Status not visible	1
14	Status Completed MAIN,MINOR SEWERAGE, NETWORK	11/01/2021	Assessment Status not visible	1
15	Status Completed CAR PARKING,OTHER SHADES STRCT	01/07/2020	Assessment Status not visible	1
16	Status Completed HANGERS,WAREHOUSE WORKS	01/07/2020	Assessment Status not visible	1
17	Status Completed MAIN ROADS,STREETS RELATED WRK	11/01/2021	Assessment Status not visible	1
18	Status Completed COOLANT AND ADDITIVES	01/07/2020	Assessment Status not visible	1
19	Status Completed ADHESIVE AND SEALANTS	01/07/2020	Assessment Status not visible	1
20	Status Completed INFRASTRUCTURE,BUILDING WORKS	01/07/2020	Assessment Status not visible	1
21	Status Completed GEOPHYSICAL	11/01/2021	Assessment Status not visible	1
22	Status Completed CAR PARKING SYSTEM	01/07/2020	Assessment Status not visible	1
23	Status Completed JOINTING,PACKING	11/01/2021	Assessment Status not visible	1
24	Status Completed VESSELS AND TANKS	01/07/2020	Assessment Status not visible	1
25	Status Completed DIGGING AND PILING WORKS	11/01/2021	Assessment Status not visible	1
26	Status Completed RESIDENT ENGINEERING SERVICES	11/01/2021	Assessment Status not visible	1
27	Status Completed MASONRY,STONE WORK TILE	01/07/2020	Assessment Status not visible	1
28	Status Completed MAINTENANCE SERVICES	11/01/2021	Assessment Status not visible	1
29	Status Completed MATERIALS	01/07/2020	Assessment Status not visible	1
30	Status Completed CLADDING WORKS	01/07/2020	Assessment Status not visible	1
31	Status Completed FORWARDING FACILITY	11/01/2021	Assessment Status not visible	1
32	Status Completed GENERAL WORKS	01/07/2020	Assessment Status not visible	1
33	Status Completed INDUSTRIAL WORKS	01/07/2020	Assessment Status not visible	1
34	Status Completed ROAD MARKINGS	01/07/2020	Assessment Status not visible	1
35	Status Completed EXTERIOR RENOVATION WORKS	11/01/2021	Assessment Status not visible	1
36	Status Completed INTERIOR RENOVATION WORKS	11/01/2021	Assessment Status not visible	1
37	Status Completed FIRE SUPPRESSION SYSTEMS	11/01/2021	Assessment Status not visible	1
38	Status Completed CARPET AND FLOORING	11/01/2021	Assessment Status not visible	1
39	Status Completed TOPOGRAPHIC & OTHER	11/01/2021	Assessment Status not visible	1
40	Status Completed PAINT	01/07/2020	Assessment Status not visible	0
41	Status Completed SEALANT	11/01/2021	Assessment Status not visible	0
42	Status Completed SEALER	11/01/2021	Assessment Status not visible	0
43	Status Completed SEAL	11/01/2021	Assessment Status not visible	0
44	Status Completed JOINT	11/01/2021	Assessment Status not visible	0
45	Status Completed INSULATION	01/07/2020	Assessment Status not visible	0

No Segmentation Assessment found

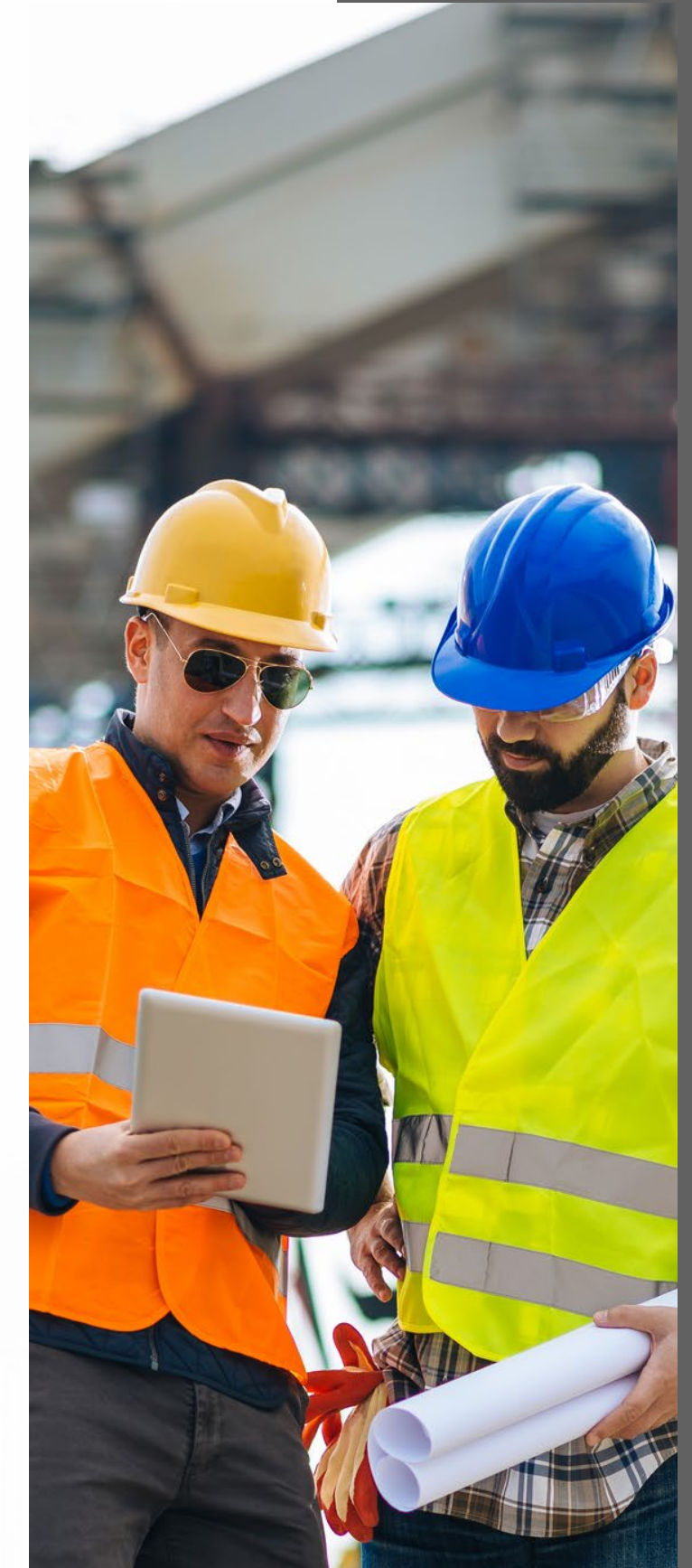

CERTIFICATE

FOR RECOMMENDED SIKA APPLICATORS

This is to certify that

GULF CRETE CONTRACTING

Has successfully executed many Projects after having passed the application training of various Sika systems and is Recommended Sika Applicator for

Concrete repair and protection, Waterproofing (PVC membranes loose laid and full compartment system), Cementitious, Resins, Combiflex range), Joint Sealants and Industrial flooring.

This comprehensive training consisted of practical instructions about proper storage, preparation and application of Sika products.

The recommended applicator has been provided with the relevant Sika Product Data Sheets and all other technical documentation.

This confirmation is valid until the date of expiry below and may be renewed subject to the Recommended Applicator successfully completing any training courses required by Sika. The Recommended Applicator is responsible for ensuring full compliance by its employees with Sika's guidelines, training instructions and any other requirements of third parties.

Sika is not responsible for any loss or damage suffered by any third party as a result of any acts or omissions of the Recommended Applicator arising in anyway, including but not limited to breach of contract, misrepresentation, failure to comply with applicable laws or any other tort including negligence.

Sika Saudi Arabia,

Issuing Date: January 01, 2016

Expiry Date: December 31, 2016

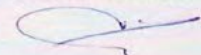

Shehadeh Salman
T.M Waterproofing Manager
Central Region
Sika Saudi Arabia

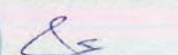
Emad Al Asqar
Sr. Sales Manager
Central Region
Sika Saudi Arabia

This Recommendation does not assume responsibility for the correct storage, mixing or use of these Products. Sika shall not be liable for damage to persons or property, loss of business or profit or any other direct, indirect, incidental, special or consequential damage or caused by the Recommended Applicator. Sika shall also not be responsible for use of these Products in a manner to infringe on any patent or other intellectual property rights held by others. Sika's liability is limited to the quality only of the supplied material. Any failures due to wrong application or storage not in accordance with the given guidelines as stated on the latest Technical Data Sheets, as well as structural or mechanical failures are excluded herein.

BUILDING TRUST



Constructive solutions

Ref : AY/06/22

Date: June 21, 2022.

TO WHOM IT MAY CONCERN

This is to certify that M/s. **Gulferete** have considered as our certified and approved applicator for following Fosam Products' Range as below:

- Concrete Repair.
- Protective Coatings.
- Industrial Flooring.
- Joint Sealants.

This certificate is issued upon their request without any liabilities on Fosam Company Limited and valid for six months from the date of issuance of this certificate.

Yours sincerely,
For Fosam Company Limited



Fosam Company Limited
Head Office
PO Box 11081
Jeddah - 21452
Saudi Arabia
C.R. No. 31273
Paid up Capital: SR3,000,000
www.fosroc.com

تلفون: +966 (0) 2 837 8328

تلفون: +966 (0) 837 8327

تيم: team@fosroc.com



Date and Time Information

Date & Time of Print: 09/08/2021 14:08:21 – Time Zone: Arabia Time

Organisation Details

Organisation Name (English input will be accepted only)	Gulf Crete Ltd
Trade Market Name (English input will be accepted only)	Construction, Maintenance
Address	Riyadh
Country	SAUDI ARABIA
Region	منطقة الرياض / Riyadh
ZIP/Postal Code	11323
Main Organisation Phone Number	0114655034
Organisation Fax Number	0112939553
Organisation Email Address	gulfcrite@outlook.com
Web site	www.gulfcrite.com

Organisation Legal Structure

Private Limited or Limited Liability Company (شركة ذات مسؤولية محدودة)

Company Registration Number	1010419075
VAT Number	301099174300003

User Details

Title	Mr.
First Name	
Last Name	
Telephone	0114655034
Mobile	+966599281826
Email	shahrukh@gulfcrite.com
Username	shahrukh@gulfcrite.com
Preferred Language	English (UK)
Time Zone	(GMT + 3:00) Kuwait, Riyadh, Doha, Manama

Contact List

Last Name	First Name	Email	Phone Number
1		shahrukh@gulfcrite.com	0114655034

Registration Date

30/06/2020

List of Forms

No Forms found

Path	Category Title	Last Modification Date	Status Summary	Assessments Present
1	Status Completed MAINTENANCE AND REPAIR FACILITY	11/01/2021	Assessment Status not visible	0
2	Status Completed ADHESIVE AND SEALANTS	11/01/2021	Assessment Status not visible	1
3	Status Completed INTERIOR FINISHING	11/01/2021	Assessment Status not visible	1
4	Status Completed OPERATION AND MAINTINANCE	11/01/2021	Assessment Status not visible	1
5	Status Completed FIRE FIGHTING SYSTEMS	11/01/2021	Assessment Status not visible	1
6	Status Completed CARGO HANDLING FACILITIES	11/01/2021	Assessment Status not visible	1
7	Status Completed TERMINAL	11/01/2021	Assessment Status not visible	1
8	Status Completed CAR PARKING	11/01/2021	Assessment Status not visible	1
9	Status Completed CIVIL WORKS	11/01/2021	Assessment Status not visible	1
10	Status Completed ROOFING MATERIALS	01/07/2020	Assessment Status not visible	1
11	Status Completed PAINTS & COATING SUPPLIES	01/07/2020	Assessment Status not visible	1
12	Status Completed METAL/STEEL STRUCTURE	01/07/2020	Assessment Status not visible	1

Path	Title	Date	Status Summary	Present
13	Status Completed AIRPORTS CONTRACTING	01/07/2020	Assessment Status not visible	1
14	Status Completed MAIN,MINOR SEWERAGE, NETWORK	11/01/2021	Assessment Status not visible	1
15	Status Completed CAR PARKING,OTHER SHADES STRCT	01/07/2020	Assessment Status not visible	1
16	Status Completed HANGERS,WAREHOUSE WORKS	01/07/2020	Assessment Status not visible	1
17	Status Completed MAIN ROADS,STREETS RELATED WRK	11/01/2021	Assessment Status not visible	1
18	Status Completed COOLANT AND ADDITIVES	01/07/2020	Assessment Status not visible	1
19	Status Completed ADHESIVE AND SEALANTS	01/07/2020	Assessment Status not visible	1
20	Status Completed INFRASTRUCTURE,BUILDING WORKS	01/07/2020	Assessment Status not visible	1
21	Status Completed GEOPHYSICAL	11/01/2021	Assessment Status not visible	1
22	Status Completed CAR PARKING SYSTEM	01/07/2020	Assessment Status not visible	1
23	Status Completed JOINTING,PACKING	11/01/2021	Assessment Status not visible	1
24	Status Completed VESSELS AND TANKS	01/07/2020	Assessment Status not visible	1
25	Status Completed DIGGING AND PILING WORKS	11/01/2021	Assessment Status not visible	1
26	Status Completed RESIDENT ENGINEERING SERVICES	11/01/2021	Assessment Status not visible	1
27	Status Completed MASONRY,STONE WORK TILE	01/07/2020	Assessment Status not visible	1
28	Status Completed MAINTENANCE SERVICES	11/01/2021	Assessment Status not visible	1
29	Status Completed MATERIALS	01/07/2020	Assessment Status not visible	1
30	Status Completed CLADDING WORKS	01/07/2020	Assessment Status not visible	1
31	Status Completed FORWARDING FACILITY	11/01/2021	Assessment Status not visible	1
32	Status Completed GENERAL WORKS	01/07/2020	Assessment Status not visible	1
33	Status Completed INDUSTRIAL WORKS	01/07/2020	Assessment Status not visible	1
34	Status Completed ROAD MARKINGS	01/07/2020	Assessment Status not visible	1
35	Status Completed EXTERIOR RENOVATION WORKS	11/01/2021	Assessment Status not visible	1
36	Status Completed INTERIOR RENOVATION WORKS	11/01/2021	Assessment Status not visible	1
37	Status Completed FIRE SUPPRESSION SYSTEMS	11/01/2021	Assessment Status not visible	1
38	Status Completed CARPET AND FLOORING	11/01/2021	Assessment Status not visible	1
39	Status Completed TOPOGRAPHIC & OTHER	11/01/2021	Assessment Status not visible	1
40	Status Completed PAINT	01/07/2020	Assessment Status not visible	0
41	Status Completed SEALANT	11/01/2021	Assessment Status not visible	0
42	Status Completed SEALER	11/01/2021	Assessment Status not visible	0
43	Status Completed SEAL	11/01/2021	Assessment Status not visible	0
44	Status Completed JOINT	11/01/2021	Assessment Status not visible	0
45	Status Completed INSULATION	01/07/2020	Assessment Status not visible	0

No Segmentation Assessment found

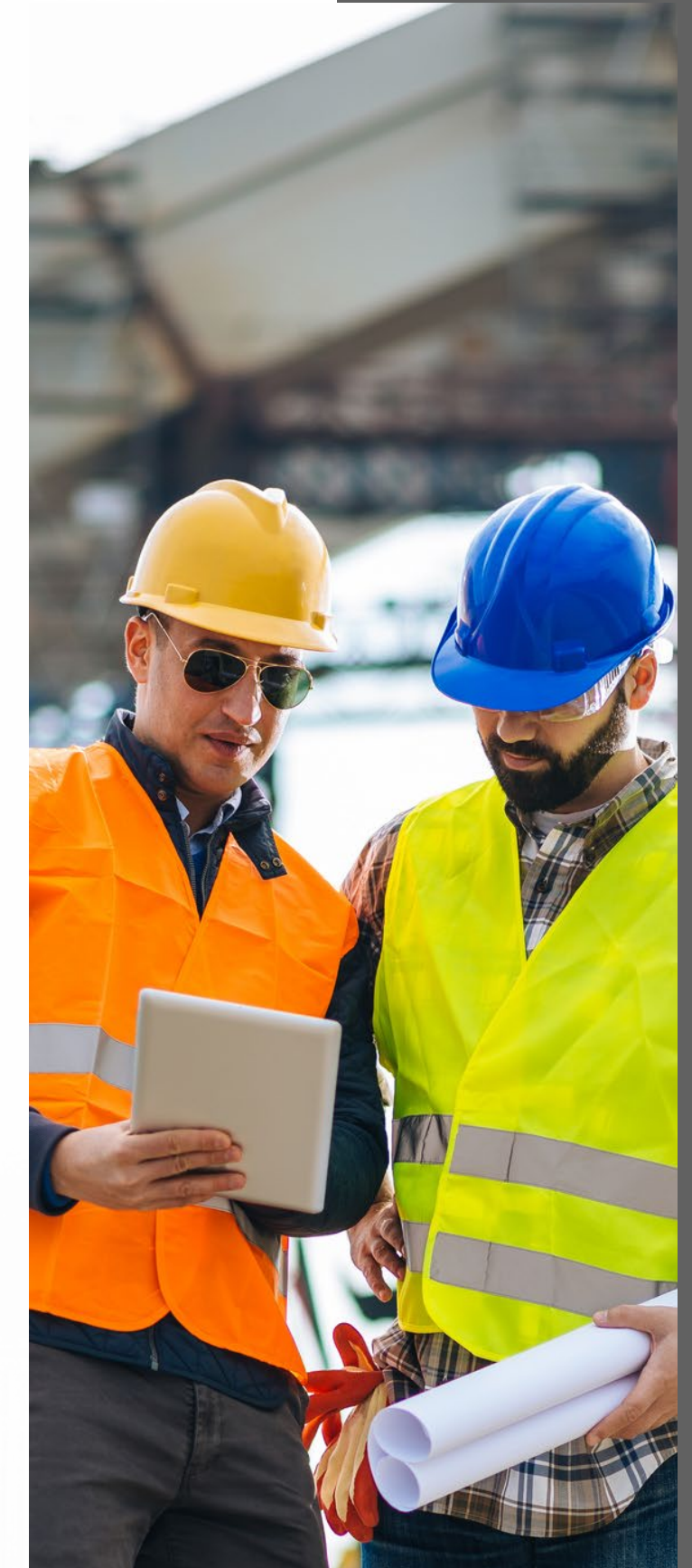

شركة دي سي بي السعودية



Date: 22nd November 2014

TO WHOM IT MAY CONCERN

This is to certify that **M/s Gulf Crete Ltd.** is our approved and certified applicator for all **DCP Saudi Company** Products for following ranges:

- Waterproofing system
- Joint Sealant
- Protective coating for concrete and masonry
- Epoxy Flooring
- Concrete repair
- Injection

This certificate is issued upon their request and without any liabilities on **DCP Saudi Company**, and valid for Six months from the date of issuance of this certificate.

Yours Sincerely,



For
DCP Saudi Co.

DCP Saudi
PO Box 60241 Riyadh 11576
Kingdom of Saudi Arabia
Tel. : +966 11 461 2003
Fax : +966 11 279 2009
Info.saudi@dcp-ltd.com
www.dcp-ltd.com



رأس المال المسجل ١٠٠٠٠٠٠ ريال سعودي، ص.ت: ٢١٧١٢٠٠ رقم القيد ٢١٧٠٧١ Licence: 217074 S.R CR. # 1010267930 Capital Paid: 1000000

CERTIFICATION



Constructive solutions

Ref : AY/06/22

Date: June 21, 2022.

TO WHOM IT MAY CONCERN

This is to certify that **M/s. Gulferrete** have considered as our certified and approved applicator for following Fosam Products' Range as below:

- Concrete Repair.
- Protective Coatings.
- Industrial Flooring.
- Joint Sealants.

This certificate is issued upon their request without any liabilities on Fosam Company Limited and valid for six months from the date of issuance of this certificate.

Yours sincerely,
For **Fosam Company Limited**



Fosam Company Limited
Head Office
PO Box 11081
Jeddah - 21453
Saudi Arabia
C.R. No. 31273
Paid up Capital: SR3,000,000
www.fosroc.com

رقم القيد: ٣١٢٧٣ - ص.ت: ٢١٤٥٣
+966 (٠٢) ٤٥٣ ١١٠٨١
+966 (٠٢) ٤٥٣ ١١٠٨١
fosam@fosroc.com

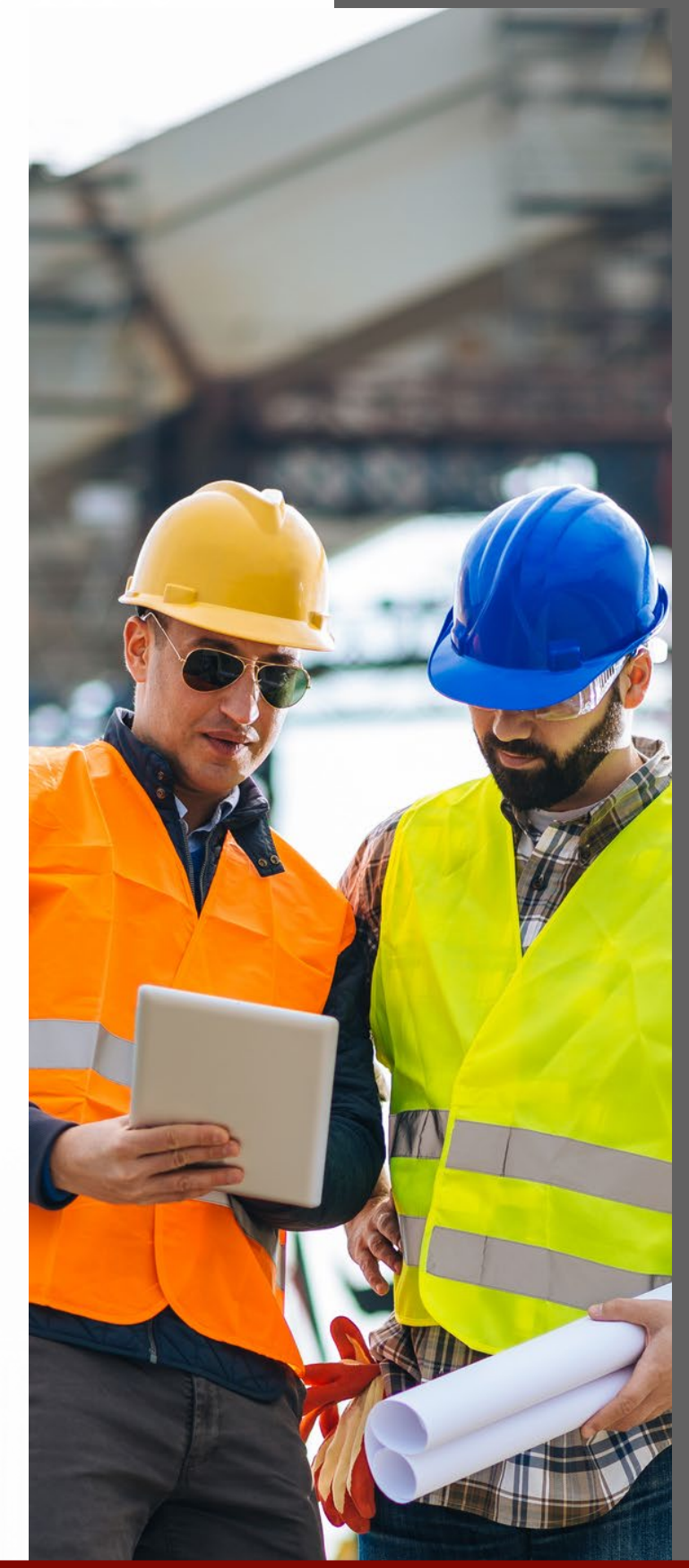



CERTIFICATION

شركة الصافي - دانون المحدودة
Al Safi - Danone Co. Ltd.

بسرنا في فرع المدينة المنورة ان نتقدم بالشكر الجزيل لشركة خليج الخرسانه المحدودة (للانشاءات والصيانه) فرع منطقة المدينة المنورة على ما قدموه من صيانة وتشطيبات للمستودعات الخاصه بالشركه بالاضافه الى الممرات والرمبات الخاصه بالشركه بالاضافه الى (75 متر) مستودع خارجي تم تشطيب ارضيته بنويه الاوكسي وايضا بالاضافه الى (5 متر) ابوكسي سكريت رامب تم تشطيبه وتجديده خارج العقد

وتم استلام المستودعات الاخرى من السيد (سرور بار خان) بصورة معنزة من ناحية الارضيات والممرات والرسم الارضي وتحديد المسارات في داخل المستودعات

ونتمنى لكم دوام التوفيق والعطاء
والسلام عليكم ورحمة الله وبركاته

مدير فرع المدينة المنورة

2017/11/07

عنوان: الرياض 11463
المنطقة: المنطقة الجنوبية
الهاتف: 3339 11463
فاكس: 3338 11 791
مركز عملي رقم: 111-11174 - رقم خطوية المرفق التجارية (11463)
United Industry Company - Paid Up Capital SAR 24,000,000
C.R.No.(101012248) - C.C.No.(102374)
www.alsafidanone.com

CERTIFICATION

RECEIVED
20 JUL 2017
HARAM CONTRACTING & TRADING CO.

HARAM CONTRACTING & TRADING CO.

PROJECT: Dr. Mohammed Alaghi Hospital
CONTRACTOR: Hahem Contracting Co.

DOCUMENTS SUBMITTAL

TRANSMISSION OF DRAWINGS, DOCUMENTS, SAMPLES, ETC.	DELIVERY	SUBMITTED FOR	CODE
To: EKFO "Construction Manager"	Counter	APPROVAL	1
For Contractor: ENG Signature: [Signature]	Harvest Messenger	INFORMATION	2
FOR CR USE ONLY:	Other	COORDINATION	3
Start Work Code: / / 75	Site: [] [] [] []	ACTION	CODE
Out to Client: / / 75	Out to Eng: / / 75	APPROVED	A
In from Client: / / 75	In from Eng: / / 75	APPROVED NOTED	B
Out to Contractor: / / 75		RESUBMIT	C
		DISAPPROVED	D
		FOR INFORMATION	E

REV.	QTY	DESP / SPEC REFERENCE	DESCRIPTION	Type	Code
1	1		CLINIC BUILDING GULF CRETE LTD CONTRACTING COMPANY Construction maintenance repair & restoration Pre-qualification of Gulf crete LTD • Cracks injector at B1 slab part A		B

For Your Kind Review & Approval.

Remarks:

- * Approved as a sub-Contractor for the purpose mentioned above.
- * All pre-cautions, provisions and methodology mentioned in the data sheet of the approved repair material must be followed during repair process.
- * A method of statement of the repair work to be submitted for approval prior to any commencement of work on site.

Reviewer's Signature: [Signature] CM Project Manager Date: 22/07/2017
Client Signature: [Signature] Date: 23/7/17

Type: Stop Drawing Sample Manufacturer's Data Certificate Business Other

Contractor's Signature: [Signature] Date: 23 July 17



Date and Time Information

Date & Time of Print: 09/08/2021 14:08:21 – Time Zone: Arabia Time

Organisation Details

Organisation Name (English input will be accepted only)	Gulf Crete Ltd
Trade Market Name (English input will be accepted only)	Construction, Maintenance
Address	Riyadh
Country	SAUDI ARABIA
Region	منطقة الرياض / Riyadh
ZIP/Postal Code	11323
Main Organisation Phone Number	0114655034
Organisation Fax Number	0112939553
Organisation Email Address	gulfcrete@outlook.com
Web site	www.gulfcrete.com

Organisation Legal Structure

Private Limited or Limited Liability Company (شركة ذات مسؤولية محدودة)

Company Registration Number	1010419075
VAT Number	301099174300003

User Details

Title	Mr.
First Name	
Last Name	
Telephone	0114655034
Mobile	+966599281826
Email	shahrukh@gulfcrete.com
Username	shahrukh@gulfcrete.com
Preferred Language	English (UK)
Time Zone	(GMT + 3:00) Kuwait, Riyadh, Doha, Manama

Contact List

Last Name	First Name	Email	Phone Number
1		shahrukh@gulfcrete.com	0114655034

Registration Date

30/06/2020

List of Forms

No Forms found

Path	Category Title	Last Modification Date	Status Summary	Assessments Present
1	Status Completed MAINTENANCE AND REPAIR FACILITY	11/01/2021	Assessment Status not visible	0
2	Status Completed ADHESIVE AND SEALANTS	11/01/2021	Assessment Status not visible	1
3	Status Completed INTERIOR FINISHING	11/01/2021	Assessment Status not visible	1
4	Status Completed OPERATION AND MAINTINANCE	11/01/2021	Assessment Status not visible	1
5	Status Completed FIRE FIGHTING SYSTEMS	11/01/2021	Assessment Status not visible	1
6	Status Completed CARGO HANDLING FACILITIES	11/01/2021	Assessment Status not visible	1
7	Status Completed TERMINAL	11/01/2021	Assessment Status not visible	1
8	Status Completed CAR PARKING	11/01/2021	Assessment Status not visible	1
9	Status Completed CIVIL WORKS	11/01/2021	Assessment Status not visible	1
10	Status Completed ROOFING MATERIALS	01/07/2020	Assessment Status not visible	1
11	Status Completed PAINTS & COATING SUPPLIES	01/07/2020	Assessment Status not visible	1
12	Status Completed METAL/STEEL STRUCTURE	01/07/2020	Assessment Status not visible	1

Path	Title	Date	Status Summary	Present
13	Status Completed AIRPORTS CONTRACTING	01/07/2020	Assessment Status not visible	1
14	Status Completed MAIN,MINOR SEWERAGE, NETWORK	11/01/2021	Assessment Status not visible	1
15	Status Completed CAR PARKING,OTHER SHADES STRCT	01/07/2020	Assessment Status not visible	1
16	Status Completed HANGERS,WAREHOUSE WORKS	01/07/2020	Assessment Status not visible	1
17	Status Completed MAIN ROADS,STREETS RELATED WRK	11/01/2021	Assessment Status not visible	1
18	Status Completed COOLANT AND ADDITIVES	01/07/2020	Assessment Status not visible	1
19	Status Completed ADHESIVE AND SEALANTS	01/07/2020	Assessment Status not visible	1
20	Status Completed INFRASTRUCTURE,BUILDING WORKS	01/07/2020	Assessment Status not visible	1
21	Status Completed GEOPHYSICAL	11/01/2021	Assessment Status not visible	1
22	Status Completed CAR PARKING SYSTEM	01/07/2020	Assessment Status not visible	1
23	Status Completed JOINTING,PACKING	11/01/2021	Assessment Status not visible	1
24	Status Completed VESSELS AND TANKS	01/07/2020	Assessment Status not visible	1
25	Status Completed DIGGING AND PILING WORKS	11/01/2021	Assessment Status not visible	1
26	Status Completed RESIDENT ENGINEERING SERVICES	11/01/2021	Assessment Status not visible	1
27	Status Completed MASONRY,STONE WORK TILE	01/07/2020	Assessment Status not visible	1
28	Status Completed MAINTENANCE SERVICES	11/01/2021	Assessment Status not visible	1
29	Status Completed MATERIALS	01/07/2020	Assessment Status not visible	1
30	Status Completed CLADDING WORKS	01/07/2020	Assessment Status not visible	1
31	Status Completed FORWARDING FACILITY	11/01/2021	Assessment Status not visible	1
32	Status Completed GENERAL WORKS	01/07/2020	Assessment Status not visible	1
33	Status Completed INDUSTRIAL WORKS	01/07/2020	Assessment Status not visible	1
34	Status Completed ROAD MARKINGS	01/07/2020	Assessment Status not visible	1
35	Status Completed EXTERIOR RENOVATION WORKS	11/01/2021	Assessment Status not visible	1
36	Status Completed INTERIOR RENOVATION WORKS	11/01/2021	Assessment Status not visible	1
37	Status Completed FIRE SUPPRESSION SYSTEMS	11/01/2021	Assessment Status not visible	1
38	Status Completed CARPET AND FLOORING	11/01/2021	Assessment Status not visible	1
39	Status Completed TOPOGRAPHIC & OTHER	11/01/2021	Assessment Status not visible	1
40	Status Completed PAINT	01/07/2020	Assessment Status not visible	0
41	Status Completed SEALANT	11/01/2021	Assessment Status not visible	0
42	Status Completed SEALER	11/01/2021	Assessment Status not visible	0
43	Status Completed SEAL	11/01/2021	Assessment Status not visible	0
44	Status Completed JOINT	11/01/2021	Assessment Status not visible	0
45	Status Completed INSULATION	01/07/2020	Assessment Status not visible	0

No Segmentation Assessment found

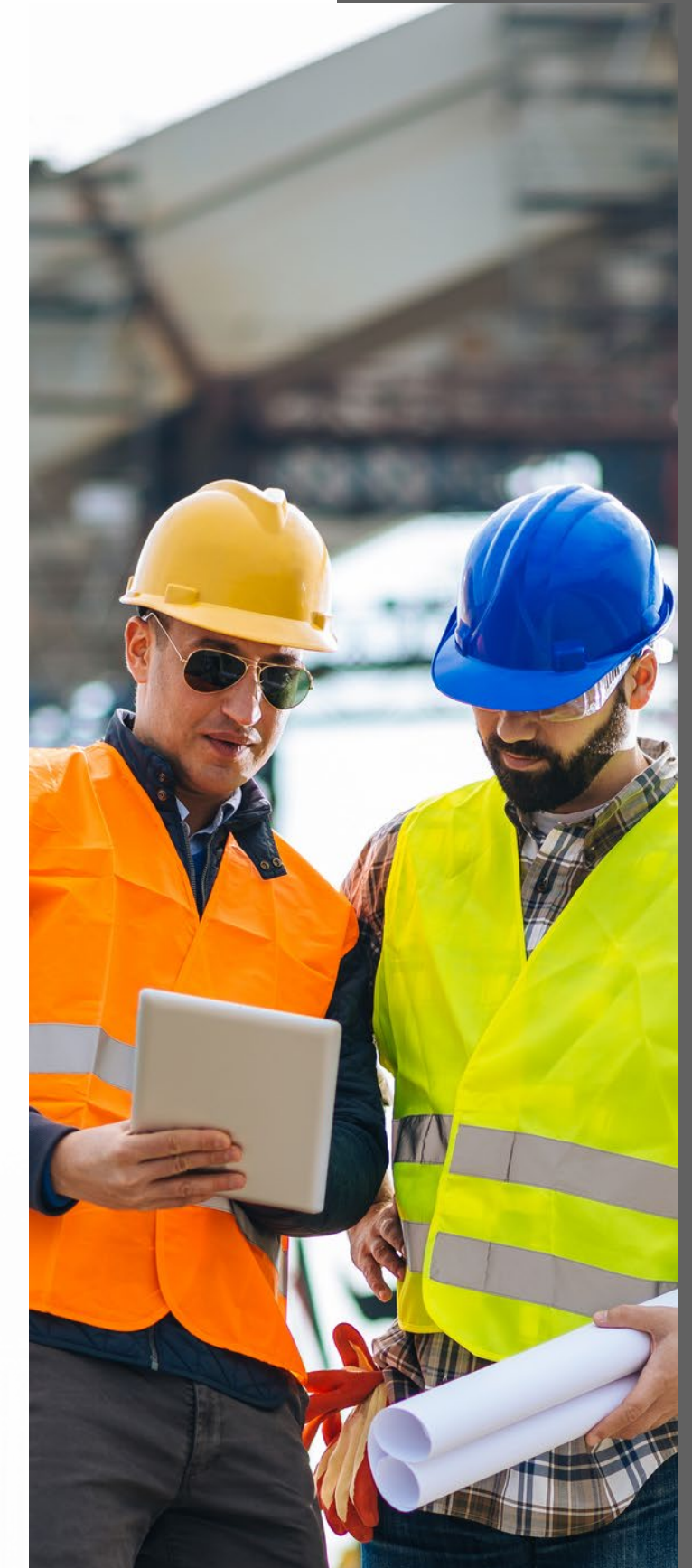

Approved: Updates to SWCC - Supplier registration questionnaire



Ariba Administrator <no-reply@smtp.mn2.ariba.com>

To ● ShahRukh Ali Hassan

 Click here to download pictures. To help protect your privacy, Outlook prevented automatic download of some pictures in this message.

SWCC

Hello ShahRukh Ali,

SWCC has approved the updates to SWCC - Supplier registration questionnaire that Alwaleed A. Al-Muhanna submitted on Wed, 04 Aug, 2021.





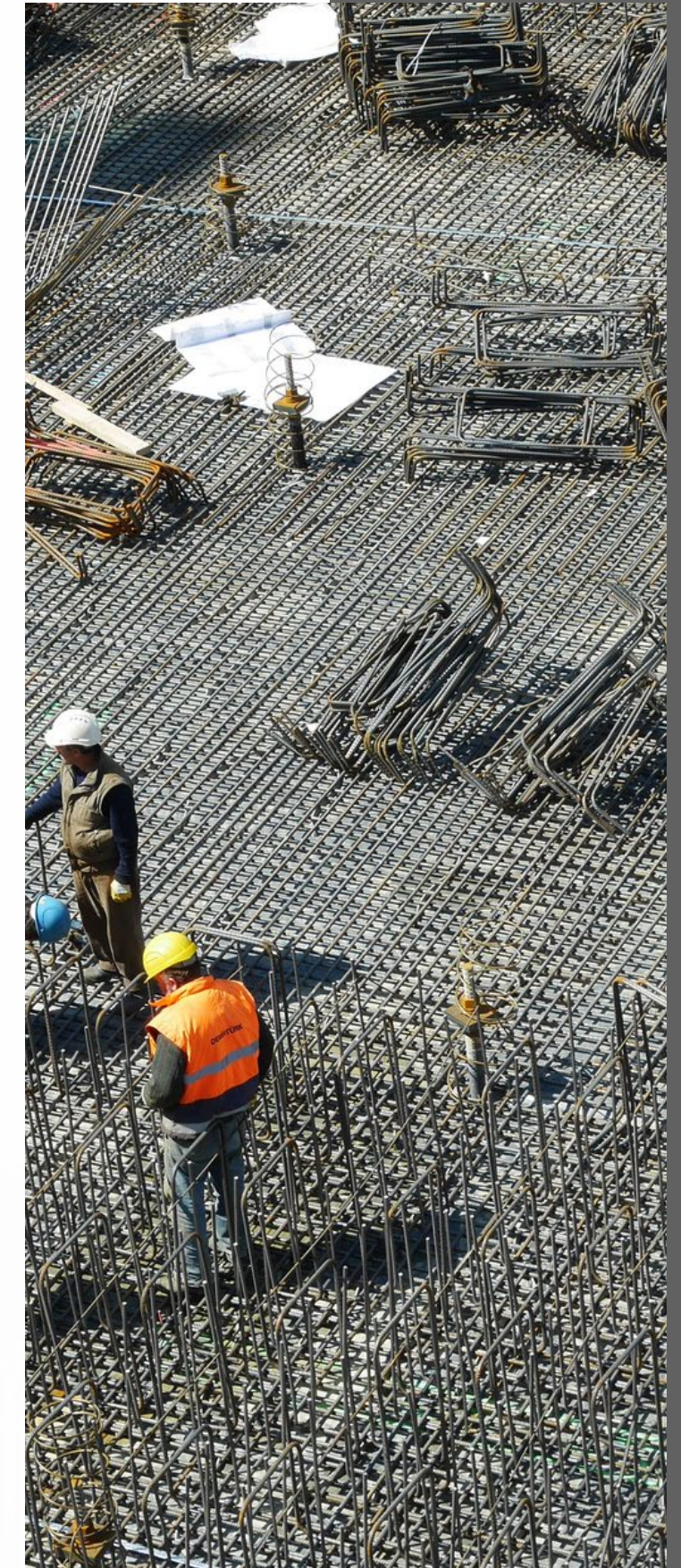

Best Regards,

SAP Ariba team

You are receiving this email because your customer, SWCC, has identified you as the appropriate contact for this correspondence. If you are not the correct contact, please contact SWCC.





							
Client: National Housing Company		PMC: Dar al-handasah		Consultant: Khatib & Alami		General Contractor: Tamimi Global Company Ltd.	
MATERIAL SUBMITTAL							
AR	ME	CV	LA	Submittal No.	M	S	Rev.
ST	FE	QS	OT	Date: 7/13/2020	2	2	1
To: Khatib & Alami				From: Tamimi Global Company Ltd.			
Specs./ BOQ / Drawings Reference				List of Enclosure			
Application for: Roof Insulation / waterproofing (Precast, Fursa, Buildings).				<input type="checkbox"/> Copy of Related Drawing <input type="checkbox"/> Specification Ref. as per project specification (Sec.075700). <input type="checkbox"/> BOQ Reference(s): MURCIA BOQ <input type="checkbox"/> Drawing Ref.:			
Specified Material				<input checked="" type="checkbox"/> Compliance Statement <input type="checkbox"/> Catalogue <input type="checkbox"/> Others (Specify) <input type="checkbox"/> Test Certificate			
Proposed Material				<input checked="" type="checkbox"/> Compliance Statement <input type="checkbox"/> Catalogue <input type="checkbox"/> Others (Specify) <input type="checkbox"/> Test Certificate			
Manufacturer / Local Supplier				<input checked="" type="checkbox"/> Compliance Statement <input type="checkbox"/> Catalogue <input type="checkbox"/> Others (Specify) <input type="checkbox"/> Test Certificate			
Reasons for Alternative (if any)				<input checked="" type="checkbox"/> Compliance Statement <input type="checkbox"/> Catalogue <input type="checkbox"/> Others (Specify) <input type="checkbox"/> Test Certificate			
Contractor's Remarks:				<input checked="" type="checkbox"/> Compliance Statement <input type="checkbox"/> Catalogue <input type="checkbox"/> Others (Specify) <input type="checkbox"/> Test Certificate			
Contractor Incoming Signature: 				Contractor Outgoing Signature: 			
Date: 16/12/20				Date: 16/12/20			
Consultant Comments:							
<p>• THE FOLLOWING MATERIAL HAVE BEEN APPROVED: POLYFOAM 20, POLYUREA, ALYAF.</p> <p>• CALCULATION OF U-VALUE ARE WITHIN SBC 602, AS PROVIDED BY CONTRACTOR.</p> <p>• MOCKUP SAMPLE WITH TEST TO BE DONE PRIOR ANY DELIVERY.</p> <p>• COMPLETE SECTIONS AND DETAILS TO BE SUBMITTED ASAP.</p> <p>• SUBJECT TO NEGATIVE VARIATION ORDER INLG TO REMOVAL OF SBS WATERPROOF MEMBRANE. NEGATIVE ORDER TO BE FINISHED PRIOR ANY INVOICING.</p>							
For K&A: Signature: 				Date: 16/12/20			
ACTION CODE: <input type="checkbox"/> A - Approved <input checked="" type="checkbox"/> B - Approved as noted <input type="checkbox"/> C - Resubmit as Noted <input type="checkbox"/> D - Disapproved <input type="checkbox"/> E - No action taken <input type="checkbox"/> F - Retained for Info.							

CERTIFICATION

KING ABDULLAH FINANCIAL DISTRICT 

DOCUMENT SUBMITTAL FORM

Contract No: DB16P111 Work Package: DB16P111
 Title: PRE-QUALIF GULF CRETE LTD.CONTRACT Submittal Number: DB16P111-DC-A-0088
 From: Saudi Binladin Group Rev.: 0
 To: Dar Al-Riyadh Date: 03/Dec/2014
 Attn: Dar Al-Riyadh Submittal Package: DOC No. of Copies: 3

DOCUMENT DETAILS

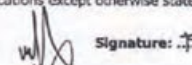

Category: Prequalification Specification: N/A
 Discipline: (A) ARCH BOQ Ref. No.: N/A
 Parcel No: 1.11 Building: 1.11 Drawing Ref.: N/A

We certify that the above submitted items have been reviewed in detail and are correct and in strict conformity with the contract drawings and specifications except otherwise stated.

For the Contractor
 Name: Syed Ahsan saeed Signature:  Date: 20/12/14
 Notes: PRE-QUALIFICATION FOR GULF CRETE LTD. CONTRACTING COMPANY_FIRE PAINT CO.LTD FOR PART-001

CONSULTANT'S COMMENTS
 1- Gulf Crete Ltd. Co. - complied w/ the Project Tech/ Specs.
 2- To ensure that the company (GCLCC) is Pre-Qualified and to be Approved by the Client.

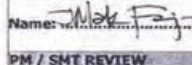
Approval Code
 Approved Approved As Noted Revise - Resubmit
 Rejected - Resubmit Receipt Acknowledged

Name:  Signature:  Date: 20/12/14
 Engineer Stamp: 

PM / SMT REVIEW
 Name: _____ Signature: _____ Date: _____

OWNER'S COMMENTS (Optional)
 Name: _____ Signature: _____ Date: _____

Approval shall not relieve the contractor of its obligations and liabilities under the Contract or constitute authorization of any change to Contract Documents, and therefore, shall not imply any recognition whatsoever of additional time or cost to the Contract.

Distribution
 Owner PM / SMT Engr/Constr Contractor

To Contractor
 Saudi Binladin Group
 Date: 21 DEC 2014
 RECEIVED DOCUMENT CONTROLLER DPK
 RECEIVED 03 DEC 2014
 PP-DC-08-FM Rev.1





TRAINING CERTIFICATION



hereby confirms the company



Construction, Maintenance & Restoration
للانشاءات و الصيانه

based in Riyadh, Saudi Arabia is a Certified Applicator of Waterproofing,
Repair, and Protection System,

that has successfully completed the theoretical and technical training to
apply the Penetron Crystalline Growth Waterproofing Systems:

**PENETRON, PENETRON ADMIX, PENEKRETE MORTAR, PENEPLUG,
PENEBAR, PENESEAL, & PENETRON INJECT**

This Certificate No. PEN/ME/CERT-020 is given on 28th NOVEMBER 2022
valid until 27th NOVEMBER 2023.

Sam Annous
Managing Director – GCC



Marinos Tseregounis
Technical Sales Director - Asia Pacific

PENETRON INTERNATIONAL MIDDLE EAST DMCC

German Arabian Serviced Offices DMCC-30th Floor, Office 006, Plot Y3, JLT, Dubai, U.A.E.
+971 54 466 4101 • penetron.com • sannous@penetron.com

These commodities, technology, or software were exported from the United States in accordance
with the Export Administration Regulations. Diversion contrary to U.S. law is prohibited.



hereby confirms the company



E.A. JUFFALI & BROTHERS CO.

based in Jeddah, Saudi Arabia is a Certified Distributor of Waterproofing,
Repair, and Protection System,

that has successfully completed the theoretical and technical training to
apply the Penetron Crystalline Growth Waterproofing Systems:

**PENETRON, PENETRON ADMIX, PENEKRETE MORTAR, PENEPLUG,
PENEBAR, PENESEAL, & PENETRON INJECT**

This Certificate No. PEN/ME/CERT-021 is given on 28th NOVEMBER 2022
valid until 27th NOVEMBER 2023.

Sam Annous
Managing Director – GCC



Marinos Tseregounis
Technical Sales Director - Asia Pacific

PENETRON INTERNATIONAL MIDDLE EAST DMCC

German Arabian Serviced Offices DMCC-30th Floor, Office 006, Plot Y3, JLT, Dubai, U.A.E.
+971 54 466 4101 • penetron.com • sannous@penetron.com

These commodities, technology, or software were exported from the United States in accordance
with the Export Administration Regulations. Diversion contrary to U.S. law is prohibited.

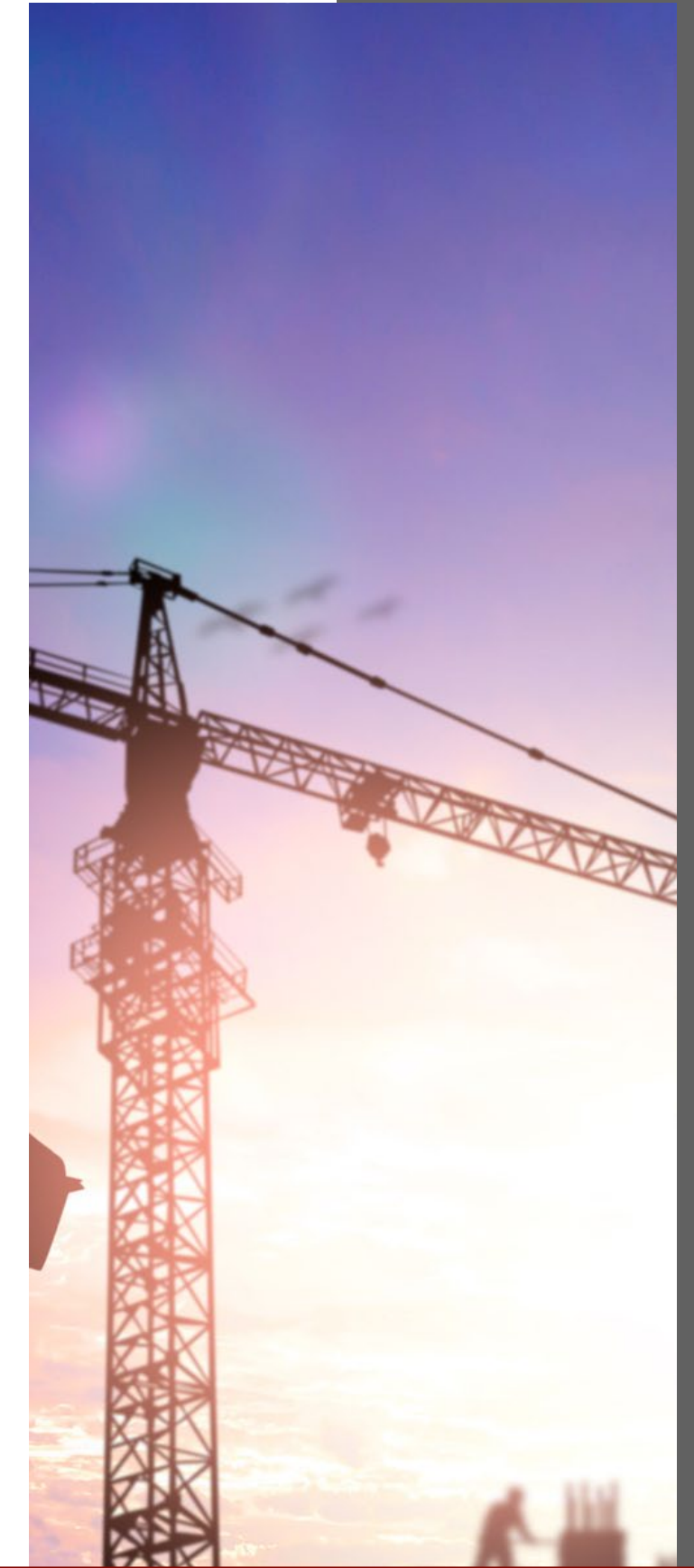

CERTIFICATE

FOR RECOMMENDED SIKA APPLICATORS

This is to certify that key people of the company
GULF CRETE CONTRACTING

successfully passed the applications training of the following Sika Products and is Recommended Sika Applicator:

SARNAFIL MECHANICALLY FASTENED & FULLY ADHERED SYSTEMS ,SIKAPLAN WATERPROOFING SYSTEM

This comprehensive training consisted of practical instructions about proper storage, preparation and application of Sika products.

The recommended applicator has been provided with the relevant Sika Product Data Sheets and all other technical documentation.

This confirmation is valid until the date of expiry below and may be renewed subject to the Recommended Applicator successfully completing any training courses required by Sika. The Recommended Applicator is responsible for ensuring full compliance by its employees with Sika's guidelines, training instructions and any other requirements of third parties.

Sika is not responsible for any loss or damage suffered by any third party as a result of any acts or omissions of the Recommended Applicator arising in anyway, including but not limited to breach of contract, misrepresentation, failure to comply with applicable laws or any other tort including negligence.

KSA, January 18, 2017

Expiry Date: 31 December 2017

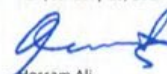

Hossam Ali
Technical & Specifications Manager KSA



Stevan Zivkovic
General Manager-Sika Saudi Arabia Co. Ltd

This Recommendation does not assume responsibility for the correct storage, mixing or use of these Products. Sika shall not be liable for damage to persons or property, loss of business or profit or any other direct, indirect, incidental, special or consequential damage or caused by the Recommended Applicator. Sika shall also not be responsible for use of these Products in a manner to infringe on any patent or other intellectual property rights held by others. Sika's liability is limited to the quality only of the supplied material. Any failures due to wrong application or storage not in accordance with the given guidelines as stated on the latest Technical Data Sheets, as well as structural or mechanical failures are excluded herein.



CERTIFICATE

FOR PROVISIONAL SIKA APPLICATORS

This is to certify that key people of the company

GULF CRETE CO.

successfully passed the applications training of the following Sika Products and is Provisional Sika Applicator:

**SIKACRETE,SIKAGROUT, SIKAFLOOR 263SL
SIKAFLOOR 264**

This comprehensive training consisted of practical instructions about proper storage, preparation and application of Sika products.

The Provisional applicator has been provided with the relevant Sika Product Data Sheets and all other technical documentation.

This confirmation is valid until the date of expiry below and may be renewed subject to the Provisional Applicator successfully completing any training courses required by Sika. The Provisional Applicator is responsible for ensuring full compliance by its employees with Sika's guidelines, training instructions and any other requirements of third parties.

Sika is not responsible for any loss or damage suffered by any third party as a result of any acts or omissions of the Provisional Applicator arising in anyway, including but not limited to breach of contract, misrepresentation, failure to comply with applicable laws or any other tort including negligence.

KSA, January 22, 2017

Expiry Date: December 31,2017

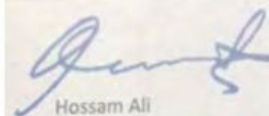

Hossam Ali
Technical & Specifications Manager KSA

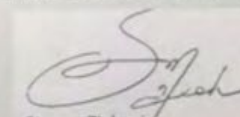

Stevan Zivkovic
General Manager-Sika Saudi Arabia Co. Ltd

This Recommendation does not assume responsibility for the correct storage, mixing or use of these Products. Sika shall not be liable for damage to persons or property, loss of business or profit or any other direct, indirect, incidental, special or consequential damage or caused by the PROVISIONAL Applicator. Sika shall also not be responsible for use of these Products in a manner to infringe on any patent or other intellectual property rights held by others. Sika's liability is limited to the quality only of the supplied material. Any failures due to wrong application or storage not in accordance with the given guidelines as stated on the latest Technical Data Sheets, as well as structural or mechanical failures are excluded herein.





CERTIFICATE

SIKA CARBODUR® S & SIKAWRAP® RANGE TRAINING ATTENDANCY

This is to certify that

**MR.ABDALLAH MOHD RASMI A ALKOUSA
OSMAN OMER OSMAN SALIH
AURANGZAIB SARWAR SARWAR YAR KHAN
AURANGZAIB SARWAR SARWAR YAR KHAN
MUHAMMAD JAMAL ZAIB AURANGZAIB SARWAR
JAWAID IQBAL KHAN
ASIF SHER AFSAR SHER**

Successfully passed the

INSTALLATION OF SIKA CARBODUR S AND SIKAWRAP RANGE

This comprehensive training consisted of presentations and workshops which included the following:

- Systems Description and components.
- Equipment Tools.
- Appliances & Components and general application guides
- On-site Checklist for Equipment and Materials

This training was conducted by Sika KSA LLC in May 9th 2017 Sika Saudi Arabia Co. Ltd.



CERTIFICATION



CERTIFICATE

FOR PROVISIONAL SIKA APPLICATORS

This is to certify that key people of the company

CONCRETE GULF LIMITED(GULF CRETE).

Successfully passed the applications training of the following Sika Products and is Provisional Sika Applicator:

SIKA CARBODUR® S & SIKAWRAP® RANGE

This comprehensive training consisted of practical instructions about proper storage, preparation and application of Sika products.

The Provisional applicator has been provided with the relevant Sika Product Data Sheets and all other technical documentation.

This confirmation is valid until the date of expiry below and may be renewed subject to the Provisional Applicator successfully completing any training courses required by Sika. The Provisional Applicator is responsible for ensuring full compliance by its employees with Sika's guidelines, training instructions and any other requirements of third parties.

Sika is not responsible for any loss or damage suffered by any third party as a result of any acts or omissions of the Provisional Applicator arising in anyway, including but not limited to breach of contract, misrepresentation, failure to comply with applicable laws or any other tort including negligence.

KSA, May, 2017

Expiry Date: December, 2017

Hossam Ali
Technical & Specifications Manager KSA

Stevan Zivkovic
General Manager-Sika Saudi Arabia Co. Ltd

This Recommendation does not assume responsibility for the correct storage, mixing or use of these Products. Sika shall not be liable for damage to persons or property, loss of business or profit or any other direct, indirect, incidental or consequential damage caused by the PROVISIONAL Applicator. Sika shall also not be responsible for use of these Products in a manner to infringe on any patent or other intellectual property rights held by others. Sika's liability is limited to the quality only of the supplied material. Any failures due to wrong application or storage risk in accordance with the given guidelines as stated on the Sika® Technical Data Sheets, as well as structural or mechanical failures are excluded herein.



CERTIFICATION





hereby confirms the company



Construction, Maintenance & Restoration
للانشاءات و الصيانه

based in Riyadh, Saudi Arabia is a Certified Applicator of Waterproofing,
Repair, and Protection System,

that has successfully completed the theoretical and technical training to
apply the Penetron Crystalline Growth Waterproofing Systems:

**PENETRON, PENETRON ADMIX, PENECRETE MORTAR, PENEPLUG,
PENEBAR, PENESEAL, & PENETRON INJECT**

This Certificate No. PEN/ME/CERT-020 is given on 28th NOVEMBER 2022
valid until 27th NOVEMBER 2023.

Sam Annous
Managing Director – GCC



Marinos Tseregounis
Technical Sales Director - Asia Pacific

PENETRON INTERNATIONAL MIDDLE EAST DMCC
German Arabian Serviced Offices DMCC-30th Floor, Office 006, Plot Y3, JLT, Dubai, U.A.E.
+971 54 466 4101 • penetron.com • sannous@penetron.com

These commodities, technology, or software were exported from the United States in accordance
with the Export Administration Regulations. Diversion contrary to U.S. law is prohibited.

www.rowadplastic.com



شركة الرواد الدولية للأغشية الصناعية المحدودة
Rowad International Geosynthetics Co. Ltd.

EFFECTIVE DATE: 01 January 2023

VALID UNTIL: 31 December 2023

AUTHORIZED INSTALLER & DISTRIBUTOR CERTIFICATE

To Whom It May Concern

Rowad International Geosynthetics Co. Ltd; is pleased to announce the appointment
of:

M/S Gulf Crete Ltd. Corporate
P.O.Box 285893 Riyadh 11323, Saudi Arabia
Email: morsy@gulfcrete.com

as an **Authorized Dealer and Specialist Installer** for supply and Installation of
Rowad Geosynthetic Liners such as:
HDPE Linings (Smooth and Textured)
LLDPE (Smooth and Textured)
And any other products that Rowad develop from time to time.

We are proud to be associated with **M/S Gulf Crete Ltd. Corporate** and wish
them every success in developing business avenues with the client.

Eng. Firas Ghazouani, MBA
Sales & Marketing Manager
Rowad International Geosynthetics Co. Ltd.



صندوق بريد 14164 الرياض 31424 المملكة العربية السعودية، ت: +966 13 812-1360 - ف: +966 13 812-1759، سجل تجاري: 2050071569 - عضوية: 137373

P.O. Box 14164 Dammam 31424 Saudi Arabia, T: +966 13 812-1360 - F: +966 13 812-1759, C.R.: 2050071569 - C.M.: 137373





شركة بي إي إس السعودية - مواد البناء المحدودة
 برج العثمان الطابق رقم 14
 طريق الملك سعود، الفرقة، الظهران 31322
 ب.ب 1884 الخبر 31952 - المملكة العربية السعودية
 Saudi BASF For Building Materials Co. Ltd.
 Al-Othman Business Tower 14th Floor
 King Saud Road, Al Qaslah, Dhehran 34232
 P.O. Box 1884, Al Khobar 31952

Date : 08th January, 2017
 Reference : JT/TSTA001-18:0001

CERTIFICATE OF ATTENDANCE

Subject : MasterSeal[®] 550SA Application Training Attendance Certificate

This is to certify that M/S Gulf Create had gone through a successful application training of MasterSeal[®] 550SA in Riyadh Metro Project in Riyadh by Saudi BASF.

The twelve (12) employees who attended the training and whose names appear below (Iqama copy attached) had shown good quality work. Hence they are provisional prequalified applicators to the Saudi BASF range of products as described above.

SN	Name of Attendee	Iqama / Passport Number
1	Azeem Ahammed	2418854200
2	Muhammed Shahzad	2391160047
3	Soharab Ali	2418854390
4	Muhammed Rizwam	2430976684
5	Sanawar Mahmood	2380790820
6	Jayed Muhammed	2413097334
7	Muhammed Shoaib	2402790295
8	Asif Sher	2290222997
9	Zulfiqar Khan	2304043744
10	Inamul Ziaul	2407937032
11	Naveed Rafiq	2414642914
12	Dipak Parasad	2424160105

This is valid for one year from date of issue and is subject to remain under constant monitoring for using Saudi BASF for Building Materials Co. Ltd. products. This certificate can be withdrawn, if the quality of the application is not to BASF's satisfaction.

For and on Behalf of
 Saudi BASF Co. Ltd.
Jignesh Thakkar
 Technical Manager



Head Office:
 Tel: +966 13 852 8600, 13 812 1140
 Fax: +966 13 832 8871, 13 812 1822
 www.master-builders-solutions.sa
 enquiry@saudibasf.com



الشركة ذات المسؤولية المحدودة في المملكة العربية السعودية ومن الصناعات المستحددة 99 مليون ريال مسجل تجاري رقم 1000000000
 المسجل طريق رقم 54 المنطقة الصناعية الثانية الامار المنطقة الصناعية السعودية هاتف: 13 812 1140 فاكس: 13 832 8871
 A private Company incorporated with limited liability in the KSA, Paid Up Share Capital SR 11 Million, Commercial Registration No. 2050037620
 Registered Office, Street No 58, Dammam 2nd Industrial Area, Saudi Arabia. Tel: +966 13 812 1231, Fax: +966 13 812 3269

CERTIFICATION

Firestone

Firestone Building Products AUTHORIZED CONTRACTOR

Firestone Building Products hereby confirms that the company

GULF CRETE LTD
 King Abdul Aziz Road – Al Murouj – Building 7060
 12282 Riyadh, Saudi Arabia

has successfully completed the Firestone Building Products Training Program. In addition, this company has installed numerous Firestone UltraPly TPO Roofing Systems.

As a result, this company is authorized to install the Firestone Building Products UltraPly TPO Roofing Systems, supervised by the Firestone Technical Department.

Done in Brussels, Belgium, March 2022

Expiry date: March 2023

Pascal Meirsschaert
 Technical Director
 Firestone Building Products





Assessment & Engineering DEP.



TABLE OF CONTENTS

CONDITION ASSESSMENT & INSPECTION SERVICES	04
NON-DESTRUCTIVE TESTING	05
BRIDGE LOAD TEST	06
BUILDINGS LOAD TEST	07
DURABILITY ANALYSIS	08
CONCRETE REPAIR	09
CATHODIC PROTECTION	10
STRUCTURAL STRENGTHENING	10
SOIL INVESTIGATION & REMEDIATION	11
3D ELECTRIC RESISTIVITY TOMOGRAPHY	12
ASSET MANAGEMENT SYSTEMS	13
STRUCTURAL WATERPROOFING-EXISTING STRUCTURES	14
STRUCTURAL WATERPROOFING-NEW CONSTRUCTION	15



CONDITION ASSESSMENT & INSPECTION SERVICES

Our
Services



The degradation of reinforced concrete material is a big challenge for owners who need to keep ageing structures in service and extend their life. RC condition assessment is a powerful decision-making process for engineers responsible for these types of structures. Exposure of these structures and reinforcing steel corrosion are well-known factors in the degradation of concrete civil engineering works, but it is difficult to quantify via conventional inspection methods (visual inspection and hammer sounding).



In fact, it is essential that during every condition assessment, a further step be taken towards understanding the in-depth anomalies in concrete and steel. Accordingly we state-of-the-art non-destructive testing Live instruments can be used to help conclude overall structural condition.



NON-DESTRUCTIVE TESTING



PROFOMETER

The all-in-one solution for rebar assessment and corrosion analysis.

Over view:

Advanced cover meter based on the new generation Profometer touchscreen with universal probe and scan cart. Enhanced correction factor for maximum cover accuracy on congested rebar arrangements. Dedicated functionalities for mapping concrete cover and for reporting one layer rebar arrangements.



PROFOMETER CORROSION

The most advanced corrosion instrument in the market.

Over view:

Advanced half-cell measuring instrument for on-site mapping of the corrosion potential. Dedicated software for assisted measurements with rod and wheel electrodes. Statistical software for immediate data interpretation.



PROCEQ GPR LIVE

The most innovative ultra-wideband portable GPR for concrete testing.

Over view:

The Proceq GPR Live portable ground penetrating radar instrument is the beginning of a new era in NDT. The outstanding, patented ultra-wideband technology combined with a compact wireless probe delivers unmatched industry performance. Just connect to your iPad and detect objects and back walls reliably, with a amazing clarity and ease of use.



PUNDIT LIVE ARRAY

PRO
making pulse echo testing simpler and faster with Artificial Intelligence (A.I.)

Over view:

The Pundit Live Array Pro is a breakthrough in on-site productivity and image clarity for concrete NDT. The rugged, compact, wireless transducer array incorporates cutting-edge multi-channel Ultrasonic Pulse Echo technology.



PUNDIT PL-200

The new Benchmark for Ultrasonic Pulse Velocity Testing

Over view:

The Pundit 200 is a best-in-class UPV test instrument with an extended range of measurement modes. Rugged touchscreen with intuitive user interface for best possible measuring and analysis of the measured data.



ORIGINAL SCHMIDT LIVE

The world's most advanced R-value concrete test hammer

Over view:

The Original Schmidt Live is a uniquely versatile hammer that can be used as stand-alone analog hammer, a stand-alone digital hammer, together with a Bluetooth printer and finally as the world's most advanced R-value concrete test hammer with the Schmidt Live app.



RESIPOD

The world's most accurate concrete surface resistivity meter
 Over view :
 A complete solution for measuring the electrical resistivity of concrete both in the laboratory under controlled conditions and on site. Standard fixed spacing surface Wenner probe with variable spacing and bulk resistivity accessories.

BRIDGE LOAD TEST

Bridge load testing is a common structural evaluation technique usually done to measure physical properties of the bridge including deflections, strains, etc (Static and Dynamic load testing)...or to module and give a rating for the structure (through our diagnostic load test). It is usually carried out at the structure's different life phases including construction, maintenance, and repair stages. Structural Testing System (STS) has been designed expressly for performing live-load tests on highway and

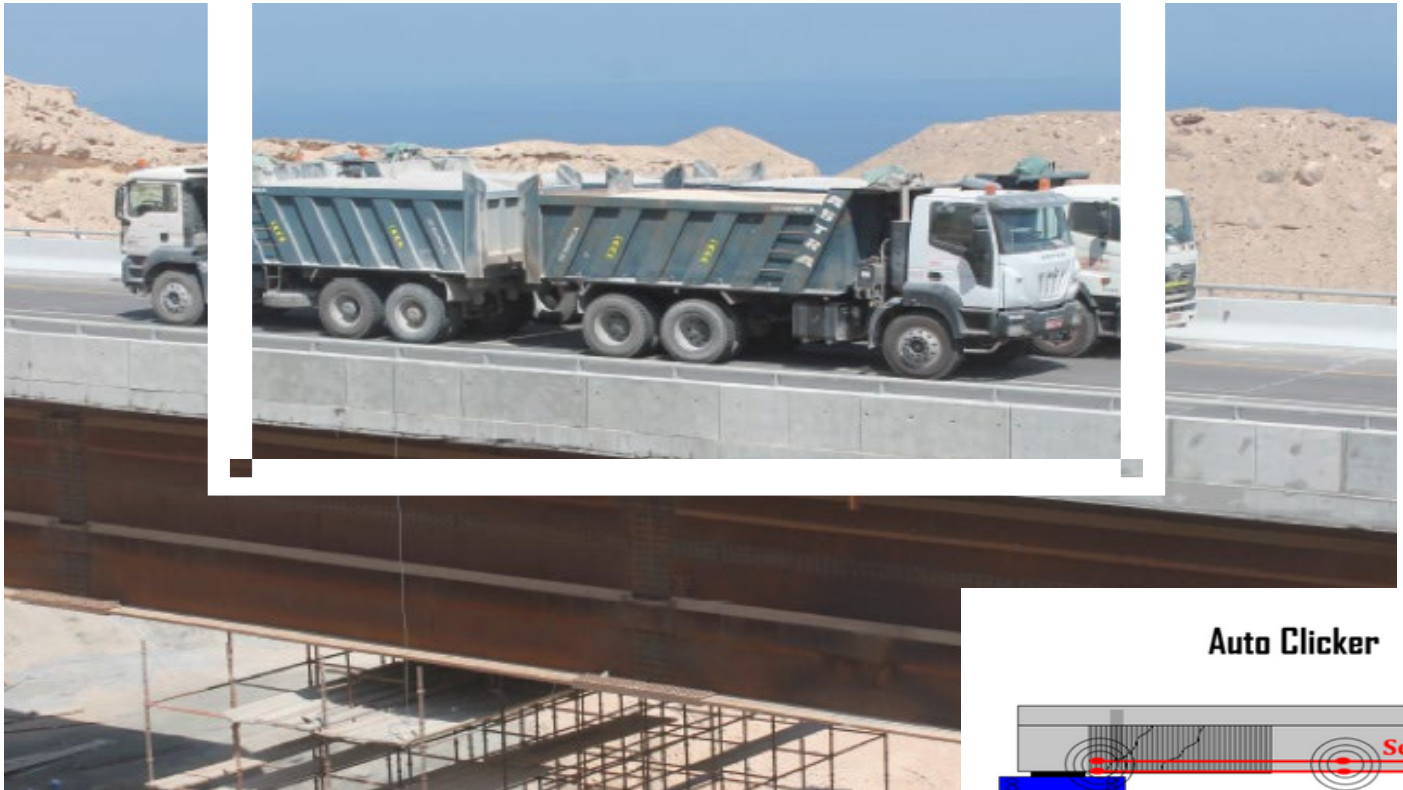

railway bridges, piers, and marine loading structures. Developed through the experience of testing more than 300 Structures worldwide (U.S., Asia, Australia, India & Saudi Arabia), the system has been turned to perfection making it one of the most efficient and reliable testing methods in the structural analysis field.

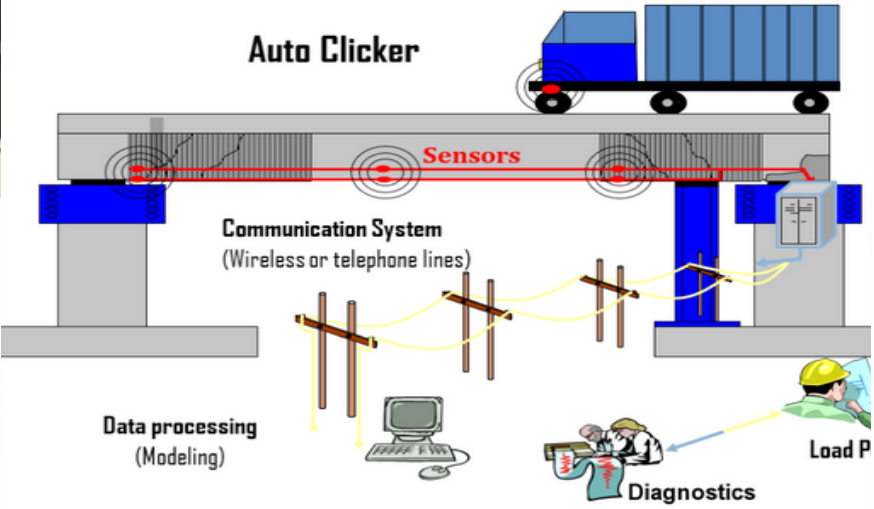



BUILDINGS LOAD TEST

Over view:
Load testing of building components or elements is a popular mean of demonstrating a structure's capabilities when a

Structural strength is unknown.

- Impractical change of use involving an increase in loading
- Bomb or fire damage.
- Materials defect or structural deterioration.

simple analysis is not practical. Typical situation that arise include: Our services are as follows:

- Suspicion in performance such as excessive creep deflection
- Required dimensions and material properties can't be measured or tested.



MEASUREMENTS

A set of response measurements shall be made after each load increment is applied and after the total load has been applied. On the structure for at least 24 hours. Real-time monitoring of deflections and strains is usually undertaken for building load tests using smart sensors installed on the structure to be tested. Those instruments are connected to a data acquisition system which collects.

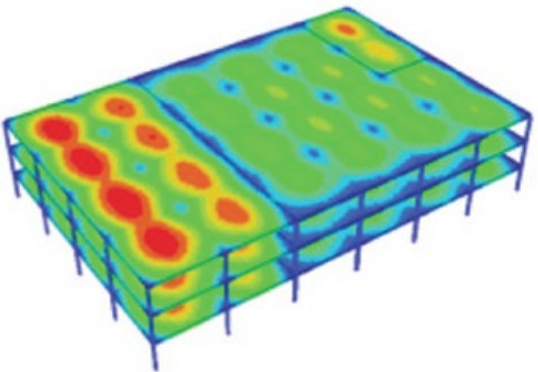



DURABILITY ANALYSIS

With years of experience, Co -mender's Team recognized that the durability of concrete structures is related not only to design and material but also to construction issues. Upon completion of new concrete structures, the achieved construction quality always shows a high scatter and variability, and in severe environments, any weaknesses in the concrete structures will soon be revealed in the final condition of the structure whatever specifications and constituent materials have been applied.



Our Services

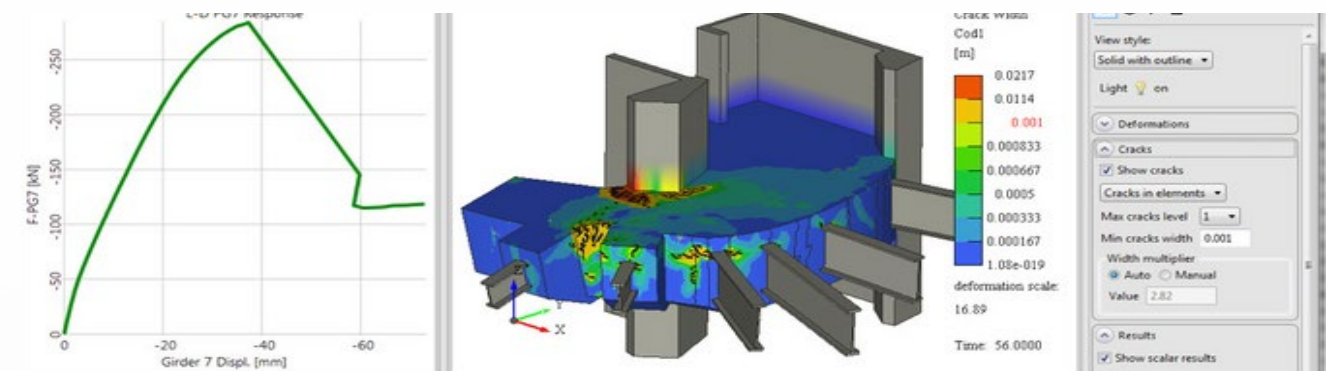
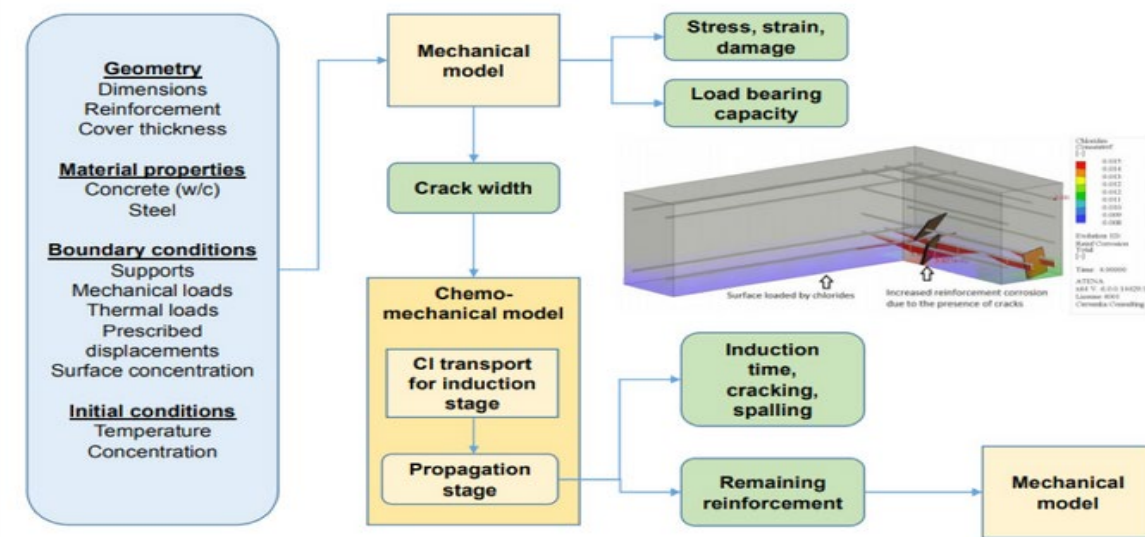

In order to better take all this variability into account and to evaluate durability analysis combined with structural analysis software should be applied.

our experts and in collaboration with its local engineers and with the aid of its communication technology can provide its customers with full comprehensive service for better concrete quality and better construction practices in new construction sites and to evaluate remaining life and residual strength in existing structures.





CONCRETE REPAIR

Our Services

Deterioration in concrete is a big challenge and a major concern for structures and utilities owners especially when it reaches an advanced stage and starts causing an increase in shutdown and replacement costs and create a safety hazard for occupants.

with the aid of its advanced technologies, utilizes state-of-the-art materials, repair methods, tools and trained engineers to repair and restore concrete surfaces and structures.





CATHODIC PROTECTION

Our Services



Cathodic protection reduces costs for future repair work construction in contrast to earlier, when cathodic protection and extends the life expectancy of concrete structure. was only used as a method of repair. In both cases, Cathodic Many reinforced concrete structures suffer from premature protection efficiently stops ongoing corrosion and thus degradation, most commonly caused by chlorides. Today, degradation of concrete structure. cathodic protection is used by many building owners as an The system is comprised mainly of anodes, power supply integrated part of the maintenance strategy for reinforced and control units. concrete structures. We provide a full comprehensive service and supply wide range of anodes and equipment for existing Therefore, many reinforced concrete structures are prepared and new structures as well as customized power supplies for installation of cathodic protection a ready during the and control units.

STRUCTURAL STRENGTHENING

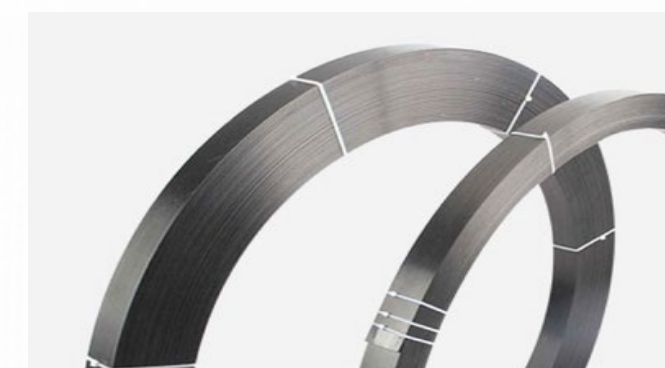
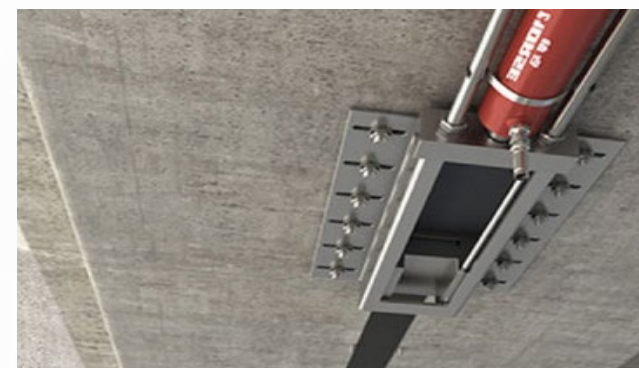

Many structures that originally were constructed for a specific use and loading level now are being renovated or upgraded for a different application that may require higher load-carrying capacity. As a result of these higher load demands, existing structures need to be reassessed and may

require strengthening to meet heavier load requirements. Business model is a perfect and highly efficient process that can provide our customers with a comprehensive solution including full Investigate – Design – Supply - Build capabilities.



SOIL INVESTIGATION & REMEDIATION

Our Services

Over the last 20 years, our team has acquired solid experience in soil specialized areas, such as investigations, geotechnical studies and the various engineering phases associated with Solutions development. In the past two years only, the company completed interesting soil investigation and solutions development

for major structures, such as bridges, power plants and buildings. In our approach we use Non-destructive techniques such as ERT (Electrical Resistivity Tomography) and GPR (Ground Penetrating Radar) to better understand the subsurface condition.



Our Services

- Soil and geotechnical investigation
- Design of shallow and deep foundations
- Soil improvement and stabilization techniques
- Vibrations monitoring

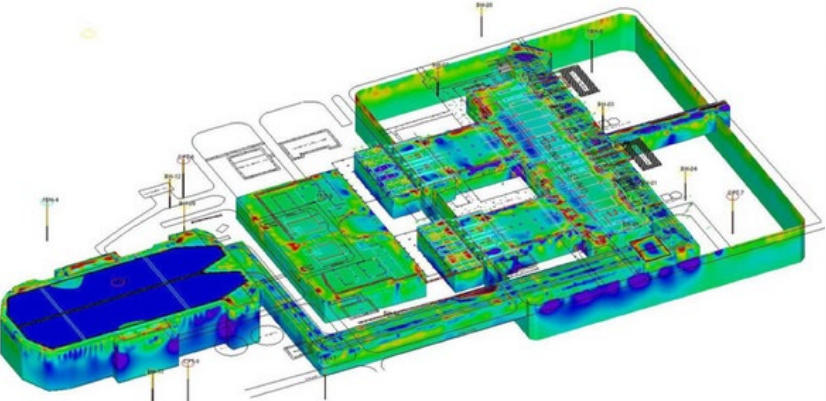



3D ELECTRIC RESISTIVITY TOMOGRAPHY

Our Services

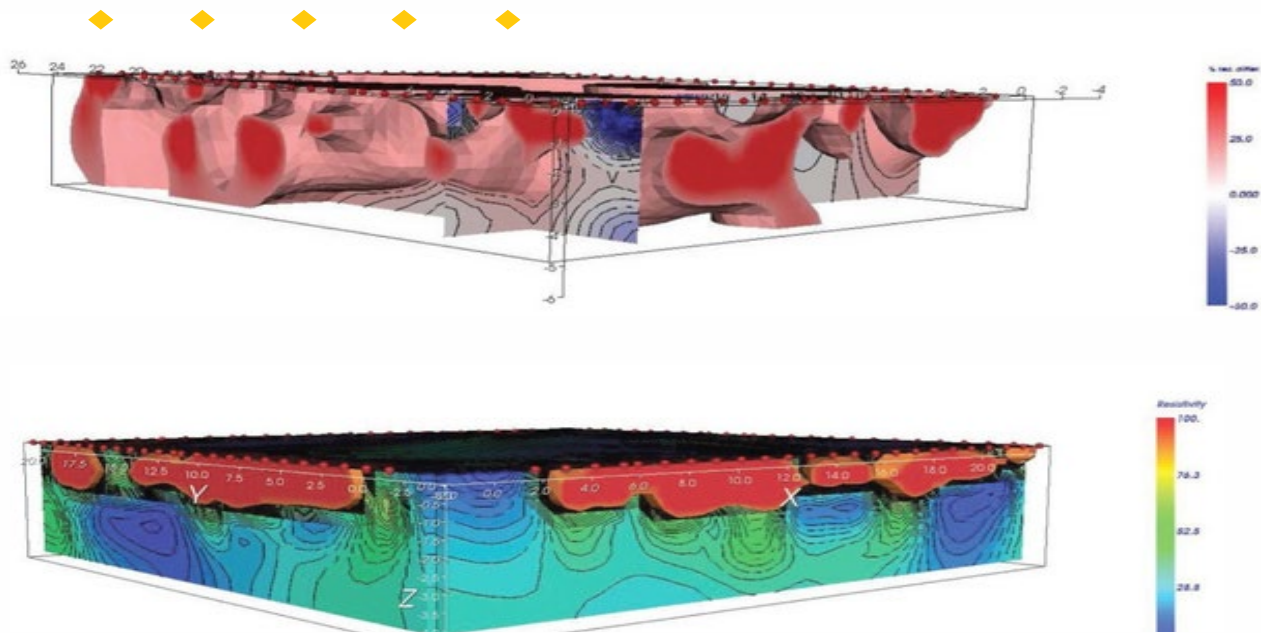

Characterization of subsurface soil and determination of soil strength are prerequisite for the foundation design of important civil engineering structures. Electrical characterization of soil is done by conducting surface electrical resistivity measurements and subsequently translating these data in terms of electrical properties of subsurface soil. Electric currents are injected into the ground and the resulting potential differences are measured at the surface, yielding information about the distribution of electrical resistivity below the surface. ERT involves repeated current injections through many electrode pair and into the region of interest (the ground) and the

recording of the potential distribution at all other electrodes for each current electrode pair. This procedure generates several electric potential images of the region of interest from different geometries of current injection. Analysis of these images is processed through a forward and an inverse algorithm. This combines all the data to yield 3-D resistivity distribution inside the studied region.

APPLICATIONS

- Determination the location of buried faults
- Detection of voids and cavities in the subsurface Leak
- Detection (water, fuel and others)
- Building Restoration Sites
- Real time monitoring of injection works



ASSET MANAGEMENT SYSTEMS

Our Services

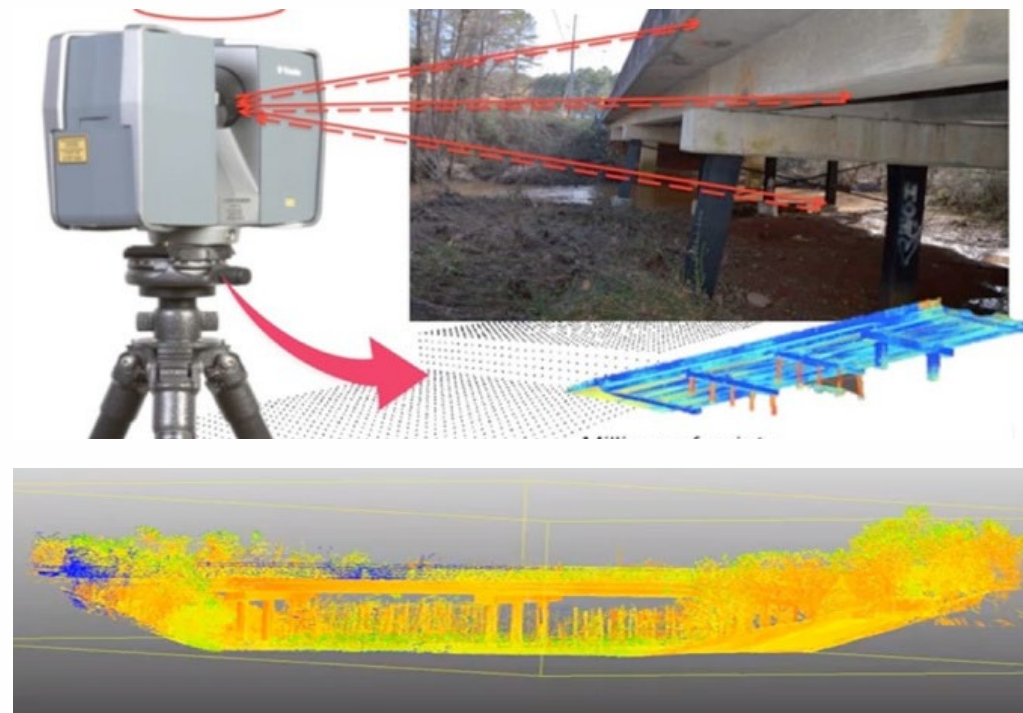

INVENTORY MODULE

We host your existing asset management data online. We perform Initial Inspection to update these data. We Laser scan some/all the structures and develop 3D models. We decompose the 3D model using BIM.

ANALYSIS MODULE

Our experts manage the structures. Analyze the collected data. Conduct Durability Analysis where needed. Prepare routine and detailed Inspection Schedule. Red flag critical structures. Use ComendX to Invite our local Inspectors to conduct the needed Inspection program.

Asset management is the process of making decisions on structure needs and arranging for resulting actions to occur at appropriate times. These may include maintenance, repair, rehabilitation, and replacement actions. Some routine maintenance actions are regularly scheduled, while other maintenance and repair actions are identified through the Department's Asset Inspection and Maintenance (AIM) system. Rehabilitation and replacement strategies are typically determined through an asset assessment that involves varying levels of analysis and engineering. All asset management decisions require inventory and inspection data on the structure to identify needs and appropriate actions. We and through our innovative business model, provides the owner's with the ability to manage their structures and making sure their inspection data are continuously updated without the need to hire a resident full time consulting firm. Our solution is comprised of four modules as follows:

INSPECTION MODULE

Our local Inspectors receive the Inspection Schedule and inspection checklists on our ComendX App. Conduct the needed inspection and/or NDT. Uses ComendAIR AR to assign detected defects into the developed 3D model for the critical structure. Depending on availability, our experts can participate online using ComendAIR or alternatively make a virtual tour in the inspected structure.

REPAIR MODULE

Our experts prepare the Inspection and testing results reports. Preparation of full repair strategy including B.O.Q. Inviting local partners to bid for the developed repair solution.



STRUCTURAL WATERPROOFING-EXISTING STRUCTURES

Water can leak into and out of structures. Reasons for this can be cracks, failed joints and even through permeable substrates. Once identified, if not treated, further problems can occur including the corrosion of reinforcement, thus resulting in durability issues and consequential loss of a usable area within the structure.

we collaborates with solutions providers and provides comprehensive solutions for all your basements water leakages and durability issues.

Our
Services

Our services are as follows:

- ◆ Full Condition assessment
- Durability Analysis
- Design of repair and waterproofing solutions
- Supply of materials and Technologies

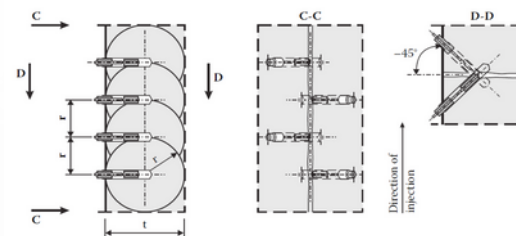

t: Crack depth
r: Effective radius of a single packer and distance of each packer (max. 60 cm)

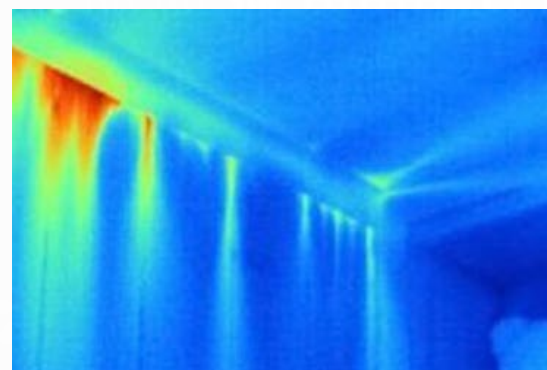



STRUCTURAL WATERPROOFING-NEW CONSTRUCTION

Our Services

ENGINEERING:

Engineering experts collaborate with designers and construction firms throughout all stages of design and construction and provides the following services:

- General advices on the design of underground structures.
- Design the additional post-tensioning system for vertical walls to reduce or eliminate cracking
- Revision and approval of concrete mix design
- Review the reinforcing bars detailing for shrinkage requirements.
- Review the design of the jointing system and introducing cracks inducers if needed
- Construction management including recording of data, photographs and plans for laying all our technologies systems.

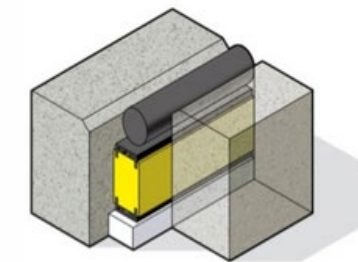
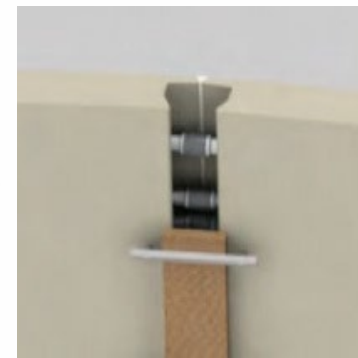
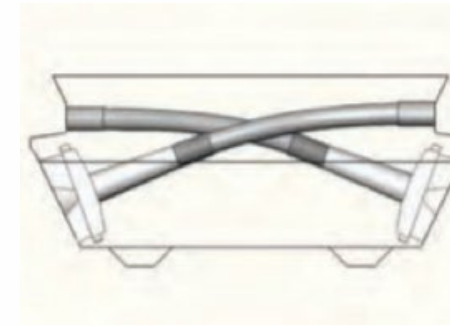

WATERPROOF CONCRETE

engineering team reviews the mix design, conducts trial mixes and advises our customers with the use of our crystalline waterproofing admixtures where needed.

Also, we provide, monitoring of the concrete temperature and maturity Experts Supervision of the concrete quality, both on-site during construction and testing in the laboratory using our Co-mendAIR technology.

POST-TENSIONING SYSTEM

and in collaboration with its partner OVM-MENA have developed a special post-tensioning system that can be applied to vertical walls and reduces the amount and width of cracking.

Similarly to post-tensioned water-tanks the cracks in basement walls can be better controlled or even eliminated providing better durability and functionality to the basement spaces.

WATERSTOP

Joints and penetrations are the most critical elements in the below grade waterproofing system.

Special attention is needed in the design phase and construction phase to achieve a sealed joints. Co-mender's joints sealing system is carefully selected for both durability and performance.

TECHNOLOGY

After designing the full waterproofing system and reviewing all its essential components, Co-mender provides its international waterproofing experts live and easy access to the site operations during concrete placement .

It's smart monitoring system and live connectivity with the site team allow the experts to provide their technical advice right on the spot eliminating a lot of possible concrete quality issues at site.

Augmented Reality -AR

AR is set to 'fundamentally change' industrial jobs in the next five years



Smart Helmet





GULF CRETE LTD.

شركة خليج الخرسانه المحدوده

CONTACT US



+966 114 655 034



Gulfcrete.com



Info@Gulfcrete.com

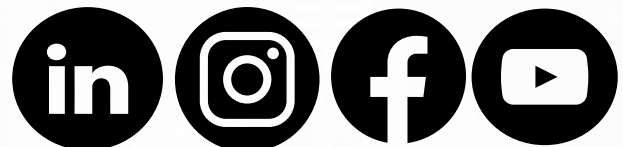

GULFCRETE



SCAN ME

THANK YOU

WWW.GULFCRETE.COM

